

# *Have Mercy*

## **Building instructions**

**v2.2**

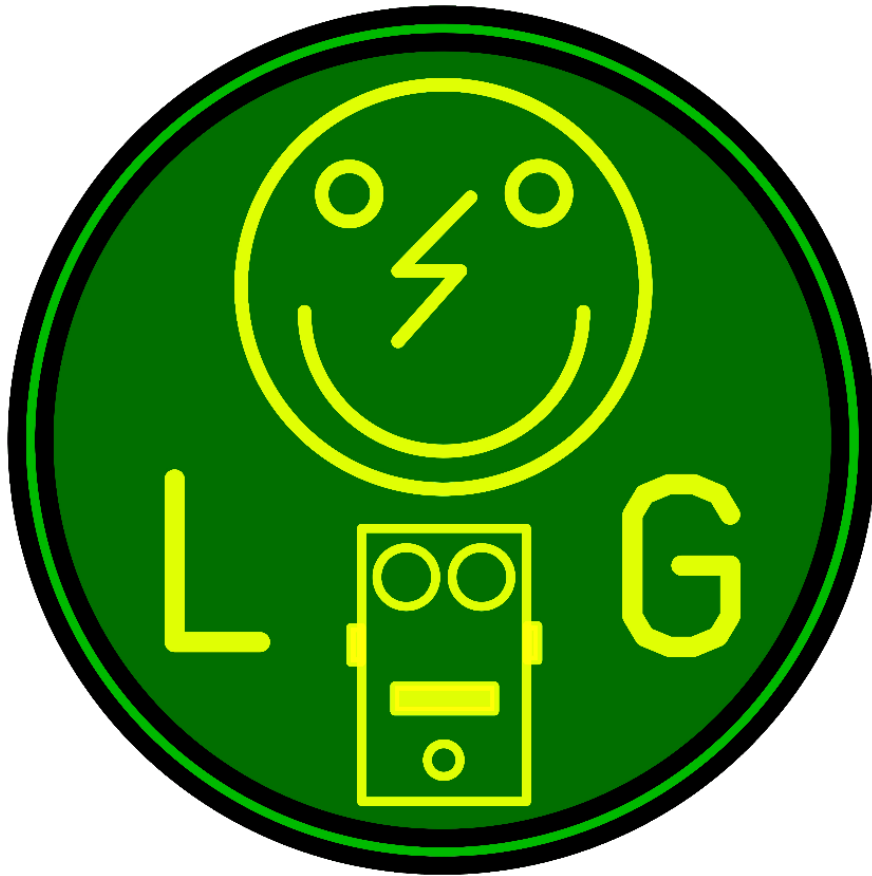

# Table of contents

Main PCB layout .....	3
Components Main PCB.....	4
Footswitch PCB.....	5
Build sequence .....	6
Calibrating to stock factory settings.....	7
Switch settings.....	7
Off board wiring .....	8
Incorporating the expression pedal .....	9
Modifications.....	10
Transistors .....	10
Op amp and charge pump.....	10
Pot values .....	10
Hissing and squealing .....	10
Troubleshooting .....	11
Schematic .....	12

**Read this entire manual thoroughly before you start building the effect! There are some available options and you should choose which one you want to incorporate before starting your build.**

Last update: 17-11-2024



# Main PCB layout

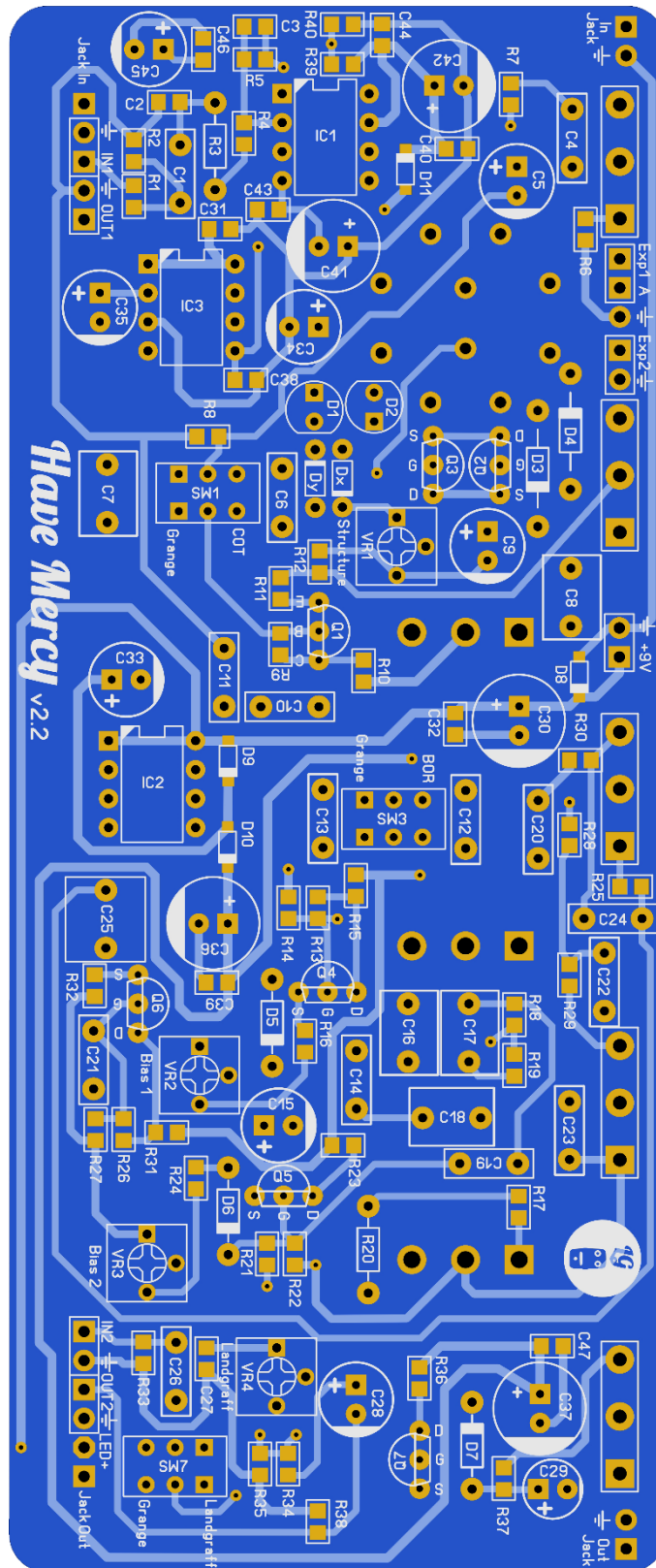

Dimensions: 52,5 mm x 130 mm  
2.1 inch x 5.15 inch

Manufacturers and product names are mentioned solely for circuit identification, and where applicable their trademarks are the property of their respective owners who are in no way associated or affiliated with the author. No cooperation or endorsement is implied.



## Components Main PCB

Part	Value	Comment	Part	Value	Comment
C1	<a href="#">10n</a>	SMF/MKT/FKP2	D1	<a href="#">LED 5mm red</a>	
C4	<a href="#">10n</a>	SMF/MKT/FKP2	D2	<a href="#">LED 5mm red</a>	
C5	<a href="#">33u</a>	Electrolytic 25V+	D3	1N270	Germanium Diode
C6	<a href="#">56n</a>	SMF/MKT/FKP2	D4	1N270	Germanium Diode
C7	<a href="#">470n</a>	SMF/MKT/FKP2	D5	<a href="#">Zener 9.1V</a>	
C8	<a href="#">470n</a>	SMF/MKT/FKP2	D6	<a href="#">Zener 9.1V</a>	
C9	<a href="#">47u</a>	Electrolytic 25V+	D7	<a href="#">Zener 10V</a>	
C10	<a href="#">100n</a>	SMF/MKT/FKP2	Dx	<a href="#">1N4148</a>	<b>OPTIONAL</b>
C11	<a href="#">47n</a>	SMF/MKT/FKP2	Dy	<a href="#">1N4148</a>	<b>OPTIONAL</b>
C12	<a href="#">100n</a>	SMF/MKT/FKP2	IC1	OPA134	Original OPA132 (SOIC-8)
C13	<a href="#">22n</a>	SMF/MKT/FKP2	IC2	<a href="#">LT1054</a>	
C14	<a href="#">22n</a>	SMF/MKT/FKP2	IC3	ICL7660S	Alternative LT1054
C15	<a href="#">22u</a>	<b>OPTIONAL</b>	P1	<a href="#">B25k</a>	Gain
C16	<a href="#">470p</a>	SMF/MKT/FKP2	P2	<a href="#">B1k</a>	Channel Blend
C17	<a href="#">150p</a>	SMF/MKT/FKP2	P3	<a href="#">B100k</a>	Tone
C18	<a href="#">220p</a>	SMF/MKT/FKP2	P4	<a href="#">A100k</a>	Volume
C19	<a href="#">22n</a>	SMF/MKT/FKP2	P5	<a href="#">C20k</a>	Boost
C20	<a href="#">22n</a>	SMF/MKT/FKP2	Q1	<a href="#">2N5088</a>	
C21	<a href="#">22n</a>	SMF/MKT/FKP2	Q2	<a href="#">2N7000</a>	
C22	<a href="#">2n2</a>	SMF/MKT/FKP2	Q3	<a href="#">2N7000</a>	
C23	<a href="#">2n2</a>	SMF/MKT/FKP2	Q4	BS170p	<a href="#">BS170 has reversed pinout</a>
C24	<a href="#">10n</a>	SMF/MKT/FKP2	Q5	BS170p	<a href="#">BS170 has reversed pinout</a>
C25	<a href="#">1u</a>	SMF/MKT/FKP2	Q6	BS170p	<a href="#">BS170 has reversed pinout</a>
C26	<a href="#">100n</a>	SMF/MKT/FKP2	Q7	BS170p	<a href="#">BS170 has reversed pinout</a>
C28	<a href="#">10u</a>	Electrolytic 25V+	R3	8M2	1% metalfilm MF0207
C29	<a href="#">4u7</a>	Electrolytic 25V+	R20	100R	1% metalfilm MF0207
C30	<a href="#">100u</a>	Electrolytic 25V+	SW1	DPDT	Cap (MSS22D18*)
C33	<a href="#">10u</a>	Electrolytic 25V+	SW2	<a href="#">2P4T Rotary</a>	Structure
C34	<a href="#">33u</a>	Electrolytic 25V+	SW3	DPDT	Cap 2 (MSS22D18*)
C35	<a href="#">10u</a>	Electrolytic 25V+	SW4	<a href="#">SP3T</a>	Gain (On-Off-On)
C36	<a href="#">100u</a>	Electrolytic 25V+	SW5	<a href="#">SP3T</a>	Presence (On-Off-On)
C37	<a href="#">100u</a>	Electrolytic 25V+	SW6	<a href="#">SPDT</a>	Variac (On-On)
C41	<a href="#">100u</a>	Electrolytic 25V+	SW7	DPDT	Landgraff bypass (MSS22D18*)
C42	<a href="#">100u</a>	Electrolytic 25V+	VR1	<a href="#">B1k</a>	Gain Structure
C45	<a href="#">33u</a>	Electrolytic 25V+	VR2	<a href="#">B10k</a>	Bias 1
Jack In		<a href="#">Stereo Jack</a>	VR3	<a href="#">B500R</a>	Bias 2
Jack Out		<a href="#">Mono Jack</a>	VR4	<a href="#">B10k</a>	Landgraff
DC		<a href="#">DC jack</a>			

All parts need to be 25V+ rated

**A=Log, B=Lin, C=Rev. Log**

\* Available on Aliexpress



## Footswitch PCB

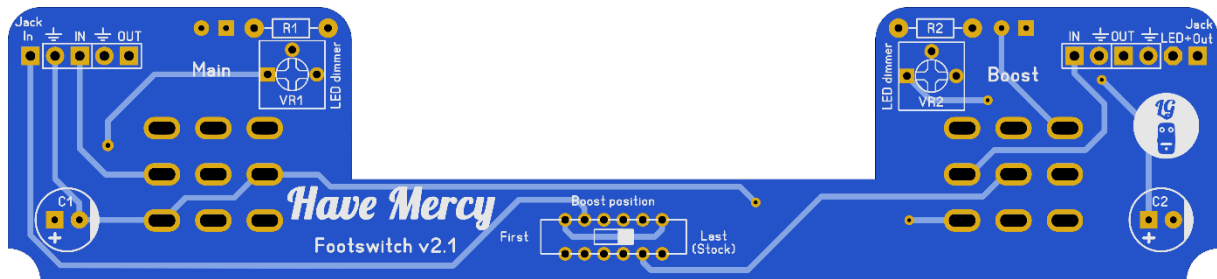

Part	Value	Comment	Part	Value	Comment
R1	<a href="#">390R</a>	MF0207	SW1	<a href="#">3PDT</a>	
R2	<a href="#">390R</a>	MF0207	SW2	<a href="#">3PDT</a>	
VR1		LED dependent	SW3	4PDT	Akeys MSS-42D01 (Aliexpress)
VR2		LED dependent	C1	<a href="#">22u</a>	Electrolytic 25V+
D1	See below	<a href="#">LED flange</a>	C2	<a href="#">22u</a>	Electrolytic 25V+
D2	See below	<a href="#">LED flange</a>			

R1, R2, C1, C2, SW3, VR1 and VR2 should be soldered to the topside. SW1, SW2, D1 and D2 should be soldered on the bottom side. When using larger sized capacitors for C1 and C2 you might consider soldering them to the bottom side.

VR1 and VR2 vary depending on the LED you want to use for D1 and D2. For (ultra) bright clear 3mm LED's you can use these values and links to Tayda parts for D1/D2 and VR1/VR2:

Red : [B10k](#) (set at 6k8)  
 Blue : [B20k](#) (set at 15k)  
 Orange : [B5k](#) (set at 1k8)  
 Pink : [B20k](#) (set at 9k1)  
 White : [B50k](#) (set at 18k)  
 Green : [B100k](#) (set at 42k)

The original has 2 white LED's, but I personally prefer Red (D1) and Orange (D2).  
 The brighter you turn the LED the shorter its lifespan!

You will also need some [AWG22 or AWG24](#) hookup wire, some shrink tubing and a 1590XX enclosure.



## Build sequence

Soldering this board can be very complicated for some people since the solder pads are very close together. Use a magnifying glass to make the job easier.

The trick to soldering a PCB is to work from small to big components. My building sequence suggestions in this section are based on the parts I used myself. Sometimes some components are smaller (or bigger) so always use your own common sense and change the order accordingly. Usually capacitors differ a lot in size depending on their rating and value.

**Note:** Do not blow on your solder in an attempt to cool it down. That can result in a bad join that might corrode! Also take extra care not to short components.

Before you start soldering, read the modifications section and decide which mod you want to incorporate. You must read the part about incorporating the expression pedal else you might get into trouble at the end of your build!

Start by soldering the resistors and jumpers (if needed). When needed you can create a jumper using a spare piece of lead from a resistor, diode or capacitor. Next come the diodes (not the LEDs).

If you want to experiment with other transistors then you could socket them instead of soldering them to the board. You'll need a some 20 SIL sockets, break off the sockets and solder them to the board. Now is the time to solder these sockets on the PCB as well as the socket for the IC. Do not place the socketed transistors and IC until you are finished with all soldering and off board wiring!

Now continue by soldering the internal trimpots (**VR**) then solder the SMF and MKT capacitors. Now finish with soldering the transistors (if not socketed), LEDs and the Electrolytics.

If you are not using the drill templates, I suggest you now drill the holes in your enclosure so you can use it during the off board wiring.

**Note:** Really take some time to determine where to place the pots, switches, jacks and PCB in the enclosure before you start drilling. Measure twice, drill once. There is a [Tayda drill template](#) if you want to use a predrilled enclosure.

The component side of the PCB is the Top side. The pots and switches need to be soldered on the bottom side of the PCB (PCB mounted pots). The rectangle pad on the PCB indicates pin 1 of the pot. You can break off the pin I marked with the yellow circle using a small pair of pliers.

If you are planning on incorporating the **expression pedal**, you will need an extra jack as mentioned in that section.



## Calibrating to stock factory settings

Once everything is connected, you should calibrate **VR1 – VR4** to give you your optimum gain.

**VR1 (Gain Structure) : 100%** (full clockwise/right)

**VR2 (Bias 1) : 50%** (12 o'clock/middle)

**VR3 (Bias 2) : 100%** (full clockwise/right)

**VR4 (Landgraff) : 100%** (full clockwise/right)

These are the stock factory setting for the original pedal.

**VR1** will subtract some gain when lowered on the COT part of the pedal. **VR2** can add or subtract some gain on the 1<sup>st</sup> stage and **VR3** will subtract some gain of the 2<sup>nd</sup> stage when lowered.

**VR4** is a sort of pre gain for the boost part as used in the original Landgraff design. This will only have effect if you set **SW7** to Landgraff.

This is a very loud effect and prone to squeal at high gain. If that happens, adjust the settings of especially **VR1-VR3** as you desire to tame the beast. If you think you are lost in the calibration, just return the settings to the default settings and start over. You can also leave the settings at stock and choose to raise **R20** to 150R or 220R.

## Switch settings

	Structure
<b>1 (full counter clockwise)</b>	None
<b>2</b>	LEDs
<b>3</b>	Mosfet
<b>4 (full clockwise)</b>	Germanium

	Gain	Variac	Presence
<b>Top</b>	High	Off	High
<b>Middle</b>	Low		Low
<b>Bottom</b>	Middle	On	Middle

Here is an example of what the enclosure could look like:





## Off board wiring

Off board wiring is very easy using the special designed Footswitch PCB. It fits a 9V battery however be warned that a depleting battery will not be able to deliver the 9V needed for the voltage doubler to work and produce 18V. I would recommend to use a good 9V adapter instead.

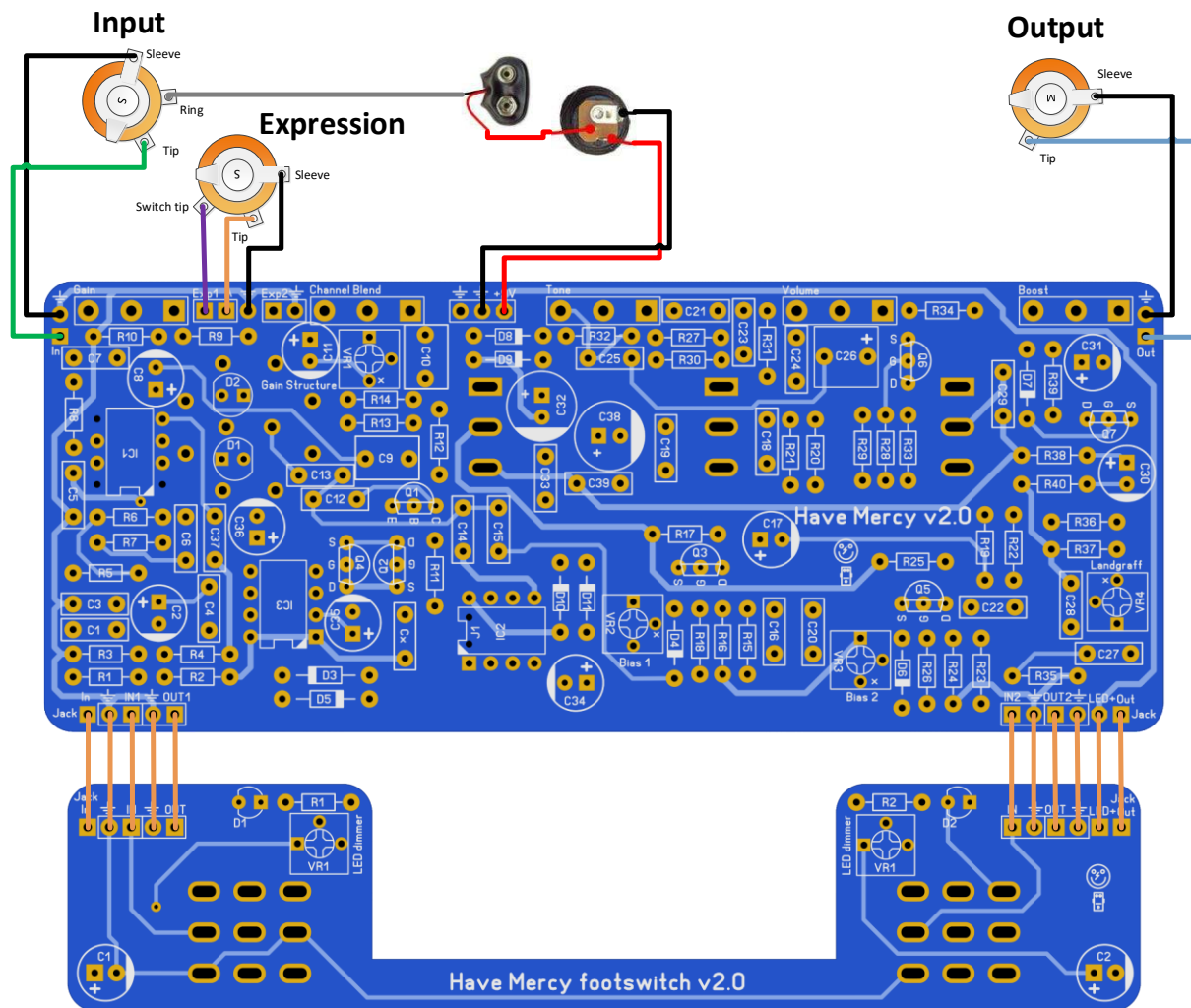



## Incorporating the expression pedal

There are 2 ways to incorporate an expression pedal. The first being as mentioned in the original pedal. The original adds a expression pedal parallel to the gain pot in the pedal. This results in around 12.5k ( $25k // 25k // 2M2 = \text{approx. } 12.5k$ ) and so makes the gain act a bit different.

To wire this configuration you should jumper **Exp1** and **A** and add a mono jack to Exp2 and ground like this:

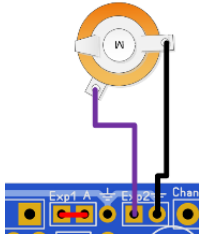

The other way is to replace the internal gain pot when inserting the expression pedal. This gives you more usable gain options when using different resistor values as it will use the full extent of the pot taper. This can be wired like this with a [switchable](#) jack:

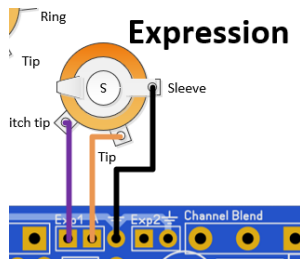

**!** When you do not want to incorporate an expression pedal, you will need to jumper the **Exp1** and **A** pads. **!**



## Modifications

### Transistors

**Q3, Q5, Q6 and Q7** are based on the BS170P as used in a lot of Zvex pedals. You can use the regular BS170 instead of BS170P but note that the pinout is in reverse! Soundwise they are exactly the same.

### Op amp and charge pump

You should use a OPA134 instead of the OPA132. It is available in DIP8 and is often cheaper while it makes no audible difference. Note that TI does not make OPA132 in DIP8 so if you find them on Ebay or AliExpress, they are fakes! You can use almost any pin compatible single opamp chip as long as it is able to take -9V (Vcc-) and +18V (Vcc+). You could also buy a OPA132 (SMD) and a converter board to keep true to the original.

### Pot values

The Gain pot (**P1**) is reportedly better off using a A50k instead of a B25k. Same goes for Channel Blend (**P2**) using a C1k instead of a B1k. An A25K for Boost (**P5**) is also ok.

### Hissing and squealing

As mentioned before this is a very high gain effect, using the gain switch will introduce some extra hissing and potentially some squealing. I added an optional extra filter capacitor **C15** and it is reported that using a 22uF in there will lessen the squealing. By default you should not use and solder a jumper in C15!



## Troubleshooting

All PCB's have been 100% factory e-tested and out of every batch I receive I build an effect to double check, so there should not be a connection problem on the PCB itself.

The board is not working (at all), what now?

- Check if your 9V is plugged in correctly (and/or soldered correctly on the board). Pay special attention to the polarity.
- Check that you oriented the capacitors, IC's ,transistors and diodes the right way. SMF, MKT and ceramic capacitors as well as resistors do not need to be oriented. A likely sign of incorrect capacitors and/or orientation is when an effect is sputtering, rumbling or “motorboating”.
- Check if you used the correct values of the components. For resistors you can look here: <http://www.diyaudioandvideo.com/Electronics/Color/>
- Double and triple check your soldering! A loose or cold solder can be really bad for your board.
- Replace the IC and/or transistors, one might be defective. Before doing that first unplug the 9V and wait for 5 seconds.
- Check that you have good/high grade components. A lot of Chinese sourced parts are fakes (especially high end opamps, audio capacitors, vintage diodes and transistors) so be careful that you source your parts from reliable suppliers.
- If you still get a lot of squealing at high gain settings, make sure you make the off board wiring as neat and as possible. Keep the wires short and do not mix the wires with high and low output signals.



# Have Mercy v2.2

## Schematic

Clean Boost (Post OD)

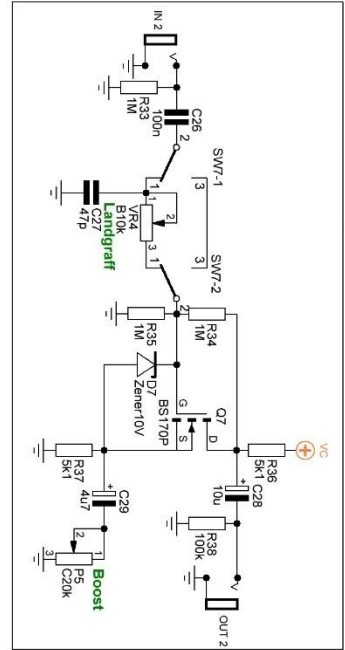

Power

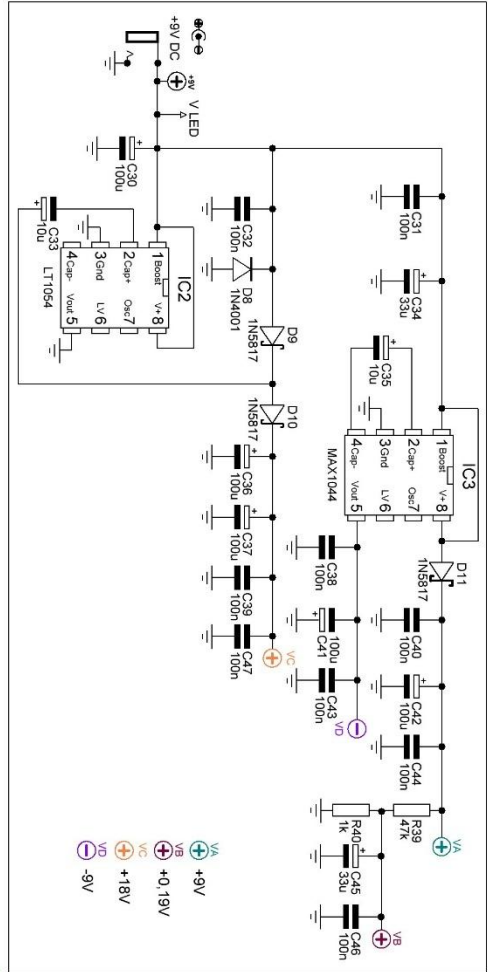

All parts must be rated 25V+

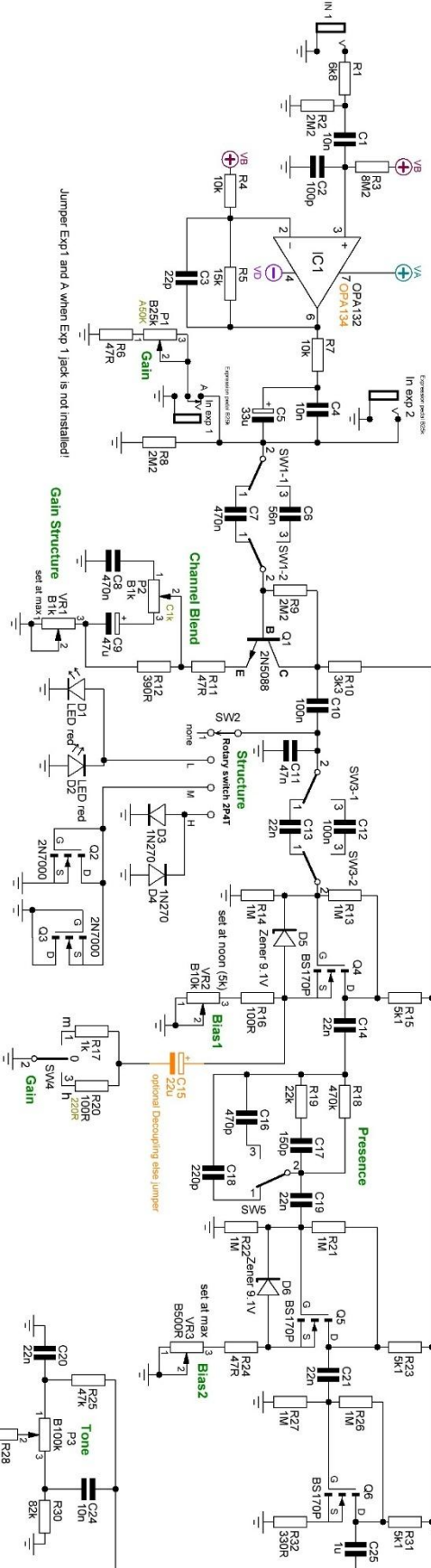

The orange marked components are optional mods.  
Internal pots (VR) marked as 'set at max' means full clockwise (to the right).

**Have Mercy v2.2**  
Drawn by: Arnold Dijkstra (2024)  
Based on the Bogner La Grange, ZVEX Box of Rock, ZVEX SHO and Lovepedal COT50 with thanks to freestompboxes.org and tagboardeffects.blogspot.nl

Manufacturers and product names are mentioned solely for circuit identification, and where applicable their trademarks are the property of their respective owners who are in no way associated or affiliated with the author. No cooperation or endorsement is implied.