

Have Mercy

Building instructions

v2.2

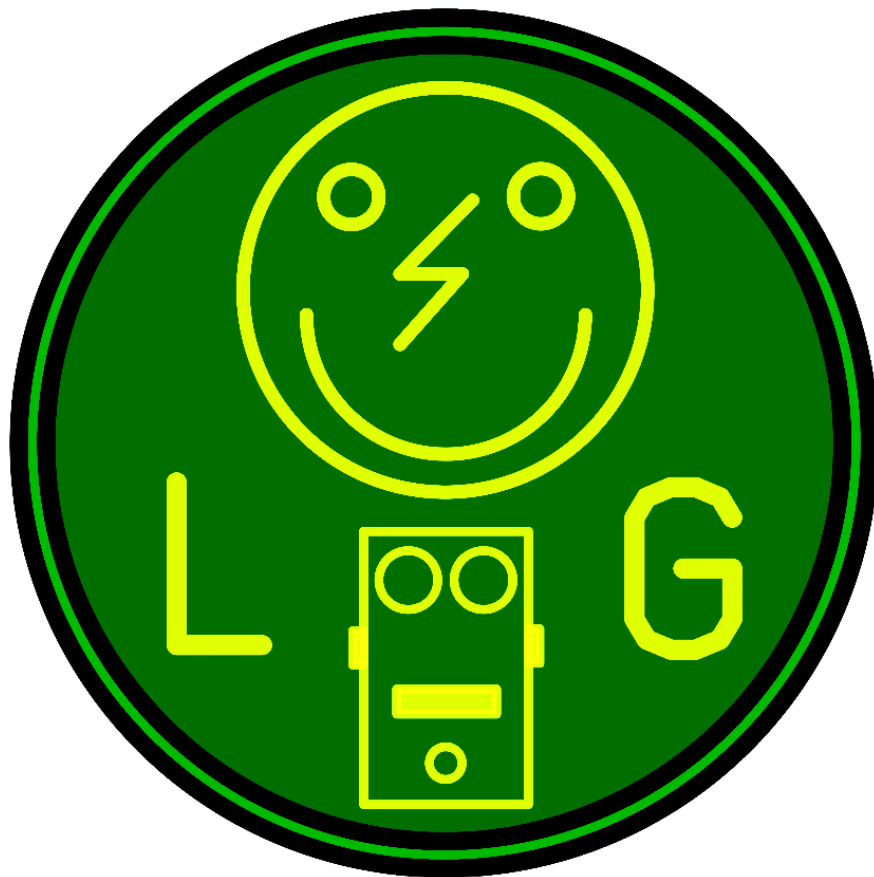

Table of contents

Main PCB layout	3
Components Main PCB.....	4
Footswitch PCB.....	5
Build sequence	6
Calibrating to stock factory settings.....	7
Switch settings.....	7
Off board wiring	8
Modifications.....	9
Transistors	9
Op amp and charge pump.....	9
Pot values	9
Hissing and squealing	9
Incorporating an expression pedal.....	10
Troubleshooting	11
Schematic	12

Read this entire manual thoroughly before you start building the effect! There are some available options and you should choose which one you want to incorporate before starting your build.

Last update: 05-07-2024



Main PCB layout

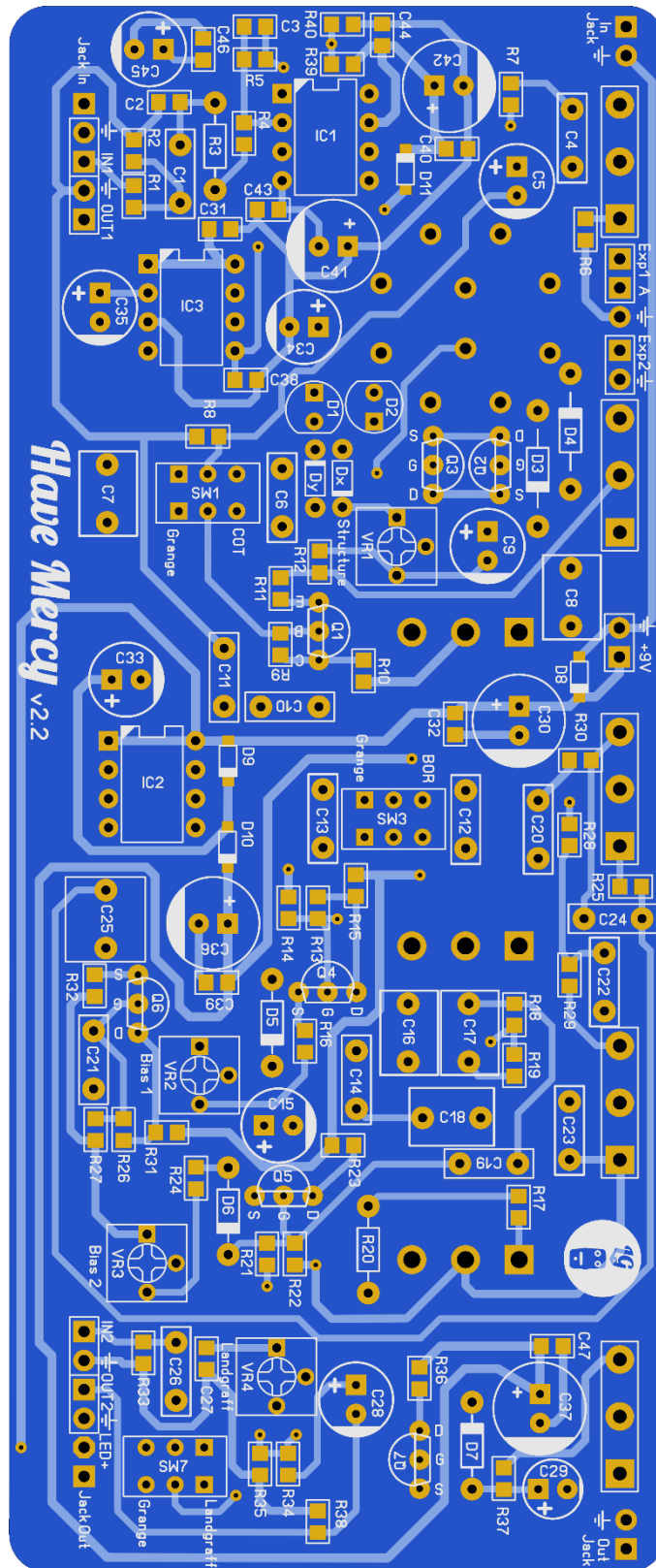

Dimensions: 52,5 mm x 130 mm
2.1 inch x 5.15 inch

Manufacturers and product names are mentioned solely for circuit identification, and where applicable their trademarks are the property of their respective owners who are in no way associated or affiliated with the author. No cooperation or endorsement is implied.



Components Main PCB

Part	Value	Comment	Part	Value	Comment
C1	10n	SMF/MKT/FKP2	D1	LED 5mm red	
C4	10n	SMF/MKT/FKP2	D2	LED 5mm red	
C5	33u	Electrolytic 25V+	D3	1N270	Germanium Diode
C6	56n	SMF/MKT/FKP2	D4	1N270	Germanium Diode
C7	470n	SMF/MKT/FKP2	D5	Zener 9.1V	
C8	470n	SMF/MKT/FKP2	D6	Zener 9.1V	
C9	47u	Electrolytic 25V+	D7	Zener 10V	
C10	100n	SMF/MKT/FKP2	Dx	1N4148	OPTIONAL
C11	47n	SMF/MKT/FKP2	Dy	1N4148	OPTIONAL
C12	100n	SMF/MKT/FKP2	IC1	OPA134	Original OPA132 (SOIC-8)
C13	22n	SMF/MKT/FKP2	IC2	LT1054	
C14	22n	SMF/MKT/FKP2	IC3	ICL7660S	Alternative LT1054
C15	22u	OPTIONAL	P1	B25k	Gain
C16	470p	SMF/MKT/FKP2	P2	B1k	Channel Blend
C17	150p	SMF/MKT/FKP2	P3	B100k	Tone
C18	220p	SMF/MKT/FKP2	P4	A100k	Volume
C19	22n	SMF/MKT/FKP2	P5	C20k	Boost
C20	22n	SMF/MKT/FKP2	Q1	2N5088	
C21	22n	SMF/MKT/FKP2	Q2	2N7000	
C22	2n2	SMF/MKT/FKP2	Q3	2N7000	
C23	2n2	SMF/MKT/FKP2	Q4	BS170p	BS170 has reversed pinout
C24	10n	SMF/MKT/FKP2	Q5	BS170p	BS170 has reversed pinout
C25	1u	SMF/MKT/FKP2	Q6	BS170p	BS170 has reversed pinout
C26	100n	SMF/MKT/FKP2	Q7	BS170p	BS170 has reversed pinout
C28	10u	Electrolytic 25V+	R3	8M2	1% metalfilm MF0207
C29	4u7	Electrolytic 25V+	R20	100R	1% metalfilm MF0207
C30	100u	Electrolytic 25V+	SW1	DPDT	Cap (MSS22D18)
C33	10u	Electrolytic 25V+	SW2	2P4T Rotary	Structure
C34	33u	Electrolytic 25V+	SW3	DPDT	Cap 2 (MSS22D18)
C35	10u	Electrolytic 25V+	SW4	SP3T	Gain (On-Off-On)
C36	100u	Electrolytic 25V+	SW5	SP3T	Presence (On-Off-On)
C37	100u	Electrolytic 25V+	SW6	SPDT	Variac (On-On)
C41	100u	Electrolytic 25V+	SW7	DPDT	Landgraff bypass (MSS22D18)
C42	100u	Electrolytic 25V+	VR1	B1k	Gain Structure
C45	33u	Electrolytic 25V+	VR2	B10k	Bias 1
Jack In		Stereo Jack	VR3	B500R	Bias 2
Jack Out		Mono Jack	VR4	B10k	Landgraff
DC		DC jack			

All parts need to be 25V+ rated

A=Log, B=Lin, C=Rev. Log

Links to Tayda parts included

Manufacturers and product names are mentioned solely for circuit identification, and where applicable their trademarks are the property of their respective owners who are in no way associated or affiliated with the author. No cooperation or endorsement is implied.



Footswitch PCB

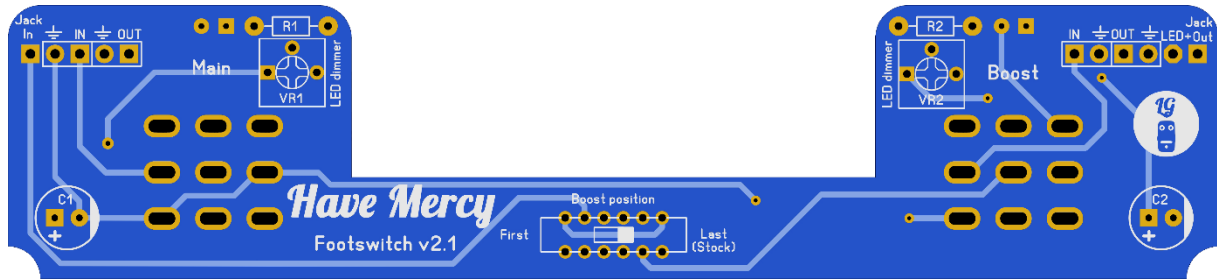

Part	Value	Comment	Part	Value	Comment
R1	390R	MF0207	SW1	3PDT	
R2	390R	MF0207	SW2	3PDT	
VR1		LED dependent	SW3	4PDT	Akeys MSS-42D01 (Aliexpress)
VR2		LED dependent	C1	22u	Electrolytic 25V+
D1	See below	LED flange	C2	22u	Electrolytic 25V+
D2	See below	LED flange			

R1, R2, C1, C2, SW3, VR1 and **VR2** should be soldered to the topside. **SW1, SW2, D1** and **D2** should be soldered on the bottom side. When using larger sized capacitors for **C1** and **C2** you might consider soldering them to the bottom side.

VR1 and **VR2** vary depending on the LED you want to use for **D1** and **D2**. For bright clear 3mm LED's you can use these values and links to Tayda parts for **D1/D2** and **VR1/VR2**:

Red : [B10k](#) (set at 6k8)
Blue : [B20k](#) (set at 15k)
Orange : [B5k](#) (set at 1k8)
Pink : [B20k](#) (set at 9k1)
White : [B50k](#) (set at 18k)

The original has 2 white LED's, but I personally prefer Red (**D1**) and Orange (**D2**).

The brighter you turn the LED the shorter its lifespan!

You will also need some [AWG22 or AWG24](#) hookup wire, some shrink tubing and a 1590XX enclosure.



Build sequence

Soldering this board can be very complicated for some people since the solder pads are very close together. Use a magnifying glass to make the job easier.

The trick to soldering a PCB is to work from small to big components. My building sequence suggestions in this section are based on the parts I used myself. Sometimes some components are smaller (or bigger) so always use your own common sense and change the order accordingly. Usually capacitors differ a lot in size depending on their rating and value.

Note: Do not blow on your solder in an attempt to cool it down. That can result in a bad join that might corrode! Also take extra care not to short components.

Before you start soldering, read the modifications section and decide which mod you want to incorporate. You must read the part about incorporating the expression pedal else you might get into trouble at the end of your build!

Start by soldering the resistors and jumpers (if needed). When needed you can create a jumper using a spare piece of lead from a resistor, diode or capacitor. Next come the diodes (not the LEDs).

If you want to experiment with other transistors then you could socket them instead of soldering them to the board. You'll need a some 20 SIL sockets, break off the sockets and solder them to the board. Now is the time to solder these sockets on the PCB as well as the socket for the IC. Do not place the socketed transistors and IC until you are finished with all soldering and off board wiring!

Now continue by soldering the internal trimpots (**VR**) then solder the SMF and MKT capacitors. Now finish with soldering the transistors (if not socketed), LEDs and the Electrolytics.

If you are not using the drill templates, I suggest you now drill the holes in your enclosure so you can use it during the off board wiring.

Note: Really take some time to determine where to place the pots, switches, jacks and PCB in the enclosure before you start drilling. Measure twice, drill once. There is a Tayda drill template if you want to use a predrilled enclosure.

The component side of the PCB is the Top side. The pots and switches need to be soldered on the bottom side of the PCB (PCB mounted pots). The rectangle pad on the PCB indicates pin 1 of the pot. You can break off the pin I marked with the yellow circle using a small pair of pliers.



If you are planning on incorporating the **expression pedal**, you will need an extra jack as mentioned in that section. If not, you will need to solder a jumper between the pads marked **Exp 1** and **A**

Calibrating to stock factory settings

Once everything is connected, you should calibrate **VR1 – VR4** to give you your optimum gain.

VR1 (Gain Structure) : 100% (full clockwise/right)

VR2 (Bias 1) : 50% (12 o'clock/middle)

VR3 (Bias 2) : 100% (full clockwise/right)

VR4 (Landgraff) : 100% (full clockwise/right)

These are the stock factory setting for the original pedal.

VR1 will subtract some gain when lowered on the COT part of the pedal. **VR2** can add or subtract some gain on the 1st stage and **VR3** will subtract some gain of the 2nd stage when lowered.

VR4 is a sort of pre gain for the boost part as used in the original Landgraff design. This will only have effect if you set **SW7** to Landgraff.

This is a very loud effect and prone to squeal at high gain. If that happens, adjust the settings of especially **VR1-VR3** as you desire to tame the beast. If you think you are lost in the calibration, just return the settings to the default settings and start over. You can also leave the settings at stock and choose to raise **R20** to 150R or 220R.

Switch settings

	Structure		Gain	Variac	Presence
1 (full counter clockwise)	None	Top	High	Off	High
2	LEDs	Middle	Low		Low
3	Mosfet	Bottom	Middle	On	Middle
4 (full clockwise)	Germanium				

Here is an example of what the enclosure could look like:



Off board wiring

Off board wiring is very easy using the special designed Footswitch PCB. It fits a 9V battery however be warned that a depelting battery will not be able to deliver the 9V needed for the voltage doubler to work and produce 18V. I would recommend to use a good 9V adapter instead.

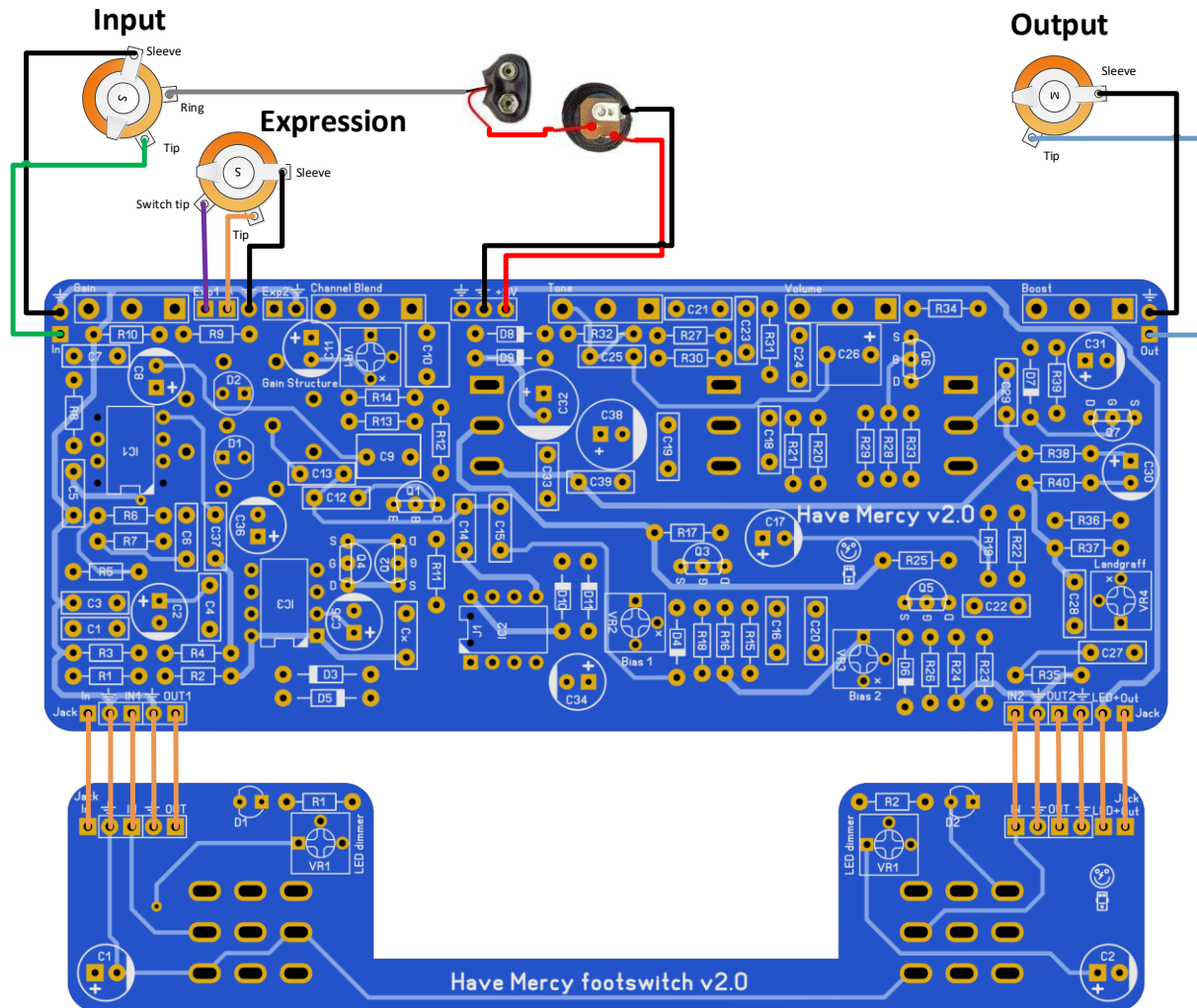



Modifications

Transistors

Q3, Q5, Q6 and Q7 are based on the BS170P as used in a lot of Zvex pedals. You can use the regular BS170 instead of BS170P but note that the pinout is in reverse! Soundwise they are exactly the same.

Op amp and charge pump

You should use a OPA134 instead of the OPA132. It is available in DIP8 and is often cheaper while it makes no audible difference. Note that TI does not make OPA132 in DIP8 so if you find them on Ebay or AliExpress, they are fakes! You can use almost any pin compatible single opamp chip as long as it is able to take -9V (Vcc-) and +18V (Vcc+). You could also buy a OPA132 (SMD) and a converter board to keep true to the original.

Pot values

The Gain pot (**P1**) is reportedly better off using a A50k instead of a B25k. Same goes for Channel Blend (**P2**) using a C1k instead of a B1k. An A25K for Boost (**P5**) is also ok.

Hissing and squealing

As mentioned before this is a very high gain effect, using the gain switch will introduce some extra hissing and potentially some squealing. I added an optional extra filter capacitor **C15** and it is reported that using a 22uF in there will lessen the squealing. By default you should not use and solder a jumper in C15!

Incorporating an expression pedal

There are 2 ways to incorporate an expression pedal. The first being as mentioned in the original pedal. The original adds a expressionpedal parallel to the gainpot in the pedal. This results in around 12.5k ($25k // 25k // 2M2 = \text{approx. } 12.5k$) and so makes the gain act a bit different.

To wire this configuration you should jumper **Exp1** and **A** and add a monojack to Exp2 and ground like this:

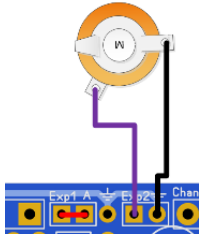

The other way is to replace the internal gain pot when inserting the expressionpedal. This gives you more usable gain options when using different resistor values as it will use the full extent of the pot taper. This can be wired like this with a [switchable](#) jack:

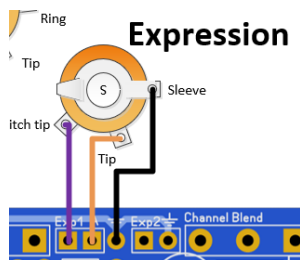

! When you do not want to incorporate an expression pedal, you will need to jumper the **Exp1** and **A** pads. **!**



Troubleshooting

All PCB's have been 100% factory e-tested and out of every batch I receive I build an effect to double check, so there should not be a connection problem on the PCB itself.

The board is not working (at all), what now?

- Check if your 9V is plugged in correctly (and/or soldered correctly on the board). Pay special attention to the polarity.
- Check that you oriented the capacitors, IC's ,transistors and diodes the right way. SMF, MKT and ceramic capacitors as well as resistors do not need to be oriented. A likely sign of incorrect capacitors and/or orientation is when an effect is sputtering, rumbling or “motorboating”.
- Check if you used the correct values of the components. For resistors you can look here: <http://www.diyaudioandvideo.com/Electronics/Color/>
- Double and triple check your soldering! A loose or cold solder can be really bad for your board.
- Replace the IC and/or transistors, one might be defective. Before doing that first unplug the 9V and wait for 5 seconds.
- Check that you have good/high grade components. A lot of Chinese sourced parts are fakes (especially high end opamps, audio capacitors, vintage diodes and transistors) so be careful that you source your parts from reliable suppliers.
- If you still get a lot of squealing at high gain settings, make sure you make the off board wiring as neat and as possible. Keep the wires short and do not mix the wires with high and low output signals.

