

Purple Vibe

Building instructions

v1.2

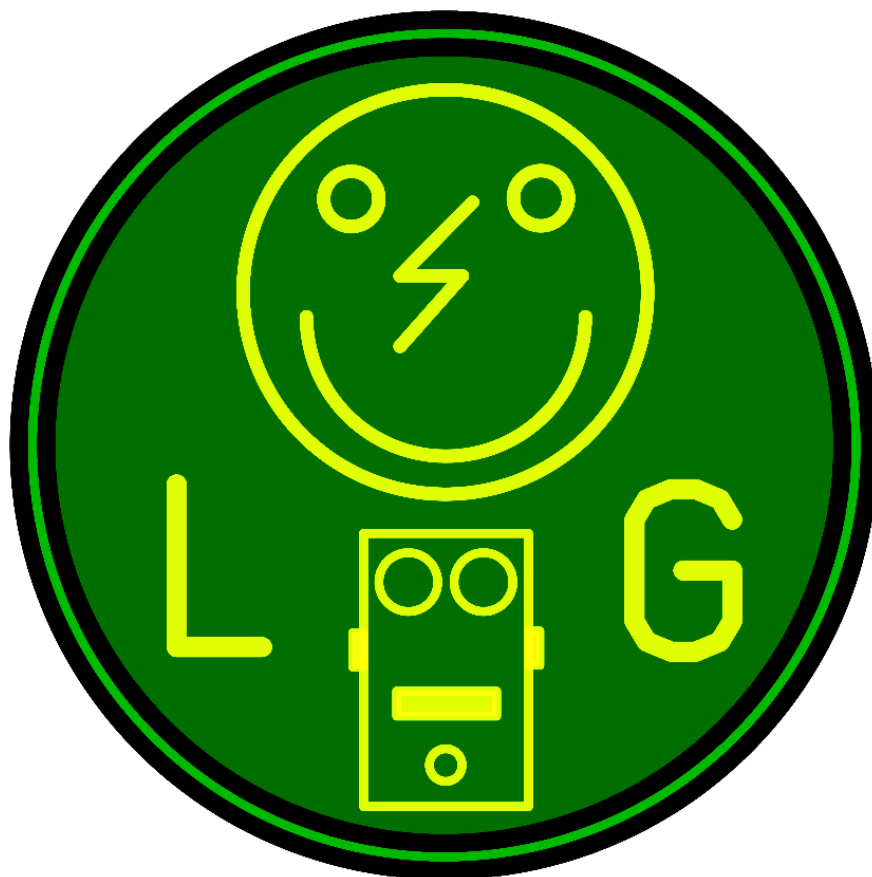

Table of contents

PCB layout	3
Components	4
Bill of Materials.....	6
Options	7
Build sequence	10
Off board wiring	11
Tone selector	11
Mode selector	12
Buffer switch	13
Pots.....	13
Footswitches.....	14
Setup.....	16
Troubleshooting	17
Schematic	18

Changelog to v1.0/v1.0.1/v1.2:

- Added 15V/18V voltage selection for audiopath
- Added extra filtering on +9V
- Reversed pins on Offset fixed
- Moved the position of SC slightly to better align with the other SCx pads
- Updated parts footprints and increased lamp enclosure size
- Small silkscreen errors fixed

Read this entire manual thoroughly before you start building the effect! There are many available options and you should choose which one you want to incorporate before starting your build.

Last update: 26-02-2021



PCB layout

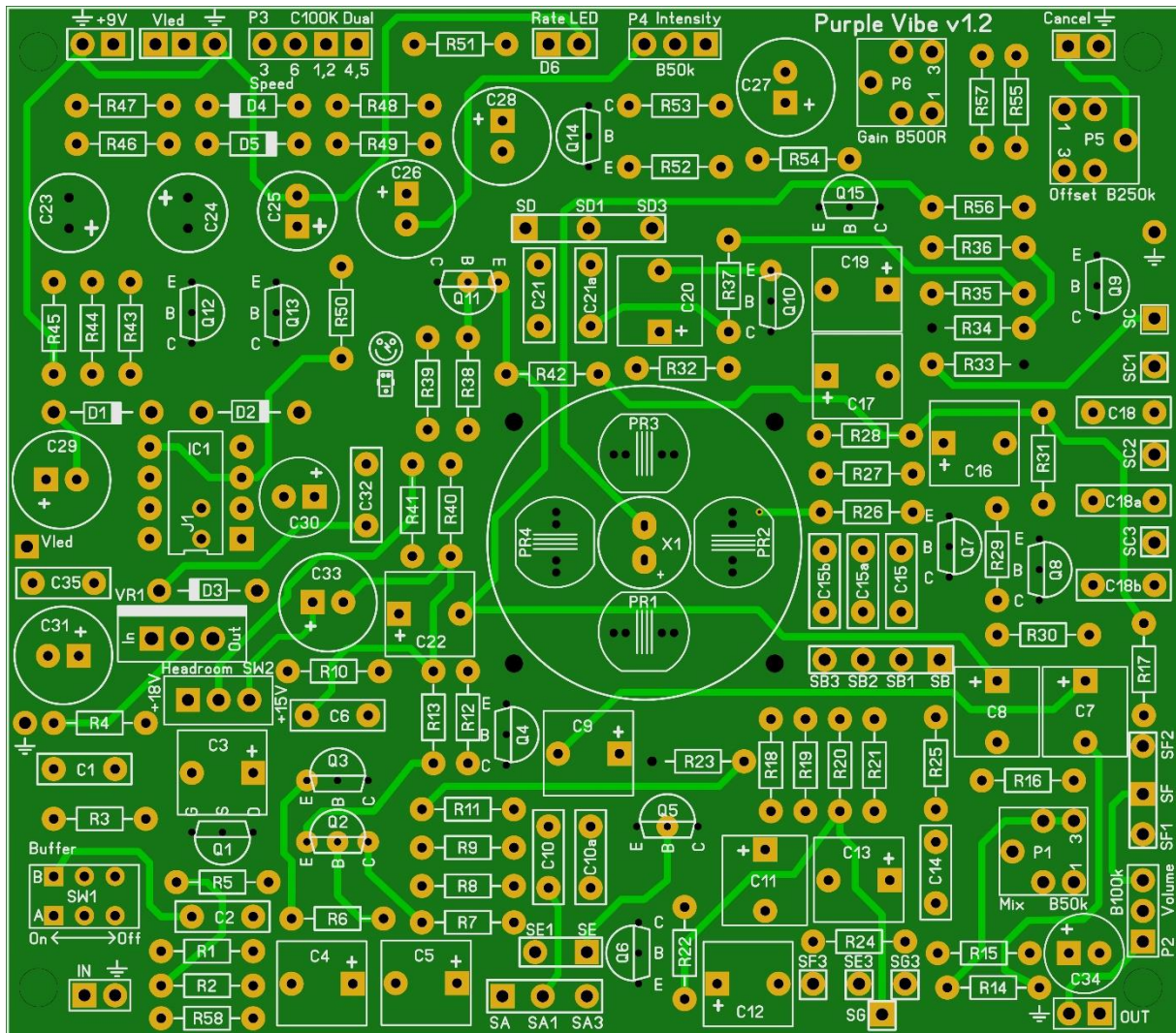

Dimensions: 97 mm x 85,5 mm
3,82 inch x 3,37 inch

Manufacturers and product names are mentioned solely for circuit identification, and where applicable their trademarks are the property of their respective owners who are in no way associated or affiliated with the author. No cooperation or endorsement is implied.



Components

All parts must be rated 25V+

Name	Value	Comment	Name	Value	Comment
C1	100n	SMF	C32	100n	SMF
C2	100n	SMF	C33	100u	Electrolyte
C3	1u	SMF	C34	10u	Electrolyte
C4	1u	SMF	C35	100n	SMF
C5	1u	SMF	Q1	J201	
C6	330p	Ceramic	Q2	2N5089	
C7	1u	SMF	Q3	2N5088	
C8	1u	SMF	Q4	2N5088	
C9	1u	SMF	Q5	2N5088	
C10	15n	SMF	Q6	2N5088	
C10a	4n7	SMF	Q7	2N5088	
C11	1u	SMF	Q8	2N5088	
C12	1u	SMF	Q9	2N5088	
C13	1u	SMF	Q10	2N5088	
C14	68n	SMF	Q11	2N5088	
C15	220n	SMF	Q12	2N5088	
C15a	100n	SMF	Q13	2N5088	
C15b	3n3	SMF	Q14	2N5087	
C16	1u	SMF	Q15	2N5088	
C17	1u	SMF	D1	1N4001	
C18	470p	Ceramic	D2	1N5817	
C18a	47n	SMF	D3	1N5817	
C18b	2n2	SMF	D4	1N914	
C19	1u	SMF	D5	1N914	
C20	1u	SMF	D6	LED	Rate indicator
C21	4n7	SMF	IC1	LT1054	
C21a	1n	SMF	LDR1	9203	GL-5539,Silonex NLS-7532
C22	1u	SMF	LDR2	9203	GL-5539,Silonex NLS-7532
C23	1u	Electrolyte	LDR3	9203	GL-5539,Silonex NLS-7532
C24	1u	Electrolyte	LDR4	9203	GL-5539,Silonex NLS-7532
C25	1u	Electrolyte	P1	B50k	MIX
C26	10u	Electrolyte	P2	B100k	VOLUME
C27	10u	Electrolyte	P3	C100K Dual	SPEED
C28	1u	Electrolyte	P4	B50k	INTENSITY/DEPTH
C29	100u	Electrolyte	P5	B250K	GAIN
C30	47u	Electrolyte	P6	B500R	OFFSET
C31	470u	Electrolyte			

A=Log, B=Lin, C=Rev. Log



Name	Value	Comment	Name	Value	Comment
R1	22k		R33	100k	
R2	47k		R34	47k	
R3	1k		R35	100k	
R4	1M		R36	4k7	
R5	4k7		R37	4k7	
R6	1M		R38	4k7	
R7	1M		R39	100k	
R8	100k		R40	47k	
R9	47k		R41	68k	
R10	5k6		R42	22k	
R11	4k7		R43	3k3	
R12	3k3		R44	2M2	
R13	1k2		R45	4k7	
R14	75K		R46	220k	
R15	75K		R47	4k7	
R16	47k		R48	4k7	
R17	220k		R49	220k	
R18	4k7		R50	4k7	
R19	100k		R51	10k	
R20	47k		R52	1M	Lower up to 22k if needed
R21	100k		R53	1k	
R22	4k7		R54	4k7	
R23	4k7		R55	47k	
R24	47k		R56	47k	
R25	100k		R57	22R	
R26	4k7		R58	1M	
R27	100k		SW1	DPDT	Buffer/Vintage
R28	47k		SW2	SPDT	Headroom
R29	100k		VR1	LM7815	<u>not</u> LM78L15
R30	4k7		X1	18v Lightbulb	alternative 12v
R31	4k7				
R32	4k7				

Bill of Materials

Resistors			Semiconductors		
Amount	Part	Type	Amount	Part	Type
1	22R		1	1N4001	
2	1k		2	1N5817	
1	1k2		2	1N914	
4	3k3		2	LED	Rate indicator/Status LED
17	4k7		1	LED	Bicolor common cathode
1	5k6		1	LT1054	
1	10k		1	J201	
2	22k		1	2N5087	
10	47k		12	2N5088	
1	68k		1	2N5089	
2	75K		1	LM7815	
9	100k		Other		
3	220k		Amount	Part	Type
5	1M		2	4P3T	Mode and Tone switch
2	2M2		1	DPDT	Input buffer
4	9203	or GL-5539, GL-5549, NLS-7532	1	SPDT	or DPDT/3PDT footswitch
1	B500R	Trimpot Bourns 3362P	1	3PDT	Footswitch
1	B50k	Trimpot Bourns 3362P	1	18v	Lightbulb
1	B250K	Trimpot Bourns 3362P	2	Jack	Mono input jack
1	B50k	16mm Alpha	1	Box	Hammond 1590DD
1	B100k	16mm Alpha	1	DC	2,1mm DC jack
1	C100K Dual	16mm Alpha	4	Spacer	Plastic PCB mounting spacers
Capacitors			1	DIL-8	Socket for IC
Amount	Part	Type	1	Mini SPDT	Headroom switch
1	30p	Ceramic (optional for C6 mod)	Orange marked parts are optional and you can read about these choices in the off board wiring section.		
1	330p	Ceramic			
1	470p	Ceramic			
1	1n	SMF			
1	2n2	SMF			
1	3n3	SMF			
2	4n7	SMF			
1	15n	SMF			
1	47n	SMF			
1	68n	SMF			
5	100n	SMF			
1	220n	SMF			
14	1u	SMF			
4	1u	Electrolyte			
3	10u	Electrolyte			
2	47u	Electrolyte			
2	100u	Electrolyte			
1	470u	Electrolyte			

A=Log, B=Lin, C=Rev. Log

Options

Before you start, you must decide which options you want to incorporate in the build. The original Univibe™ only has a **Mode** selector (Chorus/Vibrato). The Neovibe™ (GeoFX) was one of the first reconstructions of the original and followed by the Harbinger One™ (Madbean) which added an input buffer and charge pump. In this build there is also an added **Tremolo mode** as well as a **Tone selector** that works with all modes. In essence it is a 3 position switch that adds different combinations of caps in the 4 different phase stages. The optional input buffer and chargepump are also incorporated. I salute GeoFX and Madbean for their work and strongly suggest that you check all their work!

If you want to be as close as possible to the original then you can opt out on these mods. If you want to incorporate all options then you can skip this part and start soldering, but it is still a good read.

1. Capacitors

The original Univibe™ the 1uF caps were electrolytes. Most clones replaced them with SMF (stacked metal film) caps. To give you the ability to keep it as original as possible, I marked the polarity of these caps on the PCB so you can use electrolytes instead of SMF. You can recognize these SMF caps on the PCB by their rectangle marking. If a capacitor is marked as a circle, it is meant to be an electrolyte anyway.

If you decided not to use SMF 1uF caps then make sure you source your 1uF electrolytes with care! Buy Nichicon or Elna quality caps to keep the sound quality as best you can.

It is reported that replacing the **C6** with a **30p** will brighten the overall tone.

There have been questions if C23-C28 caps should still be SMF. As these caps are in the LFO, it is not in the audiopath and you can choose MKT/Wima FKP or even ceramic. The LFO only makes the lamp blink and the normal (cheap) electrolytes do a great job there.

To be honest, I used all MKT/Wima for the values between 1nF and 2uF for all caps and these sound great. So great that I really cannot hear the difference with SMF.

2. Input buffer

The original has no input buffer, but there are a lot of people who have a problem with the volume drop when engaging the effect. To prevent this, there is an input buffer ready on the PCB. But if you do not want to use it, please do the following:

DO NOT SOLDER: **R3, R4, R5, C1, C2** and **Q1**

EXTRA JUMPERS: On **SW1** row A and B connect pad 2 and 3.

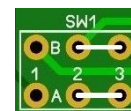

Jumpers can be made by using excess lead wires that you cut off the resistors.

You can optionally replace **R2** with a **2M2** to raise the signal to unity although it might get a bit distorted.



3. Tone selection

If you want to leave out the **tone selection** and want to use only the original cap values in the phase stages then you will need to do the following:

DO NOT SOLDER: C10a, C15a, C15b, C18a, C18b, C21a and Switch 3 (4P3T rotary)

EXTRA JUMPERS: Connect SA to SA1, SB to SB1, SC to SC1, SD to SD1

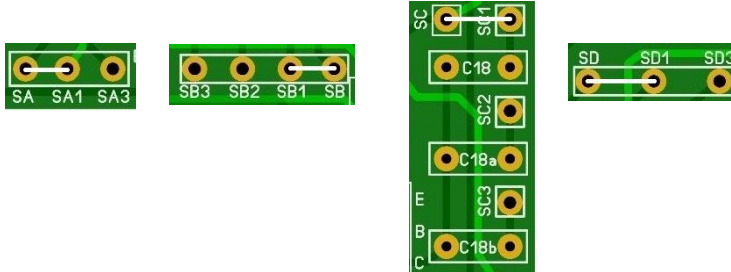

4. Tremolo mode

If you do not want the tremolo mode then you will need to do the following:

DO NOT SOLDER: R24, R25, C12, C14

EXTRA JUMPER: SE to SE1



You will now need a **DPDT** switch instead of the **4P3T** rotary mode switch.

Do not yet connect this switch but wait till the off board wiring section!

5. Lamps and LDRs

There are a lot of options for choosing the combination that is right for you. Regarding lamps, you could use a 12V filament lamp or a 12V / 18V bi pin JKL lamp (8097SBP/8099SBP).



LDR's can be 9203's, GL-5539, GL-5549 or Silonex NLS-7532. Of course if you have personal lamp/LDR preferences, do not hesitate to use them!

I personally found the combination of a 18V Lamp and upright GL-5539 LDR's to be a good combination. But there are companies out there on the web that sell great ready to use lamp/LDR kits which you might prefer.

Note: The tremolo modus requires higher than vintage spec LDRs to really work. The GL-5539 has been tested with success, other LDRs may have different results. You could also mix different LDRs. For example a GL-5539 as LDR1 (the essential LDR for the tremolo) and 9203's for the rest.

6. Mix

P1 is a mix pot to vary the mix of dry and wet signal to the output. It does not have a great yield so if you want to leave it out do as follows:

DO NOT SOLDER: P1

EXTRA JUMPERS: In P1 connect pad 3 to 2 and 1 to 2

Also the value of R14 and R15 should be changed to **100k**

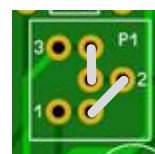



7. Power supply

The PCB is designed to use a regular 9V adapter and raise the voltage to 18V with a built in charge pump. I do not advise the use of a battery in this build so I left it out in the descriptions! But feel free to have a different opinion and incorporate it anyway. Some prefer to use a dedicated 18V wall wart and in that case you must leave out the onboard charge pump by doing the following:

DO NOT SOLDER: **D1**, **D3**, **C30**, **C31** and **IC1**

EXTRA JUMPER: Short **D3** with a jumper

D2 should be a **1N5818** or **1N5819**.

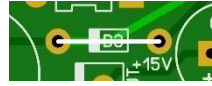

If your build makes unwanted whistling noises, it could be that you do not have a genuine LT1054. Sometimes it helps to connect/solder the pads of **J1** to prevent this noise.

SW2 (Headroom) gives you the option to use either +15V in the audio path (as in the original Univibe) or +18V (as introduced by the Harbinger one). If you do not want those options, just leave out **SW2** and connect either the middle pad of **SW2** to the round path to get permanent +15V or the middle pad to the rectangle pad to get permanent +18V.

Never connect all 3 pads together! That will short-circuit the board.

8. Rate LED

Changing the value of **R53** will change the brightness of the rate indicator LED. Lower the value to make the LED burn brighter, but not under 360R

9. True bypass

This build is adapted to be used with true bypass switching. In the original there was no true bypass, only a switch that turned off the lamp. The wiring of all these options will be discussed in the special off board wiring section, just know that if you are not using true bypass then you can leave out the optional pulldown resistor **R58**.

10. Light shield

You can make a light shield out of almost anything. The max outer diameter is 23 mm (0,9 inch). You can use a plastic cap and put aluminum foil inside as reflecting surface. There are 4 extra pads around the lamp/LDR's so you can attach some wire to and secure your light shield.

Ok, just a small bite out of the LDR orientation discussion. You can solder the LDR's flat on the PCB. This way you really need a reflecting light shield, else barely any light will reach the LDR. If you put the LDRs in an upright position (directly facing the lamp) you do not really need a light shield as the enclosure will make sure that no real light comes through and the LDR is close enough to the lamp to catch enough light.

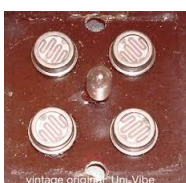

Flat LDR

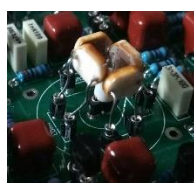

Up right LDR



Some simple light shield samples.



Build sequence

Soldering this board can be very complicated for some people since the solder pads are very close together. Use a magnifying glass to make the job easier. The trick to soldering a PCB is to work from small to big components. My building sequence suggestions in this section are based on the parts I used myself. Sometimes some components are smaller (or bigger) so always use your own common sense and change the order. Usually capacitors differ a lot in size depending on their rating.

Note: Do not blow on your solder in an attempt to cool it down. That will possibly result in a bad join that might corrode!

Start by soldering the resistors, then the diodes and then the ceramic capacitors.

If you want to experiment with other transistors, lamps or LDR's then you could socket them instead of soldering them to the board. You'll need a some 20 SIL sockets, break off the sockets and solder them to the board. Now is the time to solder these sockets on the PCB as well as the socket for the IC. Place the transistors, IC, LDR's and lamp once you are finished with all soldering and off board wiring!

If you are using small horizontal 6mm trim pots then solder them now (P1,P5 and P6).

Now continue by soldering small SMF capacitors (<1 uF), then the MKT capacitors then the 1uF SMF and then the smaller electrolytes (<470uF). If you are using upright precision trim pots (P1,P5,P6) then now is the time to solder them on the PCB. Finish by soldering the 470uF and then the LM7815.

I suggest you now drill the holes in your enclosure so you can use it during the off board wiring.

Note: Really take some time to determine where to place the pots, switches, jacks and PCB in the enclosure before you start drilling. Measure twice, drill once.

You are almost ready to rock, well... not really. The difficult part starts now.

Off board wiring

Tone selector

This build is a beast to wire, so we'll do it in steps. We'll start by soldering the most difficult part, the 4P3T **Tone selector** and after that the **Mode selector**. For those who have never worked with a 4P3T rotary switch, pay special attention. Start by determining which poles are connected to the commons (those are the 4 center pins in the switch) in the 3 positions. You can do this by using a DMM (digital multi meter). Most of them have a special setting (eg diode test) that shows if 2 points are directly connected. Most give a beep or other signal to point out that the points are directly connected. Note down on a piece of paper how they are connected. Chances are that your diagram will be the same as mine, but don't assume directly that it is!

Start by connecting A1 to A2 and D1 and D2 directly on the switch. After that, connect the pins to the according points on the PCB. I suggest you start by soldering the wires on the pins on the switch and then test their length by measuring it to the PCB. I also suggest you twist the wires to shield from additional noise. It may also be a good idea to first measure it inside your enclosure.

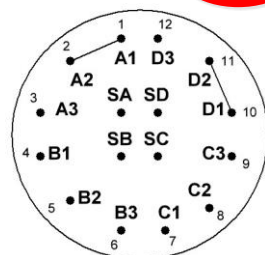
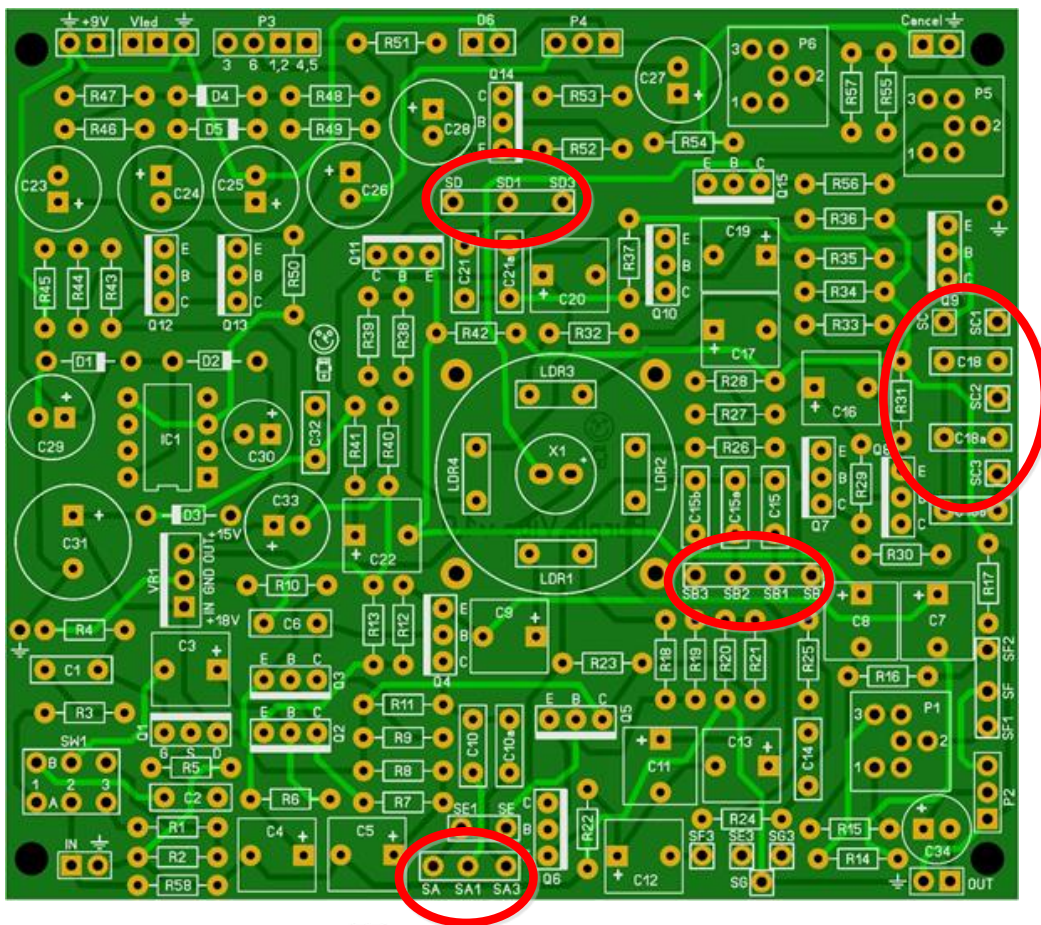

SW3: Tone

Position 1: UniVibe
 Position 2: VooDooVibe
 Position 3: Resley Tone



Mode selector

If you decided not to use the Tremolo mode then you will not need the 4P3T but a SPDT (or DPDT if you want a LED indicator). Take a good look at the diagram and wire accordingly:

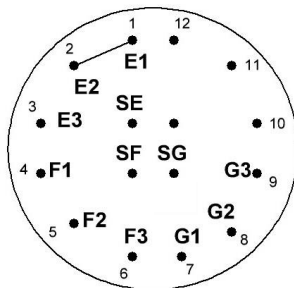
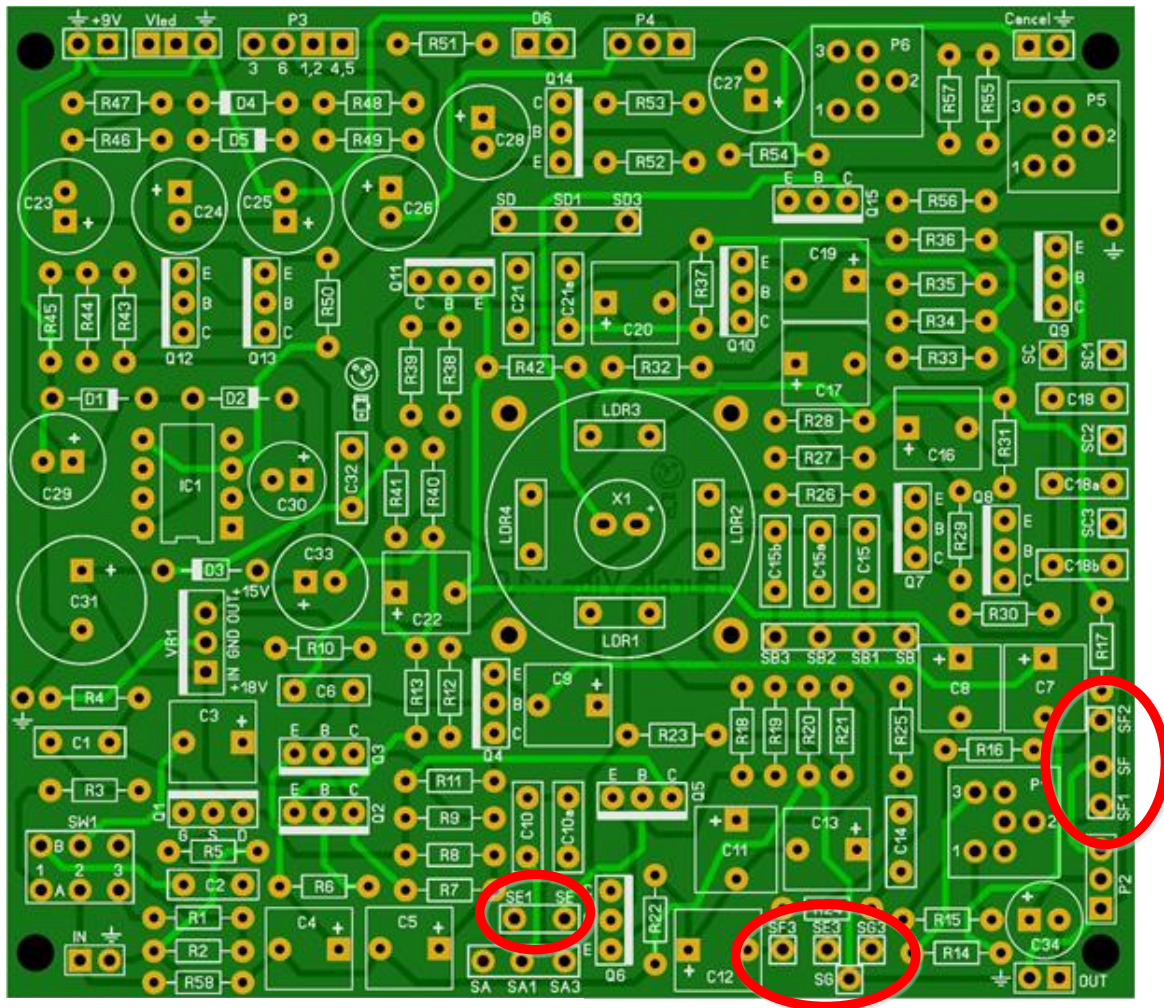

Switch 4: Mode

Position 1: Chorus
Position 2: Vibrato
Position 3: Tremolo

(Chorus) SF1 SF SF2 (Vibrato)

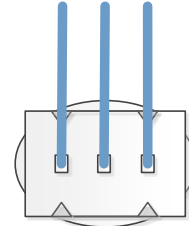

Start by connecting E1 to E2 on the switch. G1 and G2 are not connected. If you are in a creative mood, you could use the unused poles on the 4P3T for a RGB LED (common cathode). Connect the LED anodes to pins 10,11 and 12. The cathode to a spare ground pad on the PCB and the leftover common on the switch to a Vref pad on the top left of the PCB.

If you are using the SPDT then you could also use a DPDT instead and add a bicolor common cathode LED. Wire the anodes each to one of the outer pins of the extra pin row on the switch. Wire the center pin to Vled and the common cathode to an extra ground pad on the pcb.

Buffer switch

SW1 marks the input buffer switch pads (see bottom left of the PCB image on the previous page). Notice it is in the same shape as a DPDT switch so it should be easy to solder the wires to the switch.

Pots

We can now continue with the pots. Again let's start with the most difficult one, **P3** the Speed pot (C100k DUAL). Bend the bottom 3 pins carefully so they are flat. Use some leftover lead wire to connect pins 1,2,4 and 5 together and then attach wires to pins 1,5 and 6 like this:

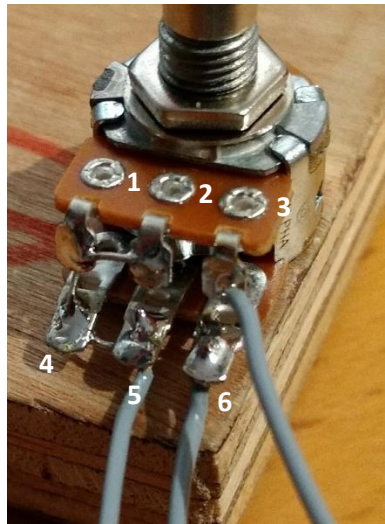

Connect the wires to P3: wire 3 to pad 3, wire 6 to pad 6 and wire 5 to either pad 1,2 or 4,5.

Next we connect P2 and P4. These are standard pots so all you need to do is connect the pins in the right order. In the pictures below you see the pin numbering of the pots. If you look at the pads of P2 and P4 you'll see that pin 1 is marked as a square pad. Solder the wires accordingly and it is always a good idea to twist the wires together to have a sort of extra shielding against external noise.



Blue = pin 1
White = pin 2
Yellow = pin 3

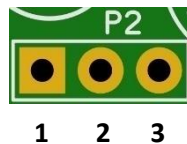

Footswitches

The wiring of the footswitch and LED's are the last steps. First of wired as true bypass with lamp cancellation. If you do not want to cancel the lamp then leave out the grey wire from the footswitch to the **cancel pad** on the PCB:

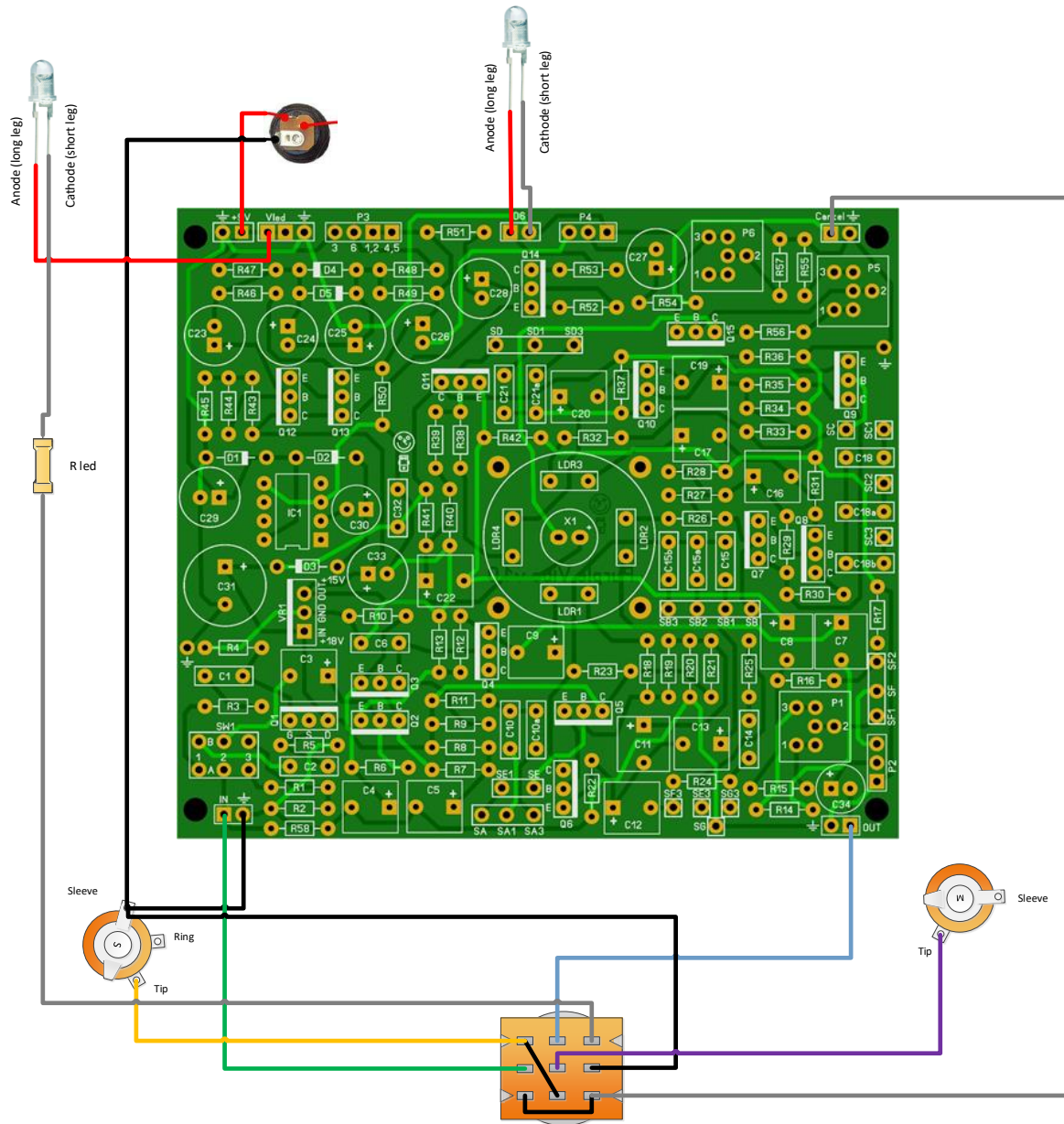

Note that this wiring is using a sort of star grounding and the output connector must make good electrical contact with the enclosure else the grounding will not work properly and the effect might start to buzz loudly.



As mentioned in the beginning, the original unit did not have true bypass, only lamp cancellation. You can wire it like that with this PCB, although I would not recommend it. Since only the lamp is turned off, all additional noise the unit generates will be audible and in your signal path. But if you really prefer vintage you can wire it like this:

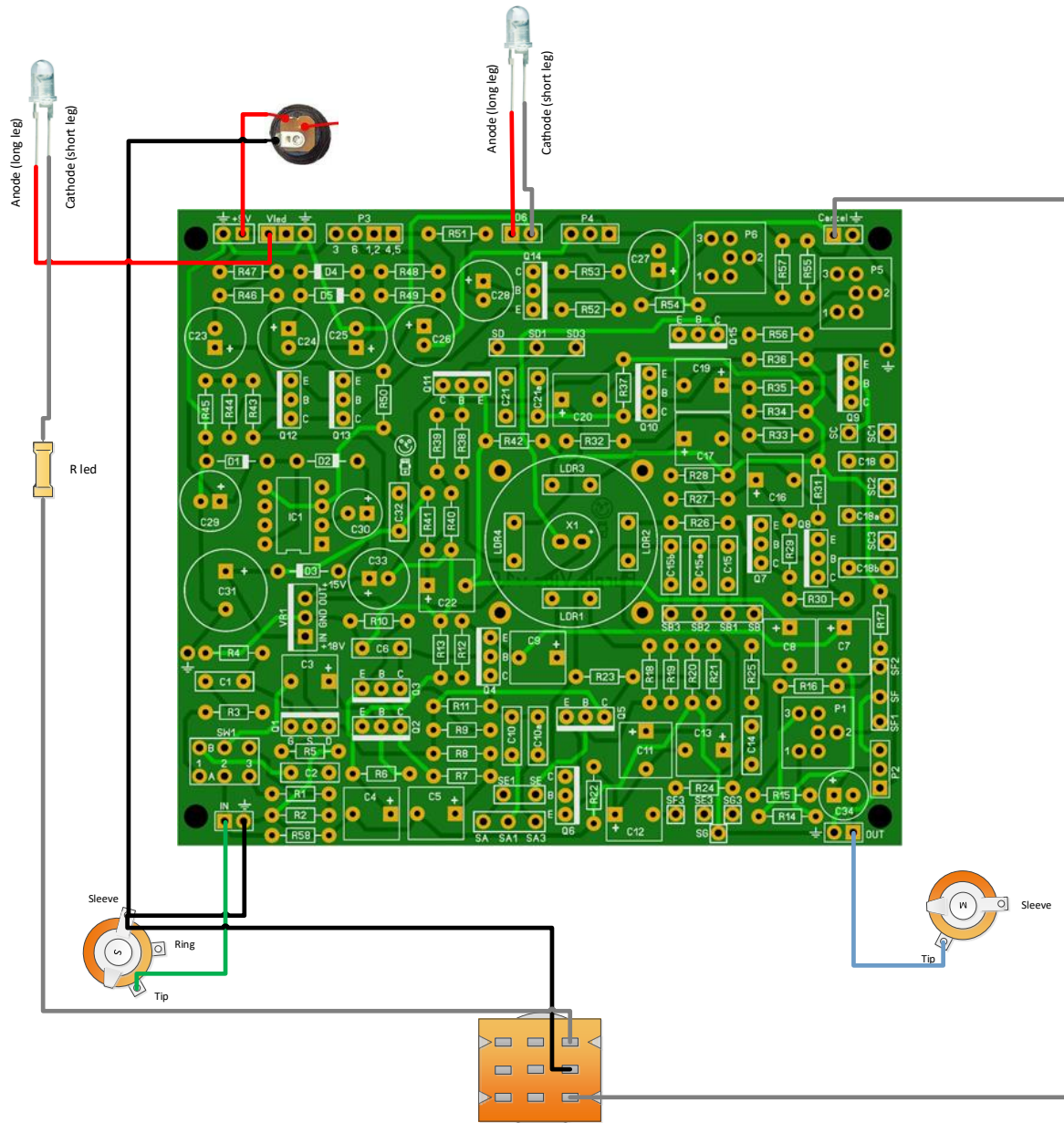

Note that **R led** is a **3k3** resistor. You can change this value depending on the type of LED you use but 3k3 is safe enough for almost all LEDs.

It is now time to place your transistors, IC, lamp and LDR's in the sockets if needed.



Setup

You must first set the trim pots before you connect the DC jack. Start with these settings:

- **P1** (mix) at 12 o'clock
- **P5** (gain) at 12 o'clock
- **P6** (offset) all the way to the right

Now, connect the DC and start turning up P5 until the lamp is bright enough. Then, turn P6 to the left until you really see the light turn off.

There is no exact scientific setting for the pots. It is all a question of taste. The settings are just a suggestion so experiment at will. Do not forget you will need to use a light shield when testing the PCB in an open enclosure. Without a light shield, the effect will not do its magic and the dry signal will be dominant. Take your time finding the sweet spots. Also test the settings in conjunction with the **Intensity** pot. It will take time to get it right but once you have it this effect will change your life!

Another method to set the effect up from scratch is as follows:

1. Turn **Volume** (P2) and **Intensity** (P4) to the max and **Speed** (P3) and **Mix** (P1) to halfway.
2. Turn the **Gain** (P5) until you get a moderate but not too bright burning lamp.
3. Now you need to determine the floor value of the lamp by turning the **Offset** (P6). The higher you set this the darker the floor value of the lamp will be. If you open the Offset all the way up then the lamp will turn off at the bottom of the sweep. Turn it till you find your sweet spot.

NB. There is a theoretical possibility that you blow your lamp when setting the gain to high when using a 12V bulb. Be careful setting this pot!

In the original design there are no gain pot (**P5**) and offset pot (**P6**). Instead there are fixed resistors. If you want to build it as the original (*not recommended* due to differences in lightbulbs), leave out **P5, P6, R55**. Change **R56** to 100k and **R57** to 200R. Short pin 3 to pin 2 on **P6** and pin 1 and 2 on **P5**.



Troubleshooting

All PCB's have been 100% factory e-tested and out of every batch I receive I build an effect to double check, so there should not be a connection problem on the PCB itself.

The board is not working (at all), what now?

- Check if your 9V is plugged in correctly (and/or soldered correctly on the board). Pay special attention to the polarity.
- Check that you oriented the capacitors, IC's ,transistors and diodes the right way. SMF, MKT and ceramic capacitors as well as resistors do not need to be oriented. A likely sign of incorrect capacitors and/or orientation is when an effect is sputtering, rumbling or "motorboating".
- Check if you used the correct values of the components. For resistors you can look here: <http://www.diyaudioandvideo.com/Electronics/Color/>
- Double and triple check your soldering! A loose or cold solder can be really bad for your board.
- Replace the IC and/or transistors, one might be defective. Before doing that first unplug the 9V and wait for 5 seconds.
- Check that you have good/high grade components. A lot of Chinese sourced parts are fakes (especially high end opamps, audio capacitors, vintage diodes and transistors) so be careful that you source your parts from reliable suppliers.



Schematic

Purple Vibe v1.2
Drawn by: Arnold Dijkstra (2016-2021)

Based on the original UniVibe with adaptations of the NeoVibe (Geofrex), Herbringer One (Medbean), mods posted on Tagboardeffects and DIY Stompboxes

