

Analog Engineer's

Pocket Reference

Art Kay and Tim Green, Editors

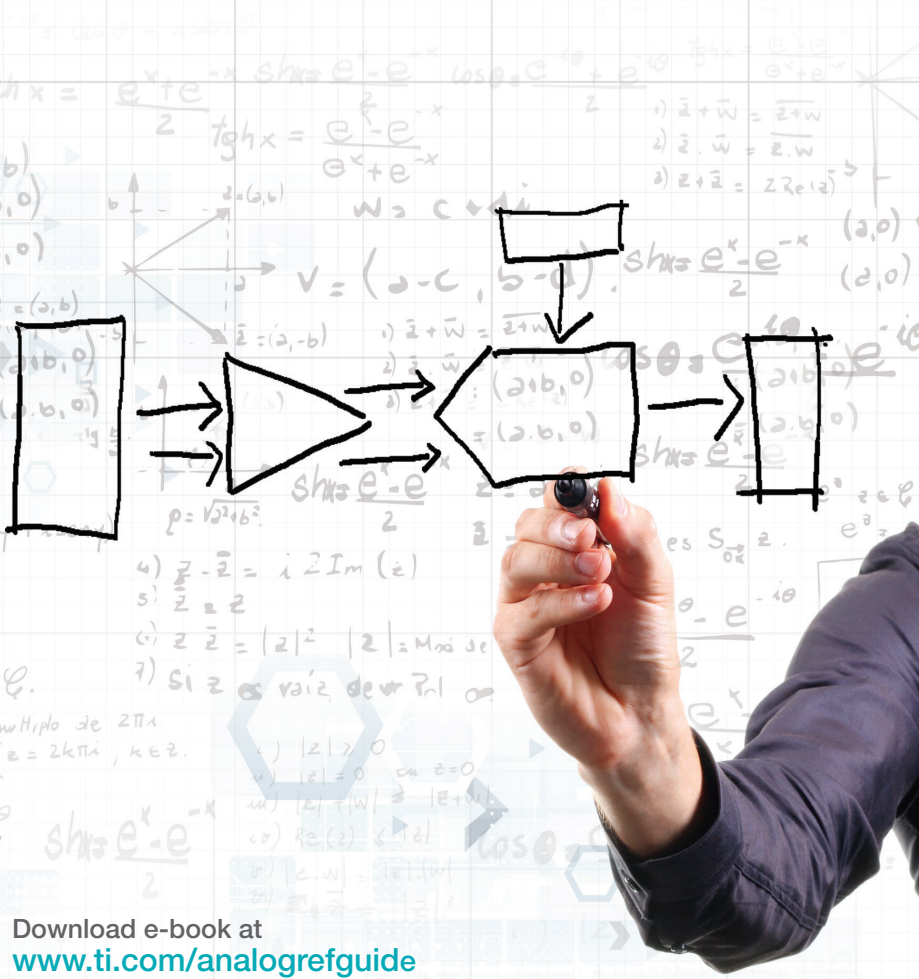

Download e-book at
www.ti.com/analogrefguide

Analog Engineer's Pocket Reference

Fifth Edition

Edited by:

Art Kay and Tim Green

Special thanks for technical contribution and review:

Kevin Duke

Rafael Ordonez

John Caldwell

Collin Wells

Ian Williams

Thomas Kuehl

Pete Semig

Abhijeet Godbole

Ravi Singh

David Wang

© Copyright 2019 Texas Instruments Incorporated. All rights reserved.

Message from the editors:

This pocket reference is intended as a valuable quick guide for often used board- and system-level design formulae. This collection of formulae is based on a combined 50 years of analog board- and system-level expertise. Much of the material herein was referred to over the years via a folder stuffed full of printouts. Those worn pages have been organized and the information is now available via this guide in a bound and hard-to-lose format!

Here is a brief overview of the key areas included:

- Key constants and conversions
- Discrete components
- AC and DC analog equations
- Op amp basic configurations
- OP amp bandwidth and stability
- Overview of sensors
- PCB trace R, L, C
- Wire L, R, C
- Binary, hex and decimal formats
- A/D and D/A conversions

We hope you find this collection of formulae as useful as we have. Please send any comments and/or ideas you have for the next edition of the *Analog Engineer's Pocket Reference* to

artkay_timgreen@list.ti.com

Additional resources to explore:

TI Precision Labs

ti.com/precisionlabs

- On-demand courses and tutorials ranging from introductory to advanced concepts that focus on application-specific problem solving
- Hands-on labs and evaluation modules (EVM) available
 - TIPL Op Amps experimentation platform, ti.com/TIPL-amp-evm
 - TIPL SAR ADC experimentation platform, ti.com/TIPL-adc-evm

Analog Engineer's Circuit Cookbooks

ti.com/circuitcookbooks

- Simplify and speed system design with comprehensive library of sub-circuit
- Step-by-step instructions, basic formulas, schematic diagrams and SPICE simulations

The Signal e-book

ti.com/signalbook

- Short, bite-sized lessons on on op-amp design topics, such as offset

Analog Wire Blog

ti.com/analogwire

- Technical blogs written by analog experts that include tips, tricks and design techniques

TI Designs

ti.com/tidesigns

Ready-to-use reference designs with theory, calculations, simulations schematics, PCB files and bench test results

DIY Amplifier Circuit Evaluation Module (DIYAMP-EVM)

ti.com/DIYAMP-EVM

- Single-channel circuit evaluation module providing SC70, SOT23 and SOIC package options in 12 popular amplifier configurations

Dual-Channel DIY Amplifier Circuit Evaluation Module (DUAL-DIYAMP-EVM)

ti.com/dual-diyamp-evm

- Dual-channel circuit evaluation module in an SOIC-8 package with 10 popular amplifier configurations

TINA-TI simulation software

ti.com/tool/tina-ti

- Complete SPICE simulator for DC, AC, transient and noise analysis
- Includes schematic entry and post-processor for waveform math

Analog Engineer's Calculator

ti.com/analogcalc

- ADC and amplifier design tools, noise and stability analysis, PCB and sensor tools

TI E2E™ Community

ti.com/e2e

- Support forums for all TI products

Conversions	7
Physical constants / Standard decimal prefixes	8
Metric conversions	9
Temperature conversions	10
Error conversions (ppm and percentage)	11
Discrete components	13
Resistor color code	14
Standard resistor values	15
Practical capacitor model and specifications	16
Practical capacitors vs frequency	17
Capacitor type overview	18
Standard capacitance values / Capacitance marking and tolerance	19
Diodes and LEDs	20
Bipolar junction transistors (BJT)	21
Junction field effect transistors (JET)	22
Metal oxide semiconductor field effect transistor (MOSFET)	24
Analog	27
Resistor equations / Ohm's law and voltage divider equation	28
Power equations	29
Capacitor equations	30
Inductor equations	31
Equation for charging an RC circuit	32
Equation for discharging an RC circuit	33
Capacitor with constant current source	34
RMS and mean voltage	35
Logarithmic mathematical definitions / Alternative notations	38
dB definitions	39
Log scale	40
Time to phase shift	41
Bode plots: Poles	42
Pole (equations)	43
Bode plots (zeros)	44
Zero (equations)	45
Amplifier	47
Basic op amp configurations	48
Simple non-inverting amp with C_f filter	51
Simple inverting amp with C_f filter	52
Differential filter cutoff	53
Calculating amplifier offset voltage	54
Op amp bandwidth	55
Small signal step response	56
Full power bandwidth	57
Large signal response (slew rate)	58
Settling time	59
Combining noise sources / Averaging noise sources	60
Noise bandwidth calculation	61
1/f total noise calculation	62
Thermal noise calculations	63
Op amp noise model	64
Total noise calculations	65
AC response versus frequency (dominant 2-pole system)	66
Transient overshoot (dominant 2-pole system)	67
Stability open loop SPICE analysis	68
Stability transient square wave lab test	70
Stability AC sine wave lab test	71
Power dissipation calculation	72
Electrical overstress (EOS) protection	74
PCB and wire	77
PCB printed circuit board conductor spacing	78
Self-heating of PCB conductors on inner layers	79
PCB trace resistance	80
PCB trace resistance for 1 oz-Cu	81
PCB trace resistance for 2 oz-Cu	82
Common package types and dimensions	83
PCB parallel plate capacitance	84
PCB microstrip capacitance and inductance	85

PCB and wire (cont.)

PCB adjacent copper traces	86
PCB via capacitance and inductance	87
Coaxial cable information	88
Coaxial cable equations	89
Resistance per length for different wire types (AWG)	90
Maximum current for wire types	91

Sensor 93

Temperature sensor overview	94
IC temperature sensor overview	95
RTD equation temperature to resistance ($T \geq 0\text{C}$ and $T < 0\text{C}$)	96
RTD equation resistance to temperature ($T < 0\text{C}$ or $R_{\text{rtd}} < R_0$)	97
Diode equation vs temperature	98
Diode voltage versus temperature	99
Type J thermocouples translating temperature to voltage (ITS-90 standard)	100
Type J thermocouples translating voltage to temperature (ITS-90 standard)	101
Type K thermocouples translating temperature to voltage (ITS-90 standard)	102
Type K thermocouples translating voltage to temperature (ITS-90 standard)	103
Thermistor: Resistance to temperature, Steinhart-Hart equation	104

Digital 105

Numbering systems: binary, decimal and hexadecimal	106
Data formats	108
Digital logic thresholds	109
CMOS logic thresholds	110
SPI (Serial peripheral interface) hardware overview	111
SPI data latching	112
SPI critical edge	113
SPI modes	114
I ² C bus (Inter-integrated circuit) hardware overview	115
I ² C addressing	116
I ² C communication	117
I ² C setup, hold and rising timing	119
I ² C pull-up resistor selection	120

ADC 121

ADC definitions	122
ADC resolution for unipolar	123
ADC resolution for bipolar	124
Resolution voltage vs. full-scale range	125
Quantization error of ADC	126
Signal-to-noise ratio (SNR) from quantization noise only	127
Total harmonic distortion (V_{RMS})	128
Total harmonic distortion (dBc)	129
Ac signals	130
Dc signals	131
Settling time and conversion accuracy	132
ADC system noise calculation	134
Effect of clock jitter on ADC SNR	135

DAC 137

DAC definitions	138
DAC errors	139
DAC non-linearity	144
DAC total unadjusted error	146

Multiplexer 147

CMOS switch construction	148
ON-resistance (R_{ON})	149
R_{ON} flatness / Effective op amp gain including MUX R_{ON}	150
ON and OFF capacitance ($C_{\text{ON}}/C_{\text{OFF}}$)	152
MUX settling time with C_{LOAD} and R_{LOAD}	153
Leakage current	154
Charge injection	155
Bandwidth (BW)	156
Channel-to-channel crosstalk (X_{TALK})	157
OFF-isolation	158
Total harmonic distortion plus noise	159

Conversions

- Standard decimal prefixes
- Metric conversions
- Temperature scale conversions
- Error conversions (ppm and percentage)



Table 1: Physical constants

Constant	Symbol	Value	Units
Speed of light in a vacuum	c	$2.997\,924\,58 \times 10^8$	m/s
Permittivity of vacuum	ϵ_0	$8.854\,187\,817\,620 \times 10^{-12}$	F/m
Permeability of free space	μ_0	$1.256\,637\,0614 \times 10^{-6}$	H/m
Planck's constant	h	$6.626\,069\,57 \times 10^{-34}$	J•s
Boltzmann's constant	k	$1.380\,648\,8 \times 10^{-23}$	J/K
Faraday's constant	F	$9.648\,533\,99 \times 10^4$	C/mol
Avogadro's constant	N_A	$6.022\,141\,29 \times 10^{23}$	1/mol
Unified atomic mass unit	m_u	$1.660\,538\,921 \times 10^{-27}$	kg
Electronic charge	q	$1.602\,176\,565 \times 10^{-19}$	C
Rest mass of electron	m_e	$9.109\,382\,15 \times 10^{-31}$	kg
Mass of proton	m_p	$1.672\,621\,777 \times 10^{-27}$	kg
Gravitational constant	G	$6.673\,84 \times 10^{-11}$	Nm ² /kg ²
Standard gravity	g_n	9.806 65	m/s ²
Ice point	T_{ice}	273.15	K
Maximum density of water	ρ	1.00×10^3	kg/m ³
Density of mercury (0°C)	ρ_{Hg}	$1.362\,8 \times 10^4$	kg/m ³
Gas constant	R	8.314 462 1	J/(K•mol)
Speed of sound in air (at 0°C)	c_{air}	3.312×10^2	m/s

Table 2: Standard decimal prefixes

Multiplier	Prefix	Abbreviation
10^{12}	tera	T
10^9	giga	G
10^6	mega	M
10^3	kilo	k
10^{-3}	milli	m
10^{-6}	micro	μ
10^{-9}	nano	n
10^{-12}	pico	p
10^{-15}	femto	f
10^{-18}	atto	a

Table 3: Imperial to metric conversions

Unit	Symbol	Equivalent	Unit	Symbol
inches	in	25.4 mm/in	millimeter	mm
mil	mil	0.0254 mm/mil	millimeter	mm
feet	ft	0.3048 m/ft	meters	m
yards	yd	0.9144 m/yd	meters	m
miles	mi	1.6093 km/mi	kilometers	km
circular mil	cir mil	$5.067 \times 10^{-4} \text{ mm}^2/\text{cir mil}$	square millimeters	mm^2
square yards	yd^2	0.8361 m^2	square meters	m^2
pints	pt	0.5682 L/pt	liters	L
ounces	oz	28.35 g/oz	grams	g
pounds	lb	0.4536 kg/lb	kilograms	kg
calories	cal	4.184 J/cal	joules	J
horsepower	hp	745.7 W/hp	watts	W

Table 4: Metric to imperial conversions

Unit	Symbol	Conversion	Unit	Symbol
millimeter	mm	0.0394 in/mm	inch	in
millimeter	mm	39.4 mil/mm	mil	mil
meters	m	3.2808 ft/m	feet	ft
meters	m	1.0936 yd/m	yard	yd
kilometers	km	0.6214 mi/km	miles	mi
square millimeters	mm^2	1974 cir mil/ mm^2	circular mil	cir mil
square meters	m^2	1.1960 yd^2/m^2	square yards	yd^2
liters	L	1.7600 pt/L	pints	pt
grams	g	0.0353 oz/g	ounces	oz
kilograms	kg	2.2046 lb/kg	pounds	lb
joules	J	0.239 cal/J	calories	cal
watts	W	$1.341 \times 10^{-3} \text{ hp/W}$	horsepower	hp

Example

Convert 10 mm to mil.

Answer

$$10 \text{ mm} \times 39.4 \frac{\text{mil}}{\text{mm}} = 394 \text{ mil}$$

Table 5: Temperature conversions

$^{\circ}\text{C} = \frac{5}{9} (^{\circ}\text{F} - 32)$	Fahrenheit to Celsius
$^{\circ}\text{F} = \frac{9}{5} (^{\circ}\text{C}) + 32$	Celsius to Fahrenheit
$\text{K} = ^{\circ}\text{C} + 273.15$	Celsius to Kelvin
$^{\circ}\text{C} = \text{K} - 273.15$	Kelvin to Celsius

Table 6: Error conversions

$\text{Error}(\%) = \frac{\text{Measured} - \text{Ideal}}{\text{Ideal}} \times 100$	Error in measured value
$\text{Error}(\% \text{ FSR}) = \frac{\text{Measured} - \text{Ideal}}{\text{Full - scale range}} \times 100$	Error in percent of full-scale range
$\% = \frac{\text{ppm}}{10^6} \times 100$	Part per million to percent
$\text{m}\% = \frac{\text{ppm}}{10^6} \times 100 \times 1000$	Part per million to milli-percent
$\text{ppm} = \% \times 10^4$	Percent to part per million
$\text{ppm} = \text{m}\% \times 10$	Milli-percent to part per million

Example

Compute the error for a measured value of 0.12V when the ideal value is 0.1V and the range is 5V.

Answer

$$\text{Error}(\%) = \frac{0.12\text{V} - 0.1\text{V}}{0.1\text{V}} \times 100 = 20\% \quad \text{Error in measured value}$$

$$\text{Error}(\% \text{ FSR}) = \frac{0.12 - 0.1\text{V}}{5\text{V}} \times 100 = 0.4\% \quad \text{Percent FSR}$$

Example

Convert 10 ppm to percent and milli-percent.

Answer

$$\frac{10 \text{ ppm}}{10^6} \times 100 = 0.001\% \quad \text{Part per million to percent}$$

$$\frac{10 \text{ ppm}}{10^6} \times 100 \times 1000 = 1 \text{ m}\% \quad \text{Part per million to milli-percent}$$

Table 7: Conversion between codes, mV, %, and ppm

	Codes	mV	%	ppm
Codes	*	$\text{Codes} \cdot \left(\frac{V_{\text{FSR}}}{2^N}\right) \cdot 1000$	$\text{Codes} \cdot \left(\frac{1}{2^N}\right) \cdot 100$	$\text{Codes} \cdot \left(\frac{1}{2^N}\right) \cdot 10^6$
mV	$\text{mV} \cdot \left(\frac{2^N}{V_{\text{FSR}} \cdot 1000}\right)$	*	$\text{mV} \cdot \left(\frac{1}{V_{\text{FSR}} \cdot 1000}\right) \cdot 100$	$\text{mV} \cdot \left(\frac{1}{V_{\text{FSR}} \cdot 1000}\right) \cdot 10^6$
%	$\% \cdot \left(\frac{2^N}{100}\right)$	$\% \cdot \left(\frac{V_{\text{FSR}} \cdot 1000}{100}\right)$	*	$\% \cdot \left(\frac{10^6}{100}\right)$
ppm	$\text{ppm} \cdot \left(\frac{2^N}{10^6}\right)$	$\text{ppm} \cdot \left(\frac{V_{\text{FSR}} \cdot 1000}{10^6}\right)$	$\text{ppm} \cdot \left(\frac{1}{10^6}\right) \cdot 100$	*

Where

N = resolution of ADC

V_{FSR} = full scale range of ADC in voltage. Full scale range is double for a bipolar ADC compared with unipolar ADC.

Codes, %, and ppm = the equivalent value ADC codes, percentage, and parts per million

Discrete Components

- Resistor color code
- Standard resistor values
- Capacitance specifications
- Capacitance type overview
- Standard capacitance values
- Capacitance marking and tolerance

Discrete components

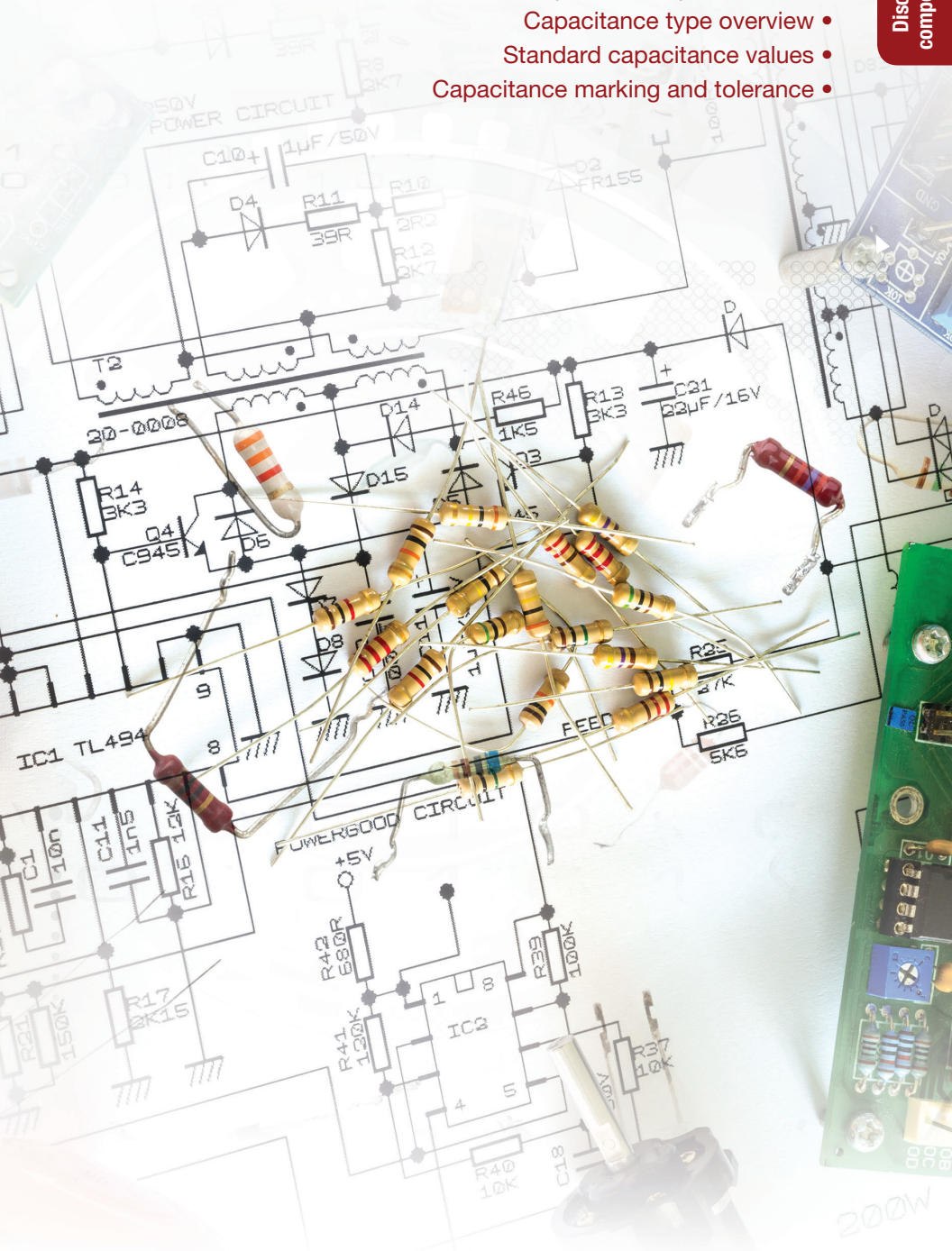

Table 8: Resistor color code

Color	Digit	Additional Zeros	Tolerance	Temperature Coefficient	Failure Rate
Black	0	0		250	
Brown	1	1	1%	100	1
Red	2	2	2%	50	0.1
Orange	3	3		15	0.01
Yellow	4	4		25	0.001
Green	5	5	0.5%	20	
Blue	6	6	0.25%	10	
Violet	7	7	0.1%	5	
Grey	8	8	0.05%	1	
White	9	9			
Gold	-na-	-1	5%		
Silver	-na-	-2	10%		
No Band	-na-	-na-	20%		

4 band example: yellow violet orange silver indicate 4,7 and 3 zeros;
i.e. a 47kΩ, 10% resistor.

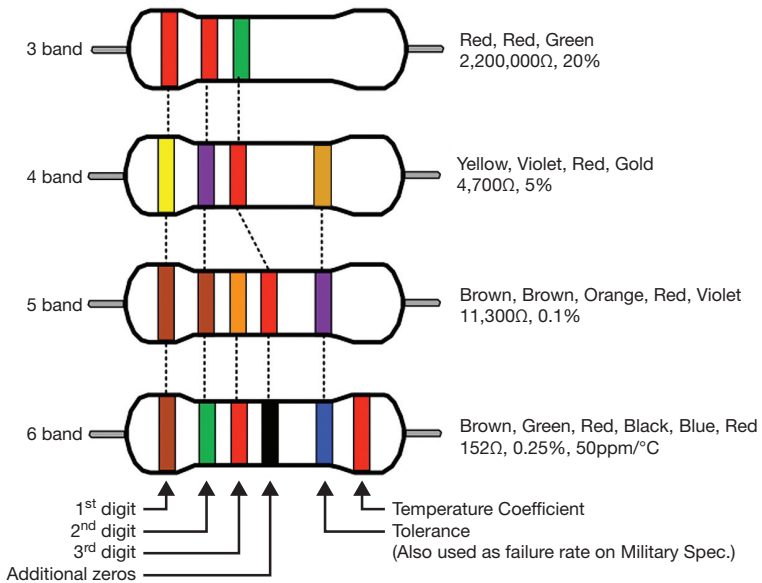

Figure 1: Resistor color code examples

Table 9: Standard resistor values

Standard resistance values for the 10 to 100 decade

0.1%			2%			0.1%			2%			0.1%			2%			0.1%			2%			0.1%			2%									
0.1%	0.25%	0.5%	1%	2%	5%	10%	1%	2%	5%	10%	1%	2%	5%	10%	1%	2%	5%	10%	1%	2%	5%	10%	1%	2%	5%	10%	1%	2%	5%	10%						
10.0	10.0	10.0	14.7	14.7	14.7	21.5	21.5	21.5	31.6	31.6	31.6	46.4	46.4	46.4	68.1	68.1	68.1	100	100	100	147	147	147	215	215	215	316	316	316	464	464	464	681	681	681	1000
10.1			14.9	14.9	14.9	21.8	21.8	21.8	32.0	32.0	32.0	47.0	47.0	47.0	69.0	69.0	69.0	101	101	101	149	149	149	218	218	218	320	320	320	470	470	470	690	690	690	1010
10.2	10.2	10.2	15.0	15.0	15.0	22.1	22.1	22.1	32.4	32.4	32.4	47.5	47.5	47.5	69.8	69.8	69.8	102	102	102	150	150	150	221	221	221	324	324	324	475	475	475	698	698	698	1020
10.4			15.2	15.2	15.2	22.3	22.3	22.3	32.8	32.8	32.8	48.1	48.1	48.1	70.6	70.6	70.6	104	104	104	152	152	152	223	223	223	328	328	328	481	481	481	706	706	706	1040
10.5	10.5	10.5	15.4	15.4	15.4	22.6	22.6	22.6	33.2	33.2	33.2	48.7	48.7	48.7	71.5	71.5	71.5	105	105	105	154	154	154	226	226	226	332	332	332	487	487	487	715	715	715	1050
10.6			15.6	15.6	15.6	22.9	22.9	22.9	33.6	33.6	33.6	49.3	49.3	49.3	72.3	72.3	72.3	106	106	106	156	156	156	229	229	229	336	336	336	493	493	493	723	723	723	1060
10.7	10.7	10.7	15.8	15.8	15.8	23.2	23.2	23.2	34.0	34.0	34.0	49.9	49.9	49.9	73.2	73.2	73.2	107	107	107	158	158	158	232	232	232	340	340	340	499	499	499	732	732	732	1070
10.9			16.0	16.0	16.0	23.4	23.4	23.4	34.4	34.4	34.4	50.5	50.5	50.5	74.1	74.1	74.1	109	109	109	160	160	160	234	234	234	344	344	344	505	505	505	741	741	741	1090
11.0	11.0	11.0	16.2	16.2	16.2	23.7	23.7	23.7	34.8	34.8	34.8	51.1	51.1	51.1	75.0	75.0	75.0	110	110	110	162	162	162	237	237	237	348	348	348	511	511	511	750	750	750	1100
11.1			16.4	16.4	16.4	24.0	24.0	24.0	35.2	35.2	35.2	51.7	51.7	51.7	75.9	75.9	75.9	111	111	111	164	164	164	240	240	240	352	352	352	517	517	517	759	759	759	1110
11.3	11.3	11.3	16.5	16.5	16.5	24.3	24.3	24.3	35.7	35.7	35.7	52.3	52.3	52.3	76.8	76.8	76.8	113	113	113	165	165	165	243	243	243	357	357	357	523	523	523	768	768	768	1130
11.4			16.7	16.7	16.7	24.6	24.6	24.6	36.1	36.1	36.1	53.0	53.0	53.0	77.7	77.7	77.7	114	114	114	167	167	167	246	246	246	361	361	361	530	530	530	777	777	777	1140
11.5	11.5	11.5	16.9	16.9	16.9	24.9	24.9	24.9	36.5	36.5	36.5	53.6	53.6	53.6	78.7	78.7	78.7	115	115	115	169	169	169	249	249	249	365	365	365	536	536	536	787	787	787	1150
11.7			17.2	17.2	17.2	25.2	25.2	25.2	37.0	37.0	37.0	54.2	54.2	54.2	79.6	79.6	79.6	117	117	117	172	172	172	252	252	252	370	370	370	542	542	542	796	796	796	1170
11.8	11.8	11.8	17.4	17.4	17.4	25.5	25.5	25.5	37.4	37.4	37.4	54.9	54.9	54.9	80.6	80.6	80.6	118	118	118	174	174	174	255	255	255	374	374	374	549	549	549	806	806	806	1180
12.0			17.6	17.6	17.6	25.8	25.8	25.8	37.9	37.9	37.9	55.6	55.6	55.6	81.6	81.6	81.6	120	120	120	176	176	176	258	258	258	379	379	379	556	556	556	816	816	816	1200
12.1	12.1	12.1	17.8	17.8	17.8	26.1	26.1	26.1	38.3	38.3	38.3	56.2	56.2	56.2	82.5	82.5	82.5	121	121	121	178	178	178	261	261	261	383	383	383	562	562	562	825	825	825	1210
12.3			18.0	18.0	18.0	26.4	26.4	26.4	38.8	38.8	38.8	56.9	56.9	56.9	83.5	83.5	83.5	123	123	123	180	180	180	264	264	264	388	388	388	569	569	569	835	835	835	1230
12.4	12.4	12.4	18.2	18.2	18.2	26.7	26.7	26.7	39.2	39.2	39.2	57.6	57.6	57.6	84.5	84.5	84.5	124	124	124	182	182	182	267	267	267	392	392	392	576	576	576	845	845	845	1240
12.6			18.4	18.4	18.4	27.1	27.1	27.1	39.7	39.7	39.7	58.3	58.3	58.3	85.6	85.6	85.6	126	126	126	184	184	184	271	271	271	397	397	397	583	583	583	856	856	856	1260
12.7	12.7	12.7	18.7	18.7	18.7	27.4	27.4	27.4	40.2	40.2	40.2	59.0	59.0	59.0	86.6	86.6	86.6	127	127	127	187	187	187	274	274	274	402	402	402	590	590	590	866	866	866	1270
12.9			18.9	18.9	18.9	27.7	27.7	27.7	40.7	40.7	40.7	59.7	59.7	59.7	87.6	87.6	87.6	129	129	129	189	189	189	277	277	277	407	407	407	597	597	597	876	876	876	1290
13.0	13.0	13.0	19.1	19.1	19.1	28.0	28.0	28.0	41.2	41.2	41.2	60.4	60.4	60.4	88.7	88.7	88.7	130	130	130	191	191	191	280	280	280	412	412	412	604	604	604	887	887	887	1300
13.2			19.3	19.3	19.3	28.4	28.4	28.4	41.7	41.7	41.7	61.2	61.2	61.2	89.8	89.8	89.8	132	132	132	193	193	193	284	284	284	417	417	417	612	612	612	898	898	898	1320
13.3	13.3	13.3	19.6	19.6	19.6	28.7	28.7	28.7	42.2	42.2	42.2	61.9	61.9	61.9	90.9	90.9	90.9	133	133	133	196	196	196	287	287	287	422	422	422	619	619	619	909	909	909	1330
13.5			19.8	19.8	19.8	29.1	29.1	29.1	42.6	42.6	42.6	62.6	62.6	62.6	92.0	92.0	92.0	135	135	135	198	198	198	291	291	291	426	426	426	626	626	626	920	920	920	1350
13.7	13.7	13.7	20.0	20.0	20.0	29.4	29.4	29.4	43.2	43.2	43.2	63.4	63.4	63.4	93.1	93.1	93.1	137	137	137	200	200	200	294	294	294	432	432	432	634	634	634	931	931	931	1370
13.8			20.3	20.3	20.3	29.8	29.8	29.8	43.7	43.7	43.7	64.2	64.2	64.2	94.2	94.2	94.2	138	138	138	203	203	203	298	298	298	437	437	437	642	642	642	942	942	942	1380
14.0	14.0	14.0	20.5	20.5	20.5	30.1	30.1	30.1	44.2	44.2	44.2	64.9	64.9	64.9	95.3	95.3	95.3	140	140	140	205	205	205	301	301	301	442	442	442	649	649	649	953	953	953	1400
14.2			20.8	20.8	20.8	30.5	30.5	30.5	44.8	44.8	44.8	65.7	65.7	65.7	96.5	96.5	96.5	142	142	142	208	208	208	305	305	305	448	448	448	657	657	657	965	965	965	1420
14.3	14.3	14.3	21.0	21.0	21.0	30.9	30.9	30.9	45.3	45.3	45.3	66.5	66.5	66.5	97.6	97.6	97.6	143	143	143	210	210	210	309	309	309	453	453	453	665	665	665	976	976	976	1430
14.5			21.3	21.3	21.3	31.2	31.2	31.2	45.9	45.9	45.9	67.3	67.3	67.3	98.8	98.8	98.8	145	145	145	213	213	213	312	312	312	459	459	459	673	673	673	988	988	988	1450

Practical capacitor model and specifications

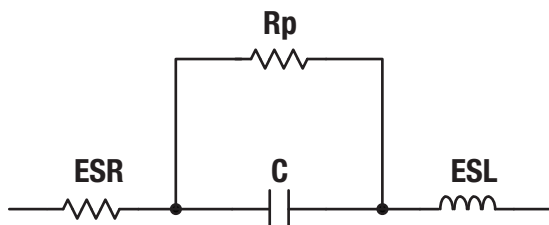

Figure 2: Model of a practical capacitor

Table 10: Capacitor specifications

Parameter	Description
C	The nominal value of the capacitance Table 12 lists standard capacitance values
ESR	Equivalent series resistance Ideally this is zero Ceramic capacitors have the best ESR (typically in milliohms). Tantalum Electrolytic have ESR in the hundreds of milliohms and Aluminum Electrolytic have ESR in the ohms
ESL	Equivalent series inductance Ideally this is zero ESL ranges from 100 pH to 10 nH
Rp	Rp is a parallel leakage resistance (or insulation resistance) Ideally this is infinite This can range from tens of megaohms for some electrolytic capacitors to tens of gihohms for ceramic
Voltage rating	The maximum voltage that can be applied to the capacitor Exceeding this rating damages the capacitor
Voltage coefficient	The change in capacitance with applied voltage in ppm/V A high-voltage coefficient can introduce distortion COG capacitors have the lowest coefficient The voltage coefficient is most important in applications that use capacitors in signal processing such as filtering
Temperature coefficient	The change in capacitance with across temperature in ppm/°C Ideally, the temperature coefficient is zero The maximum specified drift generally ranges from 10 to 100ppm/°C or greater depending on the capacitor type (See Table 11 for details)

Practical capacitors vs. frequency

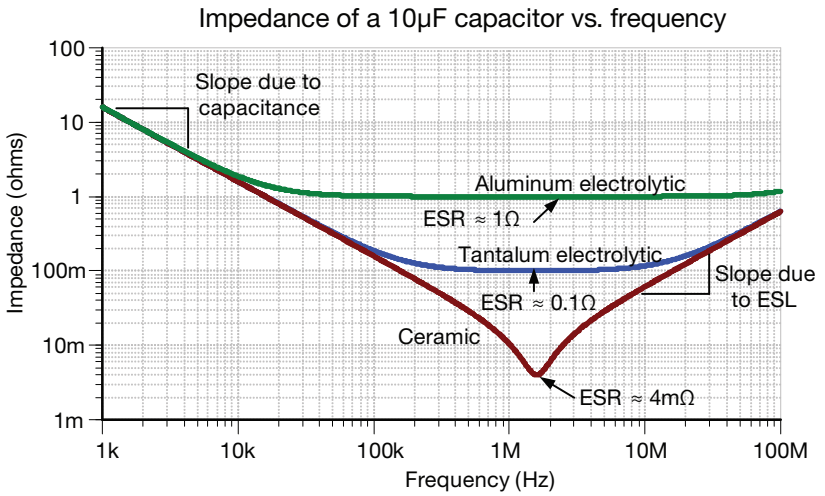

Figure 3: Effect of ESR and ESL on capacitor frequency response

Table 11: Capacitor type overview

Capacitor type	Description
COG/NPO (Type 1 ceramic)	<p>Use in signal path, filtering, low distortion, audio, and precision</p> <p>Limited capacitance range: 0.1 pF to 0.47 μF</p> <p>Lowest temperature coefficient: ± 30 ppm/$^{\circ}$C</p> <p>Low-voltage coefficient</p> <p>Minimal piezoelectric effect</p> <p>Good tolerance: $\pm 1\%$ to $\pm 10\%$</p> <p>Temperature range: -55°C to 125°C (150°C and higher)</p> <p>Voltage range may be limited for larger capacitance values</p>
X7R (Type 2 ceramic)	<p>Use for decoupling and other applications where accuracy and low distortion are not required</p> <p>X7R is an example of a type 2 ceramic capacitor</p> <p>See EIA capacitor tolerance table for details on other types</p> <p>Capacitance range: 10 pF to 47 μF</p> <p>Temperature coefficient: ± 833 ppm/$^{\circ}$C ($\pm 15\%$ across temp range)</p> <p>Substantial voltage coefficient</p> <p>Tolerance: $\pm 5\%$ to $-20\%/+80\%$</p> <p>Temperature range: -55°C to 125°C</p> <p>Voltage range may be limited for larger capacitance values</p>
Y5V (Type 2 ceramic)	<p>Use for decoupling and other applications where accuracy and low distortion are not required</p> <p>Y5V is an example of a type 2 ceramic capacitor</p> <p>See EIA capacitor tolerance table for details on other types</p> <p>Temperature coefficient: $-20\%/+80\%$ across temp range</p> <p>Temperature range: -30°C to 85°C</p> <p>Other characteristics are similar to X7R and other type 2 ceramic</p>
Aluminum oxide electrolytic	<p>Use for bulk decoupling and other applications where large capacitance is required</p> <p>Note that electrolytic capacitors are polarized and will be damaged, if a reverse polarity connection is made</p> <p>Capacitance range: 1 μF to 68,000 μF</p> <p>Temperature coefficient: ± 30 ppm/$^{\circ}$C</p> <p>Substantial voltage coefficient Tolerance: $\pm 20\%$</p> <p>Temperature range: -55°C to 125°C (150°C and higher)</p> <p>Higher ESR than other types</p>
Tantalum electrolytic	<p>Capacitance range: 1 μF to 150 μF</p> <p>Similar to aluminum oxide but smaller size</p>
Polypropylene film	<p>Capacitance range: 100 pF to 10 μF</p> <p>Very low voltage coefficient (low distortion)</p> <p>Higher cost than other types</p> <p>Larger size per capacitance than other types</p> <p>Temperature coefficient: 2% across temp range</p> <p>Temperature range: -55°C to 100°C</p>

Table 12: Standard capacitance table

Standard capacitance table												
1	1.1	1.2	1.3	1.5	1.6	1.8	2	2.2	2.4	2.7	3	
3.3	3.6	3.9	4.3	4.7	5.1	5.6	6.2	6.8	7.5	8.2	9.1	

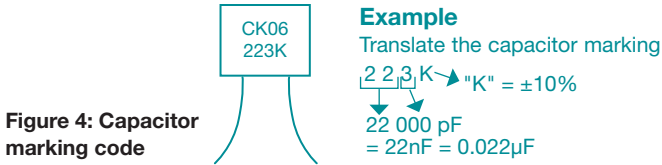

Table 13: Ceramic capacitor tolerance markings

Code	Tolerance	Code	Tolerance
B	± 0.1 pF	J	± 5%
C	± 0.25 pF	K	± 10%
D	± 0.5 pF	M	± 20%
F	± 1%	Z	+ 80%, -20%
G	± 2%		

Table 14: EIA capacitor tolerance markings (Type 2 capacitors)

First letter symbol	Low temp limit	Second number symbol	High temp limit	Second letter symbol	Max. capacitance change over temperature rating
Z	+10°C	2	+45°C	A	±1.0%
Y	-30°C	4	+65°C	B	±1.5%
X	-55°C	5	+85°C	C	±2.2%
		6	+105°C	D	±3.3%
		7	+125°C	E	±4.7%
				F	±7.5%
				P	±10.0%
				R	±15.0%
				S	±22.0%
				T	±22% ~ 33%
				U	±22% ~ 56%
				V	±22% ~ 82%

Example
 X7R: -55°C to +125°C, ±15.0%

Diodes and LEDs

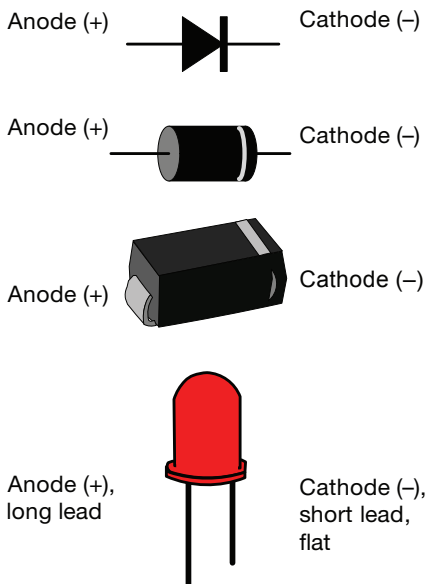

Figure 5: Diode and LED pin names

Table 15: LED forward voltage drop by color

Color	Wavelength (nm)	Voltage (approximate range)
Infrared	940-850	1.4 to 1.7
Red	660-620	1.7 to 1.9
Orange / Yellow	620-605	2 to 2.2
Green	570-525	2.1 to 3.0
Blue/White	470-430	3.4 to 3.8

Note: The voltages given are approximate, and are intended to show the general trend for forward voltage drop of LED diodes. Consult the manufacturer's data sheet for more precise values.

Bipolar junction transistors (BJT)

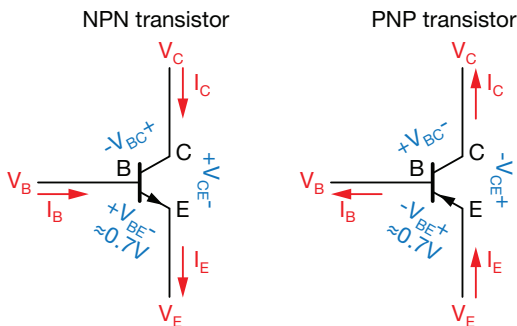

Figure 6: Bipolar transistors

$$I_C = I_B \cdot \beta$$

$$I_C = I_B + I_E$$

$$V_{BE} \approx 0.7V$$

V_{BC} is reversed biased

$$V_{CE} \approx V_{BC} + V_{BE}$$

(1) Current gain

(2) Current law for bipolar transistors

(3) Voltage base to emitter is forward bias for normal operation. Approximately 0.7V.

(4) Voltage base to collector is reverse bias for normal operation

(5) Collector to emitter voltage

Where

B, E, C = base, emitter, and collector

I_B , I_E , I_C = base, emitter, and collector current

$\beta = h_{fe}$ = current gain

V_{CE} = collector to emitter voltage

V_{BC} = base to collector voltage

V_{BE} = base to emitter voltage

Junction field effect transistors (JFET)

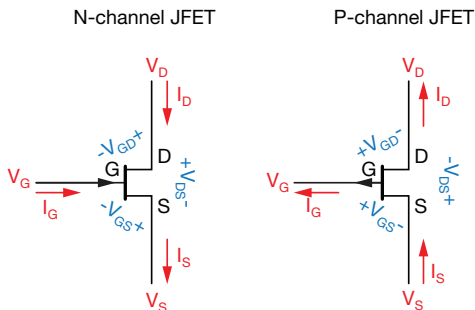

Figure 7: JFET transistors

$$I_G \approx 0V$$

$$I_D = I_S$$

$$I_D = \frac{2I_{DSS}}{V_P^2} \left(V_{GS} - V_P - \frac{V_{DS}}{2} \right) V_{DS}$$

$$I_D = I_{DSS} \left(1 - \frac{V_{GS}}{V_P} \right)^2$$

(6) Gate to source reverse biased for normal operation

(7) Drain current equal to source current

(8) Drain current in linear region

(9) Drain current in saturation region

Where

G, D, S = gate, drain, and source

I_{DSS} = saturation current at zero gate to source voltage

V_P = pinch off voltage where the drain-to-source current stops

$I_D = I_S$ = drain current, source current. These will be equal.

V_{GS} = gate to source voltage

V_{DS} = drain to source voltage

Junction field effect transistors (JFET)

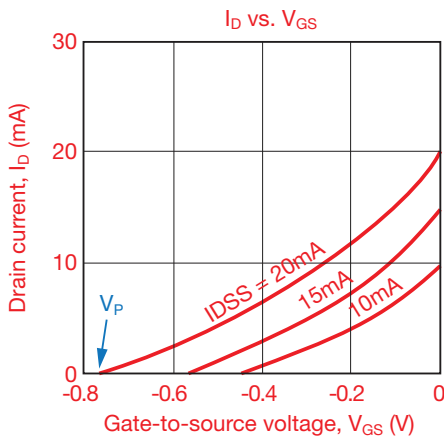
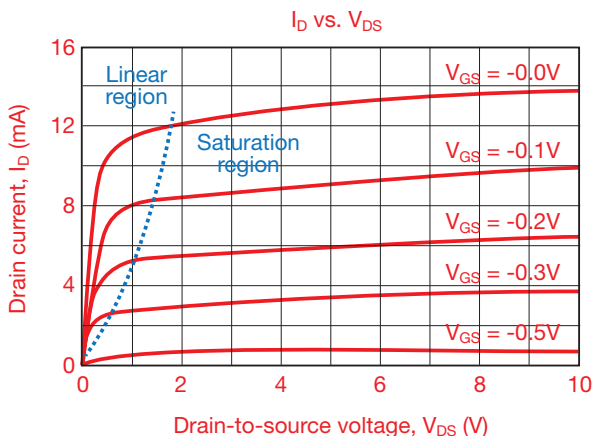
Figure 8: N-channel JFET characteristic curve I_D vs V_{GS} Figure 9: N-channel JFET characteristic curve I_D vs V_{GS}

- The maximum gate-to-source voltage is 0V for an N-channel JFET. Greater than 0V will forward bias the gate-to-source junction and cause abnormal operation.
- The P-channel FET has similar characteristic curves but the polarity is opposite.

Metal oxide semiconductor field effect transistor (MOSFET)

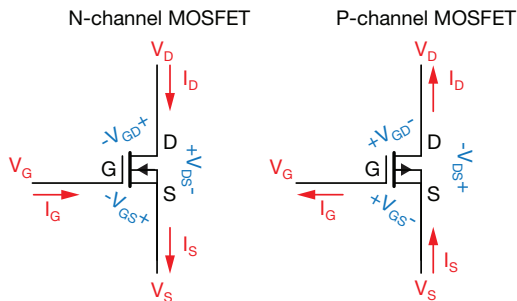

Figure 10: MOSFET transistors

$$I_G \approx 0A$$

(10) Gate is insulated so that input current is negligible

$$I_D = I_S$$

(11) Drain current equal to source current

$$I_D = \mu_n C_{OX} \frac{W}{L} \left((V_{GS} - V_{TH}) V_{DS} - \frac{V_{DS}^2}{2} \right)$$

(12) Drain current in linear region (triode)

$$I_D = \frac{\mu_n C_{OX}}{2} \frac{W}{L} (V_{GS} - V_{TH})^2 (1 + \lambda (V_{DS} - V_{DSsat}))$$

(13) Drain current in saturation region

Where

G, D, S = gate, drain, and source

μ_n = charge-carrier effective mobility

C_{OX} = capacitance of oxide

W, L = width and length of gate

V_{GS} = gate to source voltage

V_{DS} = drain to source voltage

V_{TH} = threshold voltage

λ = channel length modulation

Metal oxide semiconductor field effect transistor (MOSFET)

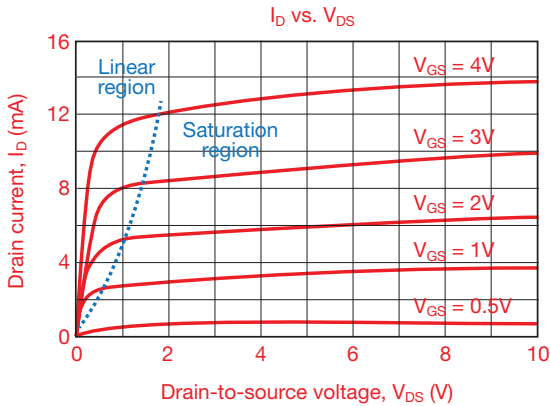
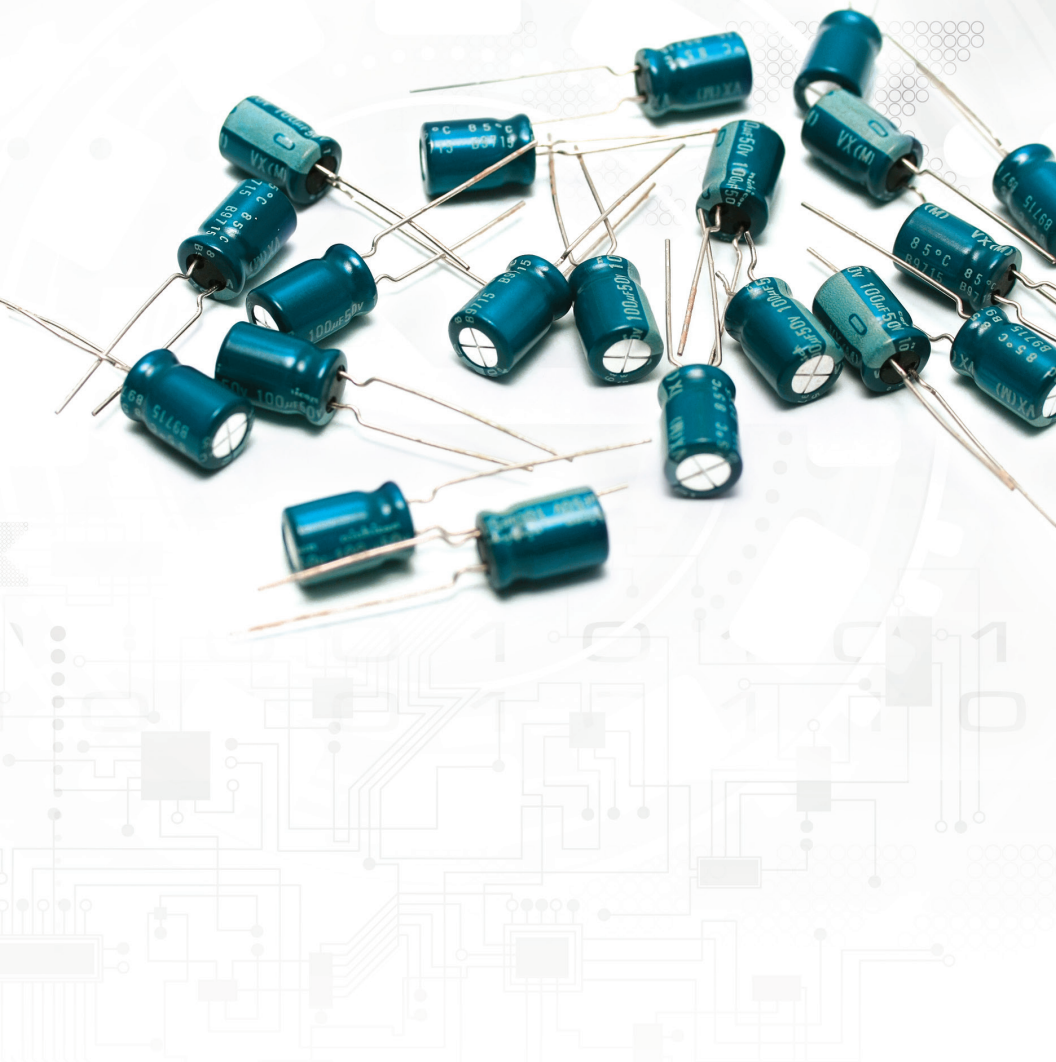

Figure 11: N-channel MOSFET characteristic curve, I_D vs. V_{DS}

- The parameters, such as μ_n , C_{OX} , W , and L , may not be given in discrete MOSFET data sheets.
- The P-channel FET has similar characteristic curves but the polarity is opposite.

Analog

- Resistor equations •
- Power equations •
- Capacitor equations (series, parallel, charge, energy) •
- Inductor equations (series, parallel, energy) •
- Capacitor charge and discharge •
- RMS and mean voltage definition •
- RMS for common signals •
- Logarithm laws •
- dB definitions •
- Pole and zero definition with examples •



Resistor equations

$$R_T = R_1 + R_2 + \dots + R_N \tag{14} \text{ Series resistors}$$

$$R_T = \frac{R_1 \cdot R_2}{R_1 + R_2} \tag{15} \text{ Two parallel resistors}$$

$$R_T = \frac{1}{\frac{1}{R_1} + \frac{1}{R_2} + \dots + \frac{1}{R_N}} \tag{16} \text{ Parallel resistors}$$

Analog

Where

R_T = equivalent total resistance

$R_1, R_2, R_3, \dots, R_N$ = component resistors

Ohm's law and voltage divider equation

$$V = I \cdot R \tag{17} \text{ Ohm's law}$$

$$V_{OUT} = \left(\frac{R_2}{R_1 + R_2} \right) \cdot V_{SUP} \tag{18} \text{ Voltage divider equation}$$

Where

V = voltage in volts (V)

I = current in amps (A)

R = resistance in ohms (Ω)

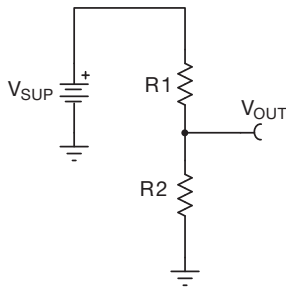

Figure 12: Voltage divider

Power equations

$$P = I \cdot V \quad (19) \text{ Power equation for voltage and current}$$

$$P = \frac{V^2}{R} \quad (20) \text{ Power equation for voltage and resistance}$$

$$P = I^2 \cdot R \quad (21) \text{ Power equation for current and resistance}$$

Where

P = power in watts (W)

V = voltage in volts (V)

I = current in amps (A)

R = resistance in ohms (Ω)

$$P = \frac{1}{2} \cdot V_p \cdot I_p \cdot \cos \theta \quad (22) \text{ AC power equation}$$

Where

P = average power in watts (W) for sinusoidal signals

V_p = peak voltage in volts (V)

I_p = peak current in amps (A)

θ = phase angle between the voltage and current sine waves

Capacitor equations

$$C_t = \frac{1}{\frac{1}{C_1} + \frac{1}{C_2} + \dots + \frac{1}{C_N}} \quad (23) \text{ Series capacitors}$$

$$C_t = \frac{C_1 C_2}{C_1 + C_2} \quad (24) \text{ Two series capacitors}$$

$$C_t = C_1 + C_2 + \dots + C_N \quad (25) \text{ Parallel capacitors}$$

Where

C_t = equivalent total capacitance

$C_1, C_2, C_3 \dots C_N$ = component capacitors

$$Q = CV \quad (26) \text{ Charge storage}$$

$$Q = It \quad (27) \text{ Charge defined}$$

Where

Q = charge in coulombs (C)

C = capacitance in farads (F)

V = voltage in volts (V)

I = current in amps (A)

t = time in seconds (s)

$$i = C \frac{dv}{dt} \quad (28) \text{ Instantaneous current through a capacitor}$$

Where

i = instantaneous current through the capacitor

C = capacitance in farads (F)

$\frac{dv}{dt}$ = the instantaneous rate of voltage change

$$E = \frac{1}{2} CV^2 \quad (29) \text{ Energy stored in a capacitor}$$

Where

E = energy stored in a capacitor in joules (J)

V = voltage in volts

C = capacitance in farads (F)

Inductor equations

$$L_t = L_1 + L_2 + \dots + L_N \quad (30) \text{ Series inductors}$$

$$L_t = \frac{1}{\frac{1}{L_1} + \frac{1}{L_2} + \dots + \frac{1}{L_N}} \quad (31) \text{ Parallel inductors}$$

$$L_t = \frac{L_1 L_2}{L_1 + L_2} \quad (32) \text{ Two parallel inductors}$$

Where

L_t = equivalent total inductance

$L_1, L_2, L_3 \dots L_N$ = component inductance

$$v = L \frac{di}{dt} \quad (33) \text{ Instantaneous voltage across an inductor}$$

Where

v = instantaneous voltage across the inductor

L = inductance in henries (H)

$\frac{di}{dt}$ = instantaneous rate of current change

$$E = \frac{1}{2} L I^2 \quad (34) \text{ Energy stored in an inductor}$$

Where

E = energy stored in an inductor in joules (J)

I = current in amps

L = inductance in henries (H)

Equation for charging an RC circuit

$$V_C = V_S \left[1 - e^{\left(\frac{-t}{\tau} \right)} \right] \quad (35) \text{ General relationship}$$

Where

V_C = voltage across the capacitor at any instant in time (t)

V_S = the source voltage charging the RC circuit

t = time in seconds

τ = RC, the time constant for charging and discharging capacitors

Graphing equation 35 produces the capacitor charging curve below. Note that the capacitor is 99.3% charged at five time constants. It is common practice to consider this *fully charged*.

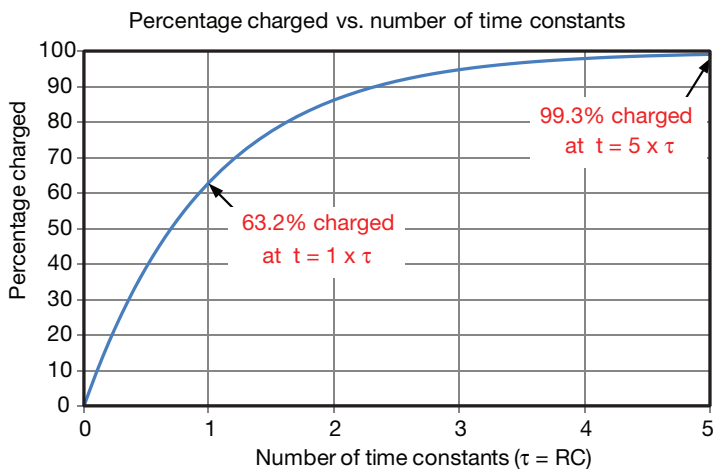

Figure 13: RC charge curve

Equation for discharging an RC circuit

$$V_C = V_i \left[e^{\left(\frac{-t}{\tau}\right)} \right] \quad (36) \text{ General Relationship}$$

Where

V_C = voltage across the capacitor at any instant in time (t)

V_i = the initial voltage of the capacitor at $t = 0s$

t = time in seconds

τ = RC, the time constant for charging and discharging capacitors

Graphing equation 36 produces the capacitor discharge curve below. Note that the capacitor is discharged to 0.7% at five time constants. It is common practice to consider this *fully discharged*.

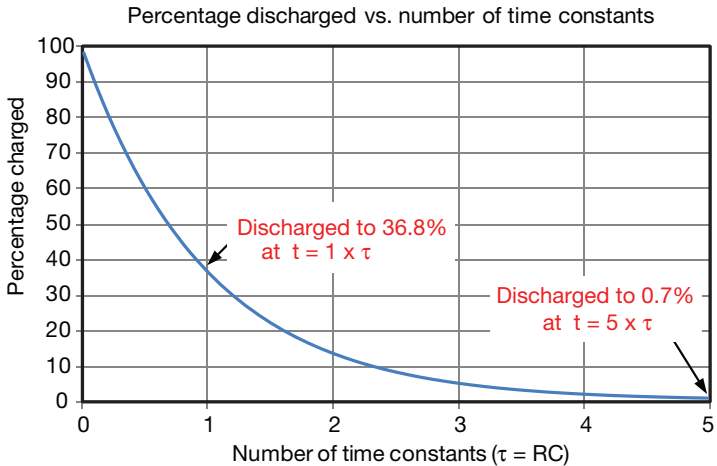

Figure 14: RC discharge curve

Capacitor with constant current source

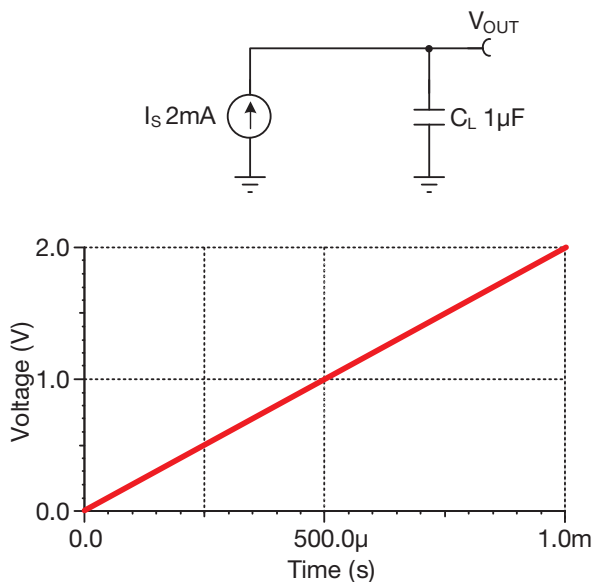

Figure 15: Capacitor with constant current source

$$dv = \frac{i}{C} dt \quad (37) \text{ General equation for capacitor voltage current}$$

$$V_{OUT} = \frac{I_S}{C_L} t \quad (38) \text{ For constant current}$$

Where

I_S = constant current source in amps (A)

V_{OUT} = voltage developed across the capacitor in volts (V)

C_L = load capacitance in farads (F)

t = time in seconds (s)

RMS and mean voltage

RMS voltage

$$V_{\text{RMS}} = \sqrt{\frac{1}{(T_2 - T_1)} \int_{T_1}^{T_2} [V(t)]^2 dt} \quad (39) \text{ General relationship}$$

Where

$V(t)$ = continuous function of time

t = time in seconds

$T_1 \leq t \leq T_2$ = the time interval that the function is defined over

Mean voltage

$$V_{\text{MEAN}} = \frac{1}{(T_2 - T_1)} \int_{T_1}^{T_2} V(t) dt \quad (40) \text{ General relationship}$$

Where

$V(t)$ = continuous function of time

t = time in seconds

$T_1 \leq t \leq T_2$ = the time interval that the function is defined over

$$V_{\text{RMS}} = \frac{V_{\text{PEAK}}}{\sqrt{2}} \quad (41) \text{ RMS for full wave rectified sine wave}$$

$$V_{\text{MEAN}} = \frac{2 \times V_{\text{PEAK}}}{\pi} \quad (42) \text{ Mean for full wave rectified sine wave}$$

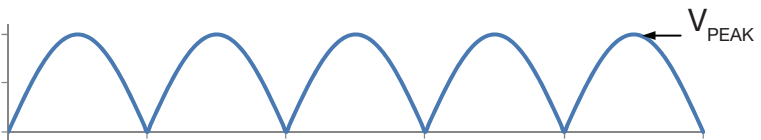

Figure 16: Full wave rectified sine wave

RMS voltage and mean voltage (cont.)

$$V_{\text{RMS}} = V_{\text{PEAK}} \sqrt{\frac{\tau}{2T}}$$

(43) RMS for a half-wave rectified sine wave

$$V_{\text{MEAN}} = \frac{2 \cdot V_{\text{PEAK}}}{\pi} \left(\frac{\tau}{T} \right)$$

(44) Mean for a half-wave rectified sine wave

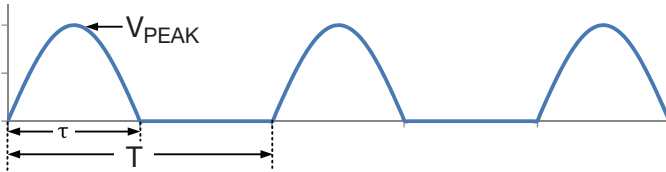

Figure 17: Half-wave rectified sine wave

$$V_{\text{RMS}} = V_{\text{PEAK}} \sqrt{\frac{\tau}{T}}$$

(45) RMS for a square wave

$$V_{\text{MEAN}} = V_{\text{PEAK}} \left(\frac{\tau}{T} \right)$$

(46) Mean for a square wave

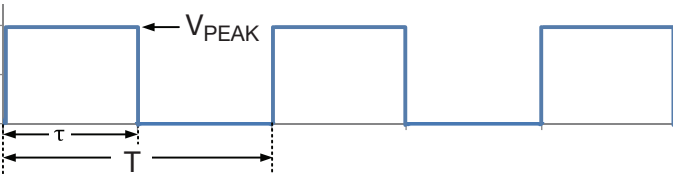

Figure 18: Square wave

RMS voltage and mean voltage (cont.)

$$V_{\text{RMS}} = \sqrt{\left(\frac{V_a^2 + V_a \cdot V_b + V_b^2}{3}\right)\left(\frac{\tau}{T}\right)} \quad (47) \text{ RMS for a trapezoid}$$

$$V_{\text{MEAN}} = \frac{\tau}{2T}(V_a + V_b) \quad (48) \text{ Mean for a trapezoid}$$

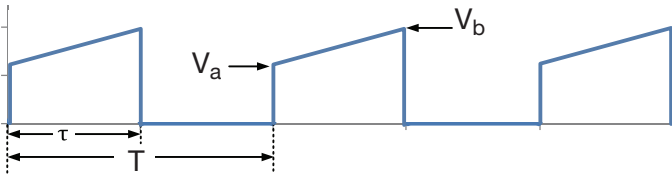

Figure 19: Trapezoidal wave

$$V_{\text{RMS}} = V_{\text{PEAK}} \sqrt{\frac{\tau}{3T}} \quad (49) \text{ RMS for a triangle wave}$$

$$V_{\text{MEAN}} = \frac{\tau}{2T} V_{\text{PEAK}} \quad (50) \text{ Mean for a triangle wave}$$

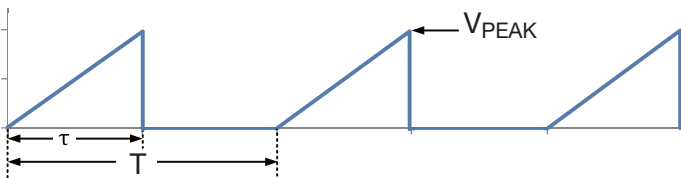

Figure 20: Triangle wave

Logarithmic mathematical definitions

$$\log\left(\frac{A}{B}\right) = \log(A) - \log(B) \quad (51) \text{ Log of dividend}$$

$$\log(AB) = \log(A) + \log(B) \quad (52) \text{ Log of product}$$

$$\log(A^x) = x \log(A) \quad (53) \text{ Log of exponent}$$

$$\log_b(X) = \frac{\log_a(X)}{\log_a(b)} \quad (54) \text{ Changing the base of log function}$$

$$\log_2(X) = \frac{\log_{10}(X)}{\log_{10}(2)} \quad (55) \text{ Example changing to log base 2}$$

$$\ln(X) = \log_e(X) \quad (56) \text{ Natural log is log base e}$$

$$e = 2.718282 \quad (57) \text{ Exponential function to 6 digits}$$

Alternative notations

$$\exp(x) = e^x \quad (58) \text{ Different notation for exponential function}$$

$$3.54E - 2 = 3.54 \times 10^{-2} \quad (59) \text{ Different notation for scientific notation, sometimes confused with exponential function}$$

dB definitions

Bode plot basics

The frequency response for the magnitude or gain plot is the change in voltage gain as frequency changes. This change is specified on a Bode plot, a plot of frequency versus voltage gain in dB (decibels). Bode plots are usually plotted as semi-log plots with frequency on the x-axis, log scale, and gain on the y-axis, linear scale. The other half of the frequency response is the phase shift versus frequency and is plotted as frequency versus degrees phase shift. Phase plots are usually plotted as semi-log plots with frequency on the x-axis, log scale, and phase shift on the y-axis, linear scale.

Definitions

$$\text{Voltage gain (dB)} = 20 \log \left(\frac{V_{\text{OUT}}}{V_{\text{IN}}} \right) \quad (60) \text{ Voltage gain in decibels}$$

$$\text{Power gain (dB)} = 10 \log \left(\frac{P_{\text{OUT}}}{P_{\text{IN}}} \right) \quad (61) \text{ Power gain in decibels}$$

$$\text{Power measured (dBm)} = 10 \log \left(\frac{\text{Power measured (W)}}{1 \text{ mW}} \right) \quad (62) \text{ Used for input or output power}$$

A (V/V)	A (dB)
0.001	-60
0.01	-40
0.1	-20
1	0
10	20
100	40
1,000	60
10,000	80
100,000	100
1,000,000	120
10,000,000	140

Table 16: Examples of common gain values and dB equivalent

Roll-off rate is the decrease in gain with frequency

Decade is a tenfold increase or decrease in frequency (from 10 Hz to 100 Hz is one decade)

Octave is the doubling or halving of frequency (from 10 Hz to 20 Hz is one octave)

Log scale

Figure 21 illustrates a method to graphically determine values on a logarithmic axis that are not directly on an axis grid line.

1. Given $L = 1\text{cm}$; $D = 2\text{cm}$, measured with a ruler
2. $L/D = \log_{10}(f_p)$
3. $f_p = 10^{(L/D)} = 10^{(1\text{cm}/2\text{cm})} = 3.16$
4. Adjust for the decade range (for this example, $f_p = 31.6\text{ Hz}$)

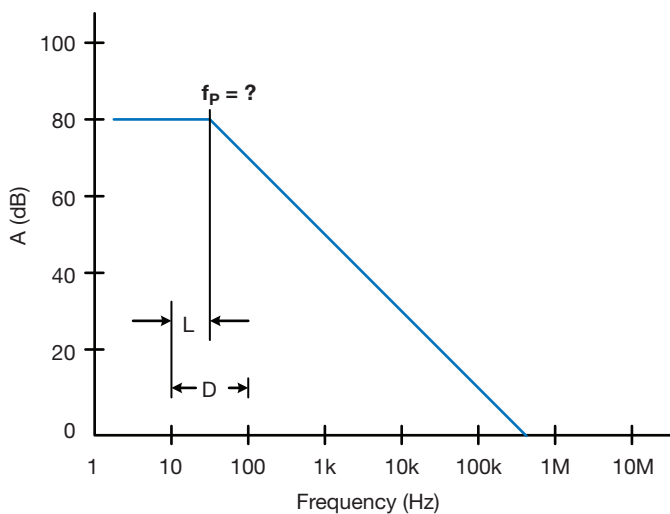

Figure 21: Finding values on logarithmic axis not directly on a grid line

Time to phase shift

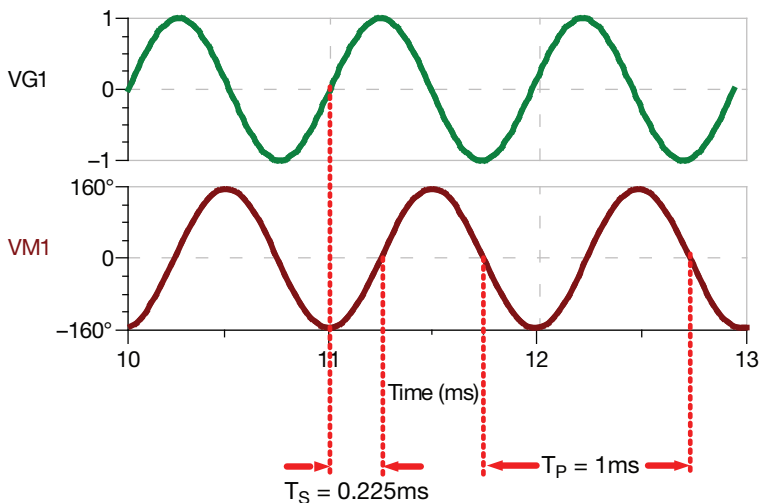

Figure 22: Time to phase shift

$$\theta = \frac{T_S}{T_P} \times 360^\circ$$

(63) Phase shift from time

Where

 T_S = time shift from input to output signal T_P = period of signal θ = phase shift of the signal from input to output

Example

Calculate the phase shift in degrees for Figure 24.

Answer

$$\theta = \frac{T_S}{T_P} \cdot 360^\circ = \left(\frac{0.225 \text{ ms}}{1 \text{ ms}} \right) \cdot 360^\circ = 81^\circ$$

Bode plots: Poles

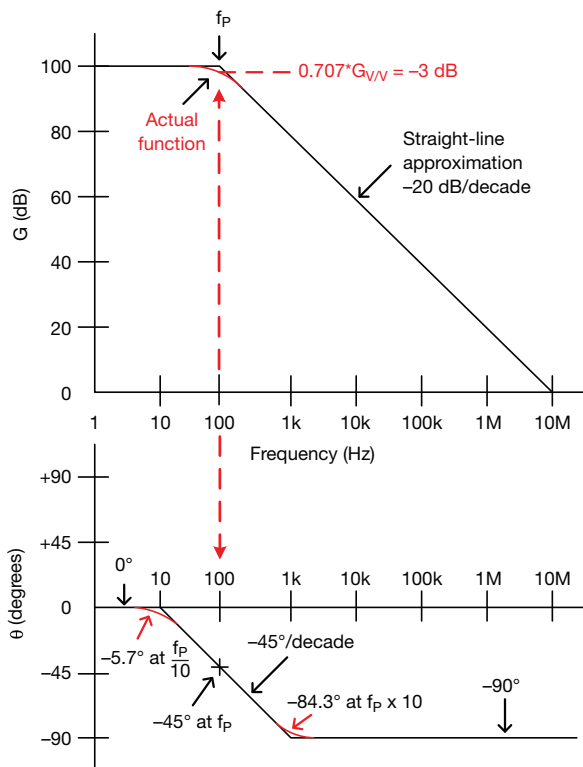

Figure 23: Pole gain and phase

Where

Pole location = f_p (cutoff freq)

Magnitude ($f < f_p$) = G_{DC} (for example, 100 dB)

Magnitude ($f = f_p$) = -3 dB

Magnitude ($f > f_p$) = -20 dB/decade

Phase ($f = f_p$) = -45°

Phase ($0.1 f_p < f < 10 f_p$) = -45° /decade

Phase ($f > 10 f_p$) = -90°

Phase ($f < 0.1 f_p$) = 0°

Pole (equations)

$$G_V = \frac{V_{OUT}}{V_{IN}} = \frac{G_{DC}}{j\left(\frac{f}{f_P}\right) + 1} \quad (64) \text{ As a complex number}$$

$$G_V = \frac{V_{OUT}}{V_{IN}} = \frac{G_{DC}}{\sqrt{\left(\frac{f}{f_P}\right)^2 + 1}} \quad (65) \text{ Magnitude}$$

$$\theta = -\tan^{-1}\left(\frac{f}{f_P}\right) \quad (66) \text{ Phase shift}$$

$$G_{dB} = 20 \text{ Log}(G_V) \quad (67) \text{ Magnitude in dB}$$

Where

G_V = voltage gain in V/V

G_{dB} = voltage gain in decibels

G_{DC} = the dc or low frequency voltage gain

f = frequency in Hz

f_P = frequency at which the pole occurs

θ = phase shift of the signal from input to output

j = indicates imaginary number or $\sqrt{-1}$

Bode plots (zeros)

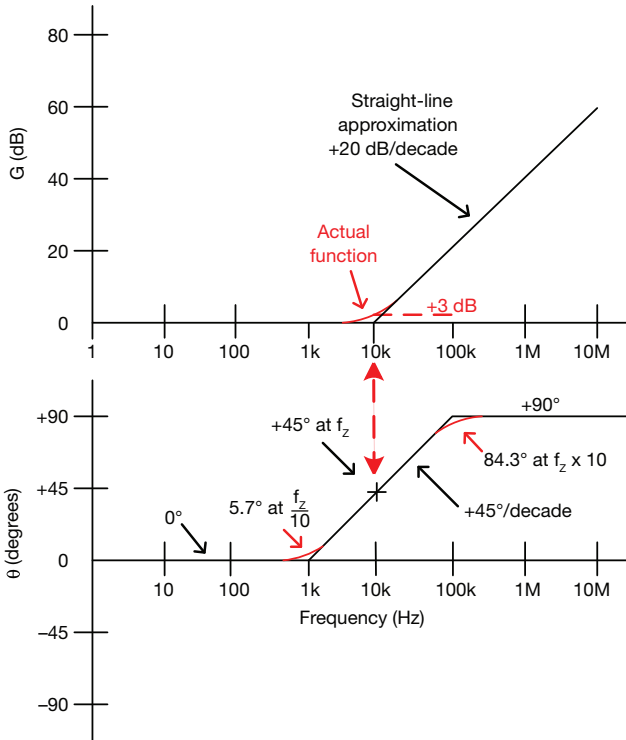

Figure 24: Zero gain and phase

Where

Zero location = f_z Magnitude ($f < f_z$) = 0 dBMagnitude ($f = f_z$) = +3 dBMagnitude ($f > f_z$) = +20 dB/decadePhase ($f = f_z$) = $+45^\circ$ Phase ($0.1 f_z < f < 10 f_z$) = $+45^\circ/\text{decade}$ Phase ($f > 10 f_z$) = $+90^\circ$ Phase ($f < 0.1 f_z$) = 0°

Zero (equations)

$$G_V = \frac{V_{OUT}}{V_{IN}} = G_{DC} \left[j \left(\frac{f}{f_Z} \right) + 1 \right] \quad (68) \text{ As a complex number}$$

$$G_V = \frac{V_{OUT}}{V_{IN}} = G_{DC} \sqrt{\left(\frac{f}{f_Z} \right)^2 + 1} \quad (69) \text{ Magnitude}$$

$$\theta = \tan^{-1} \left(\frac{f}{f_Z} \right) \quad (70) \text{ Phase shift}$$

$$G_{dB} = 20 \text{ Log}(G_V) \quad (71) \text{ Magnitude in dB}$$

Where

G_V = voltage gain in V/V

G_{dB} = voltage gain in decibels

G_{DC} = the dc or low frequency voltage gain

f = frequency in Hz

f_Z = frequency at which the zero occurs

θ = phase shift of the signal from input to output

j = indicates imaginary number or $\sqrt{-1}$

Amplifier

- Calculating amplifier offset •
- Op amp bandwidth •
- Full power bandwidth •
- Large signal step response •
- Settling time •
- Noise equations •
- Stability equations •
- Instrumentation amplifiers •
- Power calculations •
- Electrical overstress (EOS) •

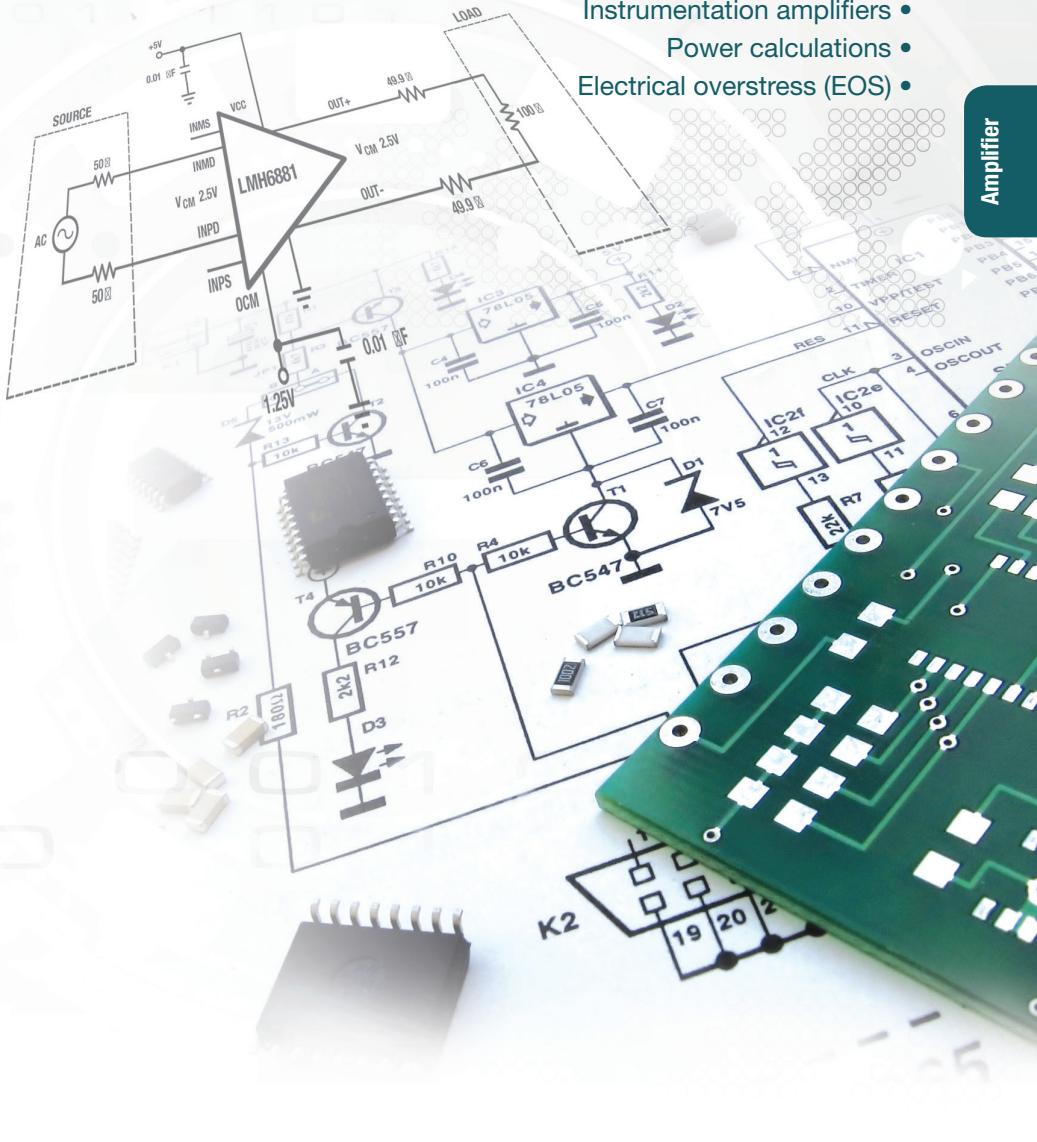

Amplifier

Basic op amp configurations

$$G_{CL} = 1$$

(72) Gain for buffer configuration

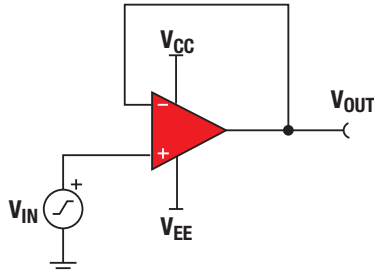

Figure 25: Buffer configuration

$$G_{CL} = \frac{R_f}{R_1} + 1$$

(73) Gain for non-inverting configuration

Z_{in} = Op amp input impedance

(74) Input impedance. See data sheet for value, but typically greater than 100MΩ to 100TΩ.

$$V_{cm} = V_{IN}$$

(75) The common mode voltage is equal to the input signal. Check for common mode limitations.

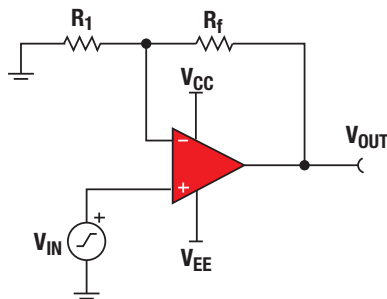

Figure 26: Non-inverting configuration

Basic op amp configurations (cont.)

$G_{CL} = -\frac{R_f}{R_1}$ (76) Gain for inverting configuration

$Z_{in} = R_1$ (77) Input impedance. Low compared to the non-inverting configuration.

$V_{cm} = 0V$ (78) The common mode voltage held constant at 0V so the common mode range and CMRR is not a concern

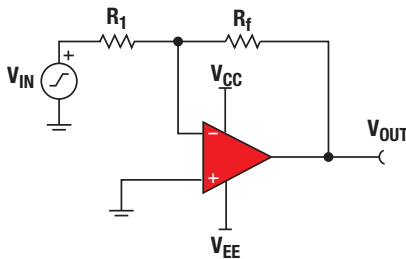

Figure 27: Inverting configuration

$V_{OUT} = -R_f \left(\frac{V_1}{R_1} + \frac{V_2}{R_2} + \dots + \frac{V_N}{R_N} \right)$ (79) Transfer function for inverting summing amplifier

$V_{OUT} = -\frac{R_f}{R_1} (V_1 + V_2 + \dots + V_N)$ (80) Transfer function for inverting summing amplifier, assuming $R_1 = R_2 = \dots = R_N$

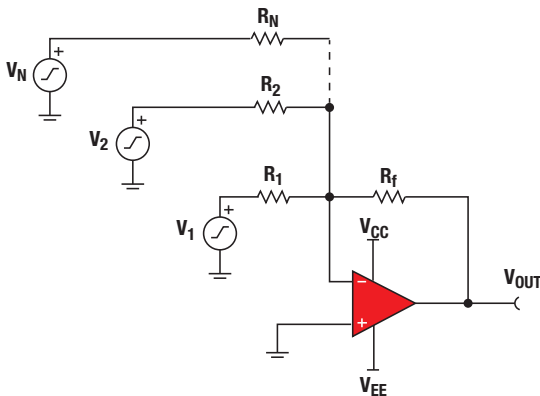

Figure 28: Inverting summing configuration

Basic op amp configurations (cont.)

$$V_{OUT} = \left(\frac{R_f}{R_{in}} + 1 \right) \left[\frac{V_1}{N} + \frac{V_2}{N} + \dots + \frac{V_N}{N} \right]$$

(81) Transfer function for noninverting summing amplifier for equal input resistors

Where

$$R_1 = R_2 = \dots = R_N$$

N = number of input resistors

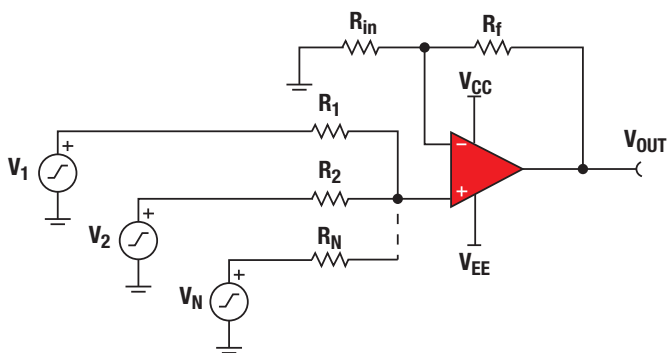

Figure 29: Non-inverting summing configuration

Simple non-inverting amp with C_f filter

$G_{LF} = \frac{R_f}{R_1} + 1$ (82) Gain for non-inverting configuration for $f < f_C$

$G_{HF} = 1$ (83) Gain for non-inverting configuration for $f \gg f_C$

$f_C = \frac{1}{2\pi R_f C_f}$ (84) Cut off frequency for non-inverting configuration

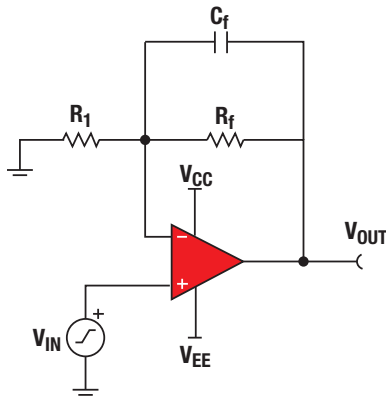

Figure 30: Non-inverting amplifier with C_f filter

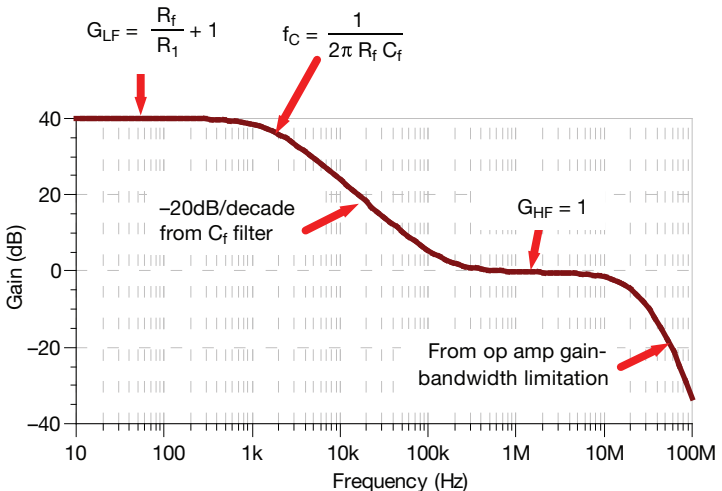

Figure 31: Frequency response for non-inverting op amp with C_f filter

Simple inverting amp with C_f filter

$$G_{LF} = -\frac{R_f}{R_1} \quad (85) \text{ Gain for inverting configuration for } f < f_c$$

$$G_{HF} = -20\text{dB/decade after } f_c \text{ until op amp bandwidth limitation} \quad (86) \text{ Gain for inverting configuration for } f > f_c$$

$$f_c = \frac{1}{2\pi R_f C_f} \quad (87) \text{ Cutoff frequency for inverting configuration}$$

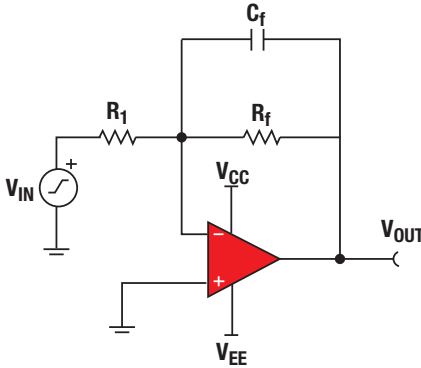

Figure 32: Inverting amplifier with C_f filter

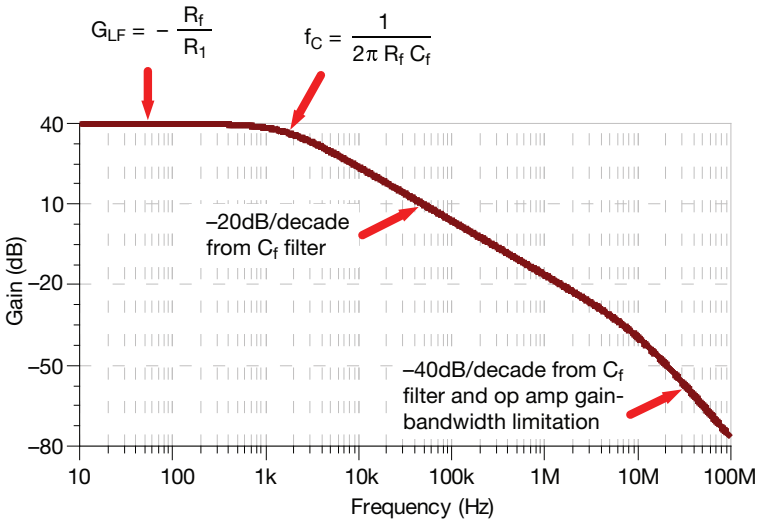

Figure 33: Frequency response for inverting op amp with C_f filter

Differential filter cutoff

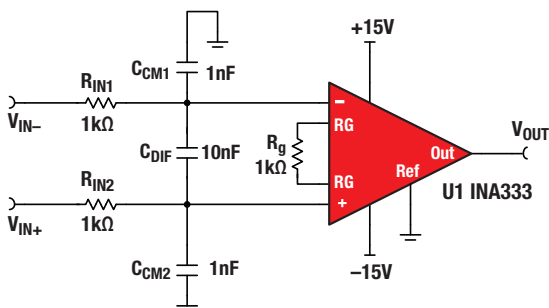

Figure 34: Input filter for instrumentation amplifier

Select $C_{DIF} \geq 10C_{CM1}$

(88) Differential capacitor is sized 10 times the common-mode capacitor

$R_{IN1} = R_{IN2}$

(89) Input resistors must be equal

$C_{CM1} = C_{CM2}$

(90) Common-mode capacitors must be equal

$$f_{CM} = \frac{1}{2\pi R_{IN1} C_{CM1}}$$

(91) Common-mode filter cutoff

$$f_{DIF} = \frac{1}{2\pi(2R_{IN1})\left(C_{DIF} + \frac{1}{2}C_{CM1}\right)}$$

(92) Differential filter cutoff

Where

f_{DIF} = differential cutoff frequency

f_{CM} = common-mode cutoff frequency

R_{IN} = input resistance

C_{CM} = common-mode filter capacitance

C_{DIF} = differential filter capacitance

Note: Selecting $C_{DIF} \geq 10 C_{CM}$ sets the differential mode cutoff frequency about 20 times lower than the common-mode cutoff frequency. This prevents common-mode noise from being converted into differential noise due to component tolerances.

Calculating amplifier offset voltage

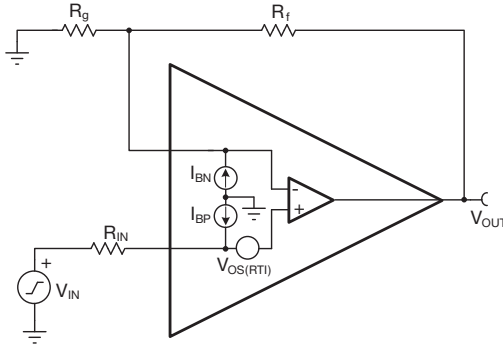

Figure 35: Op amp bias current and offset calculations

$$R_{eq} = \frac{R_f \cdot R_g}{R_f + R_g} \quad (93) \text{ Equivalent feedback resistance}$$

$$V_{OS(IBN)} = I_{BN} \cdot R_{eq} \quad (94) \text{ Offset RTI from } I_{BN} \text{ flowing into feedback}$$

$$V_{OS(IBP)} = I_{BP} \cdot R_{IN} \quad (95) \text{ Offset RTI from } I_{BP} \text{ flowing into source impedance}$$

$$V_{OS(\text{total worst})} = \pm V_{OS(\text{Amp})} \pm V_{OS(IBN)} \pm V_{OS(IBP)} \quad (96) \text{ Directly adding the offset components. Conservative estimate.}$$

$$V_{OS(\text{total stat})} = \sqrt{V_{OS(\text{Amp})}^2 + V_{OS(IBN)}^2 + V_{OS(IBP)}^2} \quad (97) \text{ Statistically adding the offset components. More realistic estimate.}$$

$$G_n = \frac{R_f}{R_g} + 1 \quad (98) \text{ Noise gain of op amp (always non-inverting gain)}$$

$$V_{OS(RTO)} = V_{OS(RTI)} \cdot G_n \quad (99) \text{ Offset referred to the output}$$

Where

\$R_f, R_g\$ = the feedback and gain setting resistors

\$R_{IN}\$ = resistance seen by noninverting input

\$I_{BN}, I_{BP}\$ = the current flowing from the inverting (\$I_{BN}\$) and noninverting (\$I_{BP}\$) op amp input as specified in the data sheet

\$V_{os(amp)}\$ = the input offset voltage specification from the op amp data sheet

\$V_{OS(RTI)}\$ = this is the offset referred to the input. This can be either \$V_{os(\text{total worst})}\$ or

\$V_{os(\text{total stat})}\$.

Op amp bandwidth

$$GBW = G_n \cdot BW \quad (100) \text{ Gain bandwidth product defined}$$

Where

GBW = gain bandwidth product, listed in op amp data sheet specification table

G_n = closed loop noise gain, always non-inverting gain

BW = the bandwidth limitation of the amplifier

Example

Determine bandwidth using equation 95, where

$G_n = 100$ (from amplifier configuration)

GBW = 22MHz (from data sheet)

Answer

$$BW = \frac{GBW}{G_n} = \frac{22\text{MHz}}{100} = 220\text{kHz}$$

Note that the same result can be graphically determined using the A_{OL} curve as shown below.

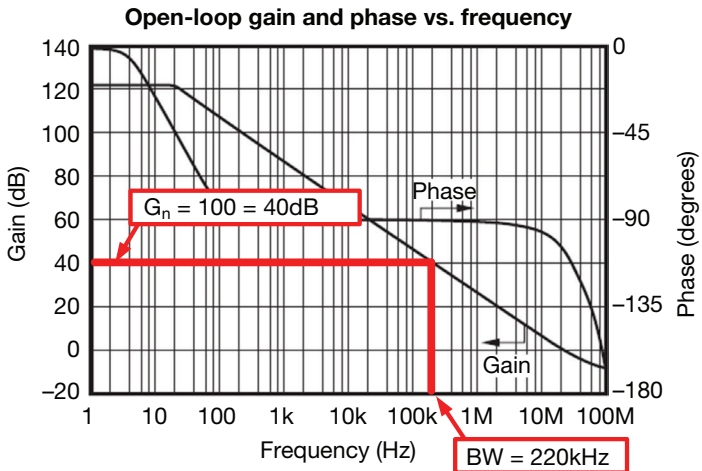

Figure 36: Using A_{OL} to find closed-loop bandwidth

Small signal step response

$$\tau_R = \frac{0.35}{f_C} \quad (101) \text{ Rise time for a small signal step}$$

Where

τ_R = the rise time of a small signal step response

f_C = the closed-loop bandwidth of the op amp circuit

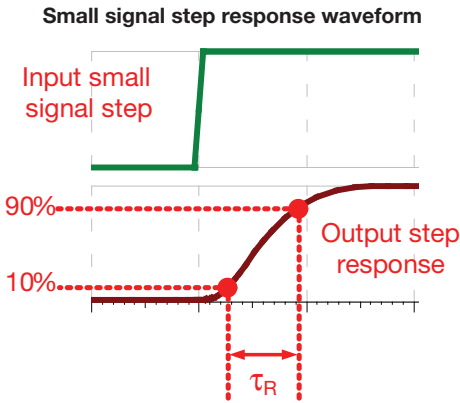

Figure 37: Small signal step response

Full power bandwidth

$$V_P = \frac{SR}{2\pi f} \quad (102) \text{ Maximum output without slew-rate induced distortion}$$

Where

V_P = maximum peak output voltage before slew induced distortion occurs

SR = slew rate

f = frequency of applied signal

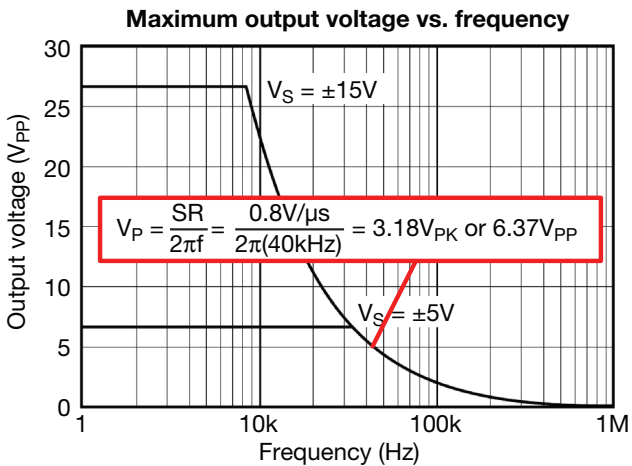

Figure 38: Maximum output without slew-rate induced distortion

Notice that the above figure is graphed using equation 96 for the OPA277. The example calculation shows the peak voltage for the OPA277 at 40kHz. This can be determined graphically or with the equation.

Example

$$V_P = \frac{SR}{2\pi f} = \frac{0.8V/\mu s}{2\pi(40kHz)} = 3.18V_{PK} \text{ or } 6.37V_{PP}$$

Large signal response (slew rate)

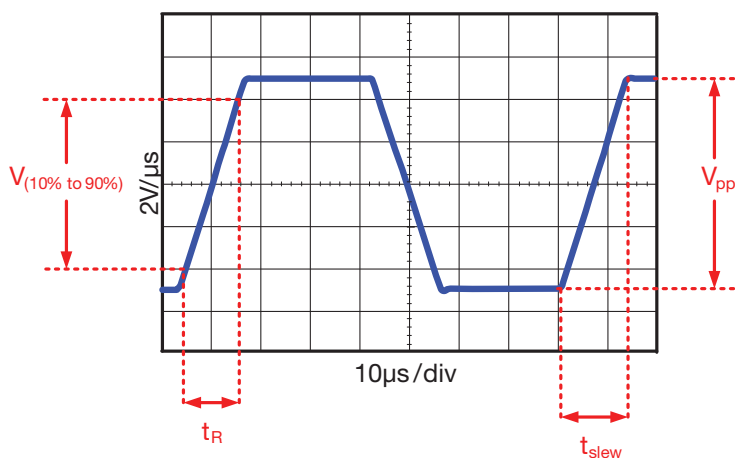

Figure 39: Large signal step response

$$t_R = \frac{V_{(10\% \text{ to } 90\%)}}{SR} \quad (103) \text{ Rise time for large signal step response}$$

$$t_{slew} \approx \frac{V_{pp}}{SR} \quad (104) \text{ Approximate total time for waveform to transition from peak to peak for large signal response}$$

Where

$V_{(10\% \text{ TO } 90\%)}$ = the change in output voltage from 10% to 90% for a step input

SR = the slew rate of the amplifier

V_{pp} = peak-to-peak square wave voltage for a step response

Settling Time

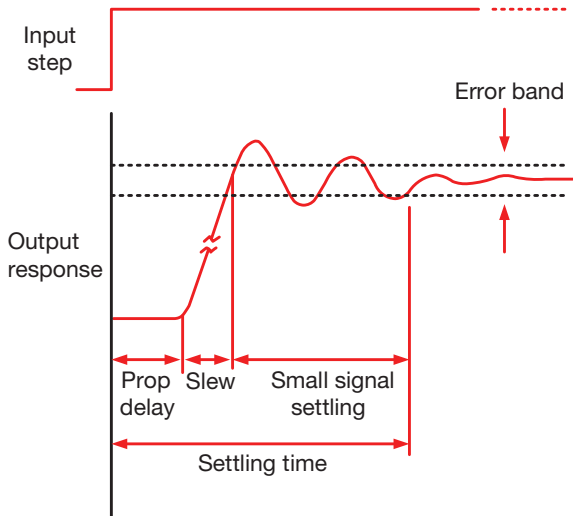

Figure 40: Small signal step response

Where

Settling time = the time from when an input step is applied until the output settles inside an error guard band. Settling time is measured with a large step (near full scale) input.

Prop delay = propagation delay. The time from when the input step is applied until the output begins to respond

Slew = the output is transitioning at the maximum rate given by the slew rate specification in the amplifier data sheet

Combining noise sources

$$e_{nT} = \sqrt{(e_{n1})^2 + (e_{n2})^2} \quad (105) \text{ Combining two uncorrelated noise sources}$$

$$e_{nT} = \sqrt{(e_{n1})^2 + (e_{n2})^2 + 2 \cdot C \cdot e_{n1} \cdot e_{n2}} \quad (106) \text{ Combining two correlated noise sources}$$

Where

e_{nT} = total noise

e_{n1} , e_{n2} = noise sources

C = correlation factor, ranges from -1 to +1. $C=0$ for uncorrelated sources, $C=-1$ for inversely correlated, and $C=+1$ for directly correlated.

Averaging noise sources

$$e_{nAvg} = \frac{e_n}{\sqrt{N}} \quad (107) \text{ Averaging noise}$$

Where

e_{nAvg} = the noise amplitude after averaging

e_n = the noise amplitude before averaging

N = the number of averages

Noise bandwidth calculation

$$BW_n = K_n \cdot f_c \quad (108) \text{ Noise bandwidth}$$

Where

BW_n = noise bandwidth of the system

K_n = the brick wall correction factor for different filter order

f_c = -3 dB bandwidth of the system

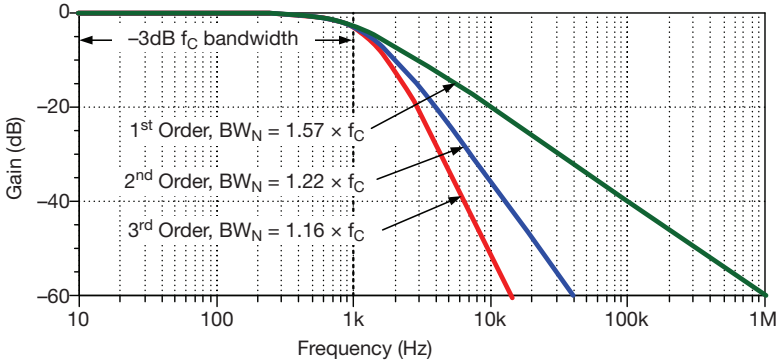

Figure 41: Op amp bandwidth for three different filter orders

Table 17: Brick wall correction factors for noise bandwidth

Number of poles	K_n brick wall correction factor
1	1.57
2	1.22
3	1.13
4	1.12

Broadband total noise calculation

$$E_{n(BB)} = e_n \cdot \sqrt{BW_n} \quad (109) \text{ Total RMS noise from broadband}$$

Where

$E_{n(BB)}$ = total RMS noise from broadband noise

e_n = broadband noise spectral density (nV/ $\sqrt{\text{Hz}}$)

BW_n = noise bandwidth (Hz)

1/f total noise calculation

$$E_{n(\text{normal})} = e_{n(\text{flicker})} \sqrt{f_o} \quad (110) \text{ Normalized 1/f noise at 1 Hz}$$

Where

$E_{n(\text{normal})}$ = 1/f noise normalized to 1 Hz

$e_{n(\text{flicker})}$ = noise spectral density measured in the 1/f region

f_o = the frequency at which the 1/f noise $e_{n(\text{flicker})}$ is measured

$$E_{n(\text{flicker})} = E_{n(\text{normal})} \sqrt{\ln\left(\frac{f_H}{f_L}\right)} \quad (111) \text{ 1/f total noise calculation}$$

Where

$E_{n(\text{flicker})}$ = total RMS noise from flicker

$E_{n(\text{normal})}$ = 1/f noise normalized to 1Hz

f_H = upper cutoff frequency or noise bandwidth

f_L = lower cutoff frequency, normally set to 0.1Hz

Table 18: Peak-to-peak conversion

Number of standard deviations	Percent chance reading is in range
2σ (same as ±1σ)	68.3%
3σ (same as ±1.5σ)	86.6%
4σ (same as ±2σ)	95.4%
5σ (same as ±2.5σ)	98.8%
6σ (same as ±3σ)	99.7%
6.6σ (same as ±3.3σ)	99.9%

Thermal noise calculation

$$E_{n(R)} = \sqrt{4 \cdot k \cdot T_K \cdot R \cdot BW_n} \quad (112) \text{ Total RMS thermal noise}$$

$$e_{n(R)} = \sqrt{4 \cdot k \cdot T_K \cdot R} \quad (113) \text{ Thermal noise spectral density}$$

Where

$E_{n(R)}$ = total RMS noise from resistance, also called thermal noise (V RMS)

$e_{n(R)}$ = noise spectral density from resistance, also called thermal noise ($V/\sqrt{\text{Hz}}$)

k = Boltzmann's constant $1.38 \times 10^{-23} \text{ J/K}$

T_K = temperature in Kelvin, to convert degrees Celsius to Kelvin $T_K = T_C + 273.15$

BW_n = noise bandwidth in Hz

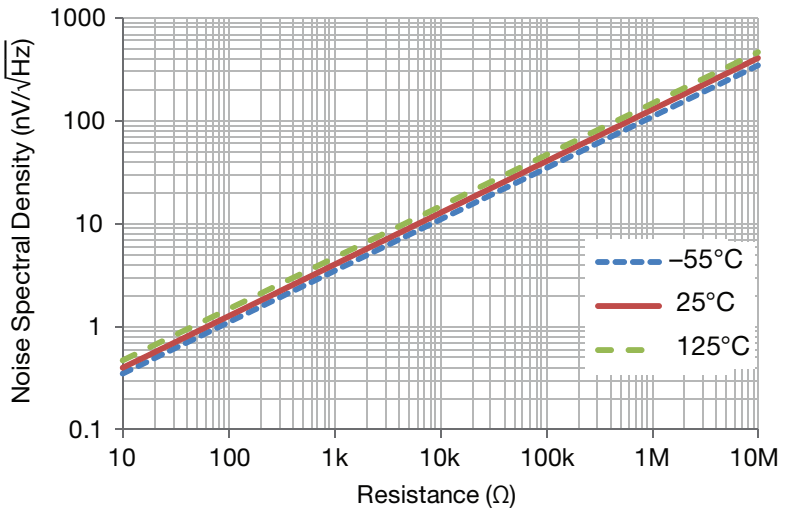

Figure 42: Noise spectral density vs. resistance

Op amp noise model

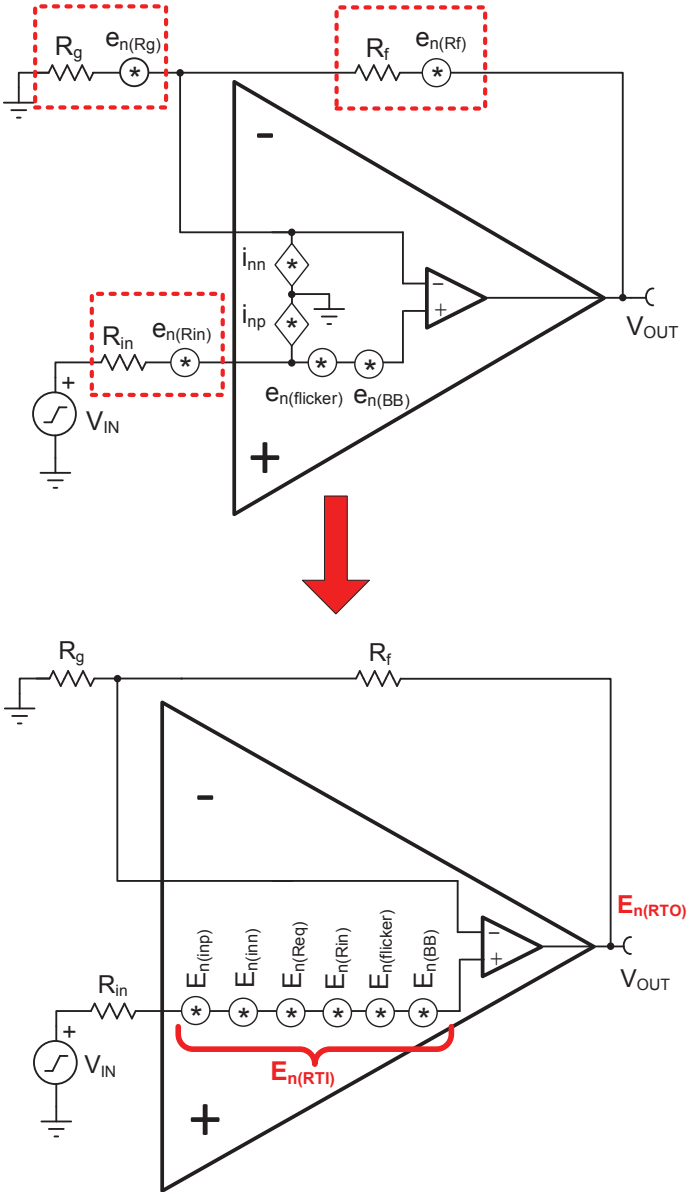

Figure 43: Op amp noise model

Total noise calculations

$$R_{eq} = \frac{R_f \cdot R_g}{R_f + R_g} \quad (114) \text{ Equivalent feedback resistance}$$

$$e_{n(\text{inn})} = i_{nn} \cdot R_{eq} \quad (115) \text{ Noise RTI from } i_{nn} \text{ flowing into feedback resistors}$$

$$e_{n(\text{inp})} = i_{np} \cdot R_{in} \quad (116) \text{ Noise RTI from } i_{np} \text{ flowing into input resistance}$$

$$e_{n(\text{Req})} = \sqrt{4 \cdot k \cdot T_K \cdot R_{eq}} \quad (117) \text{ Thermal noise RTI from feedback network}$$

$$e_{n(\text{Rin})} = \sqrt{4 \cdot k \cdot T_K \cdot R_{in}} \quad (118) \text{ Thermal noise RTI from input resistor}$$

$$e_{n(\text{BB})} \quad (119) \text{ Broadband noise from data sheet}$$

$$E_n = e_n \cdot \sqrt{BW_n} \quad (120) \text{ General equation to convert spectral density to RMS}$$

$$E_{n(\text{normal})} = e_{n(\text{flicker})} \sqrt{f_o} \quad (121) \text{ Flicker noise normalized to 1Hz}$$

$$E_{n(\text{flicker})} = E_{n(\text{normal})} \cdot \sqrt{\ln\left(\frac{f_H}{f_L}\right)} \quad (122) \text{ Op amp RMS flicker noise}$$

$$E_{n(\text{RTI})} = \sqrt{E_{n(\text{BB})}^2 + E_{n(\text{flicker})}^2 + E_{n(\text{Rin})}^2 + E_{n(\text{Req})}^2 + E_{n(\text{inp})}^2 + E_{n(\text{inn})}^2} \quad (123) \text{ Total noise RTI}$$

$$G_n = \frac{R_f}{R_g} + 1 \quad (124) \text{ Noise gain}$$

$$E_{n(\text{RTO})} = E_{n(\text{RTI})} \cdot G_n \quad (125) \text{ Total noise RTO}$$

Note 1: equations above were defined previously

Note 2: capital letter (e.g. “E”) indicates RMS noise, and lowercase letter (e.g. “e”) indicate noise density (e.g. $V / \sqrt{\text{Hz}}$)

RTO = referred to the output

RTI = referred to the input

AC response versus frequency (dominant 2-pole system)

Figure 43 illustrates a bode plot with four different examples of AC peaking.

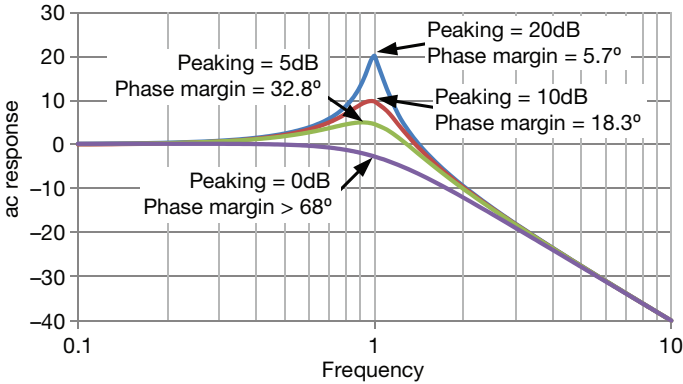

Figure 44: Stability – AC peaking relationship example

Phase margin versus AC peaking

This graph illustrates the phase margin for any given level of AC peaking. Note that 45° of phase margin or greater is required for stable operation.

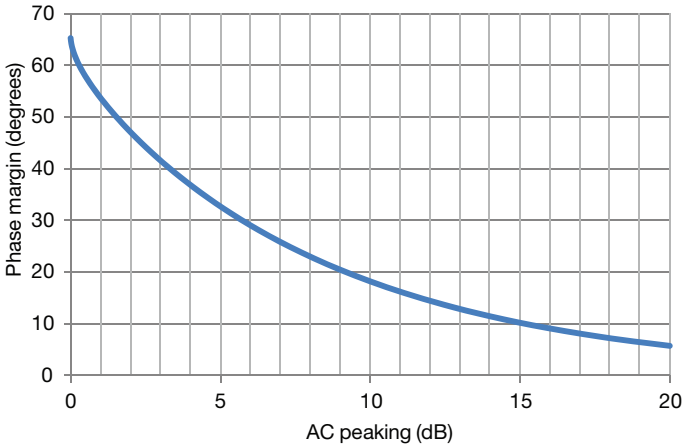

Figure 45: Stability – phase margin vs. peaking for a two-pole system

Transient overshoot (dominant 2-pole system)

Figure 46 illustrates a transient response with two different examples of percentage overshoot.

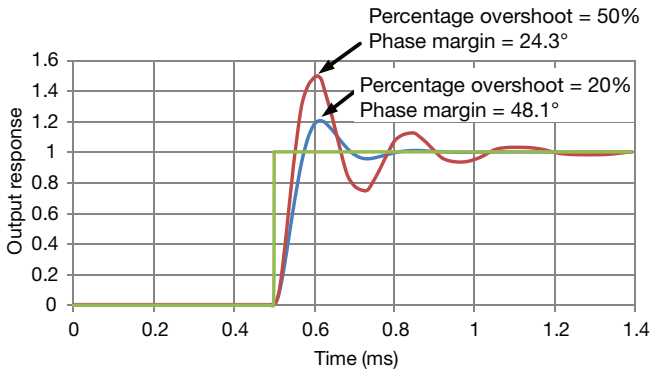

Figure 46: Stability – transient overshoot example

Phase margin versus percentage overshoot

This graph illustrates the phase margin for any given level of transient overshoot. Note that 45° of phase margin or greater is required for stable operation.

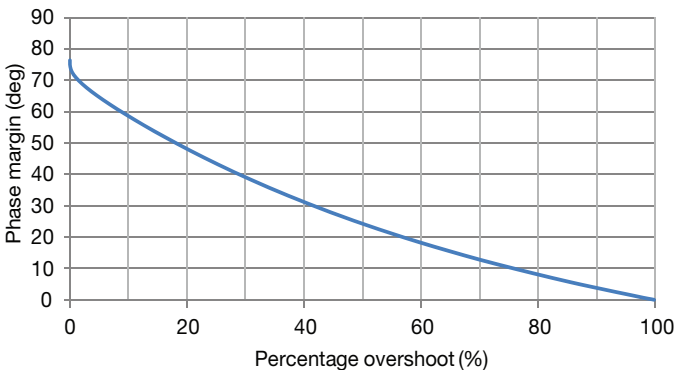

Figure 47: Stability – phase margin vs. percentage overshoot

Stability open loop SPICE analysis

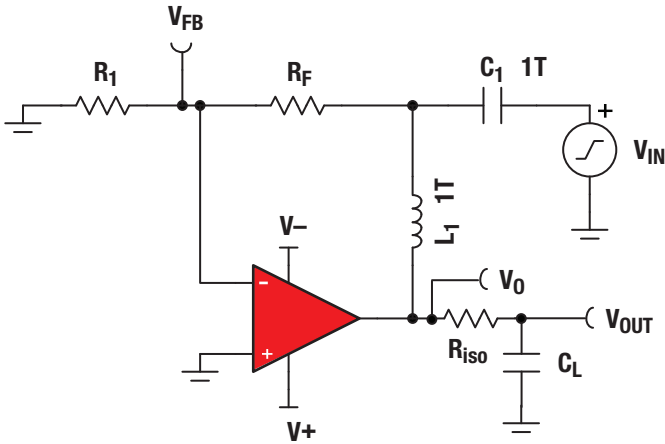

Figure 48: Common spice test circuit used for stability

$$A_{OL_LOADED} = \frac{V_O}{V_{FB}} \quad (126) \text{ Loaded open-loop gain}$$

$$\beta = V_{FB} \quad (127) \text{ Feedback factor}$$

$$\frac{1}{\beta} = \frac{1}{V_{FB}} \quad (128) \text{ Closed-loop noise gain}$$

$$A_{OL_LOADED} \times \beta = V_O \quad (129) \text{ Loop gain}$$

Where

V_O = the voltage at the output of the op amp

V_{OUT} = the voltage output delivered to the load, which may be important to the application but is not considered in stability analysis

V_{FB} = feedback voltage

R_F , R_1 , R_{iso} and C_L = the op amp feedback network and load.

Other op amp topologies will have different feedback networks; however, the test circuit will be the same for most cases.

Figure 47 shows the exception to the rule (multiple feedback).

C_1 and L_1 = components that facilitate SPICE analysis. They are large (1TF, 1TH) to make the circuit closed-loop for DC, but open loop for AC frequencies. SPICE requires closed-loop operation at DC for convergence.

Stability open loop SPICE analysis (cont.)

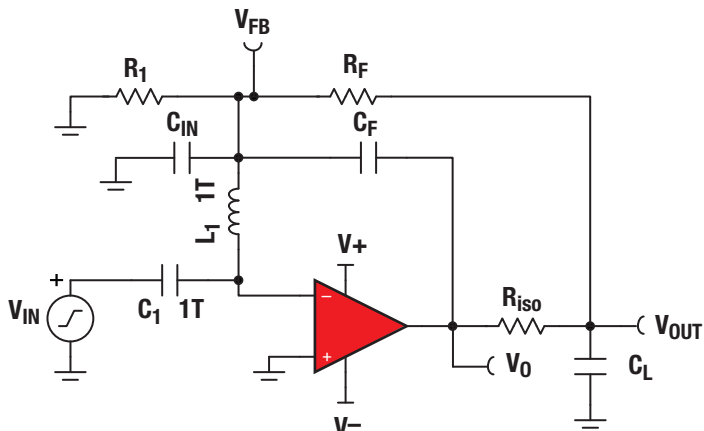

Figure 49: Alternative (multiple feedback) SPICE test circuit used for stability

$$A_{OL_LOADED} = V_O \quad (130) \text{ Loaded open loop gain}$$

$$\beta = \frac{V_{FB}}{V_O} \quad (131) \text{ Feedback factor}$$

$$\frac{1}{\beta} = \frac{V_O}{V_{FB}} \quad (132) \text{ Closed-loop noise gain}$$

$$A_{OL_LOADED} \times \beta = V_{FB} \quad (133) \text{ Loop gain}$$

Where

V_O = the voltage at the output of the op amp

V_{OUT} = the voltage output delivered to the load. This may be important to the application but is not considered in stability analysis.

V_{FB} = feedback voltage

R_F , R_1 , R_{iso} and C_F = the op amp feedback network. Because there are two paths for feedback, the loop is broken at the input.

C_1 and L_1 = components that facilitate SPICE analysis. They are large (1TF, 1TH) to make the circuit closed loop for DC, but open loop for AC frequencies. SPICE requires closed-loop operation at DC for convergence.

C_{IN} = the equivalent input capacitance taken from the op amp datasheet. This capacitance normally does not need to be added because the model includes it. However, when using this simulation method the capacitance is isolated by the 1TH inductor.

Stability transient square wave lab test

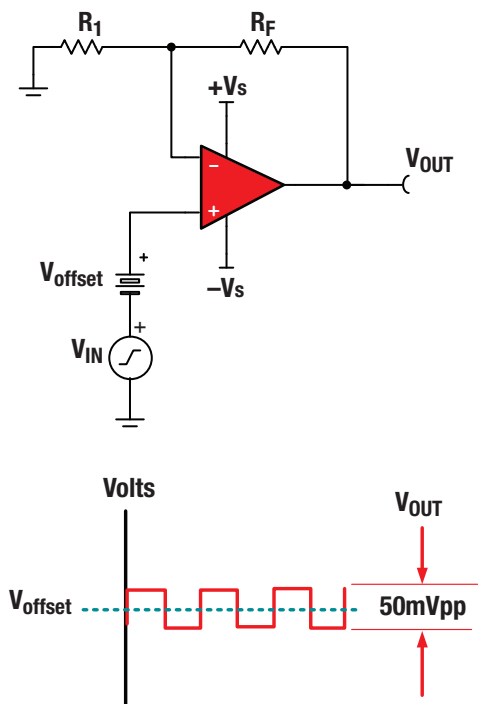

Figure 50: Transient real world stability test

Test tips

- Choose test frequency $\ll f_{cl}$
- Small signal ($V_{pp} \leq 50$ mV) ac output square wave (for example, 1 kHz)
- Adjust V_{IN} amplitude to yield output ≤ 50 mVpp
- Worst case is usually when $V_{offset} = 0$ (largest R_O , for $I_{OUT} = 0A$)
- Use V_{offset} as desired to check all output operating points for stability
- Set scope = AC coupled and expand vertical scope scale to look for amount of overshoot, undershoot, and ringing on V_{OUT}
- Use 1x attenuation scope probe on V_{OUT} for best resolution
- Use percentage overshoot to determine phase margin using Figure 47

Stability AC sine wave lab test

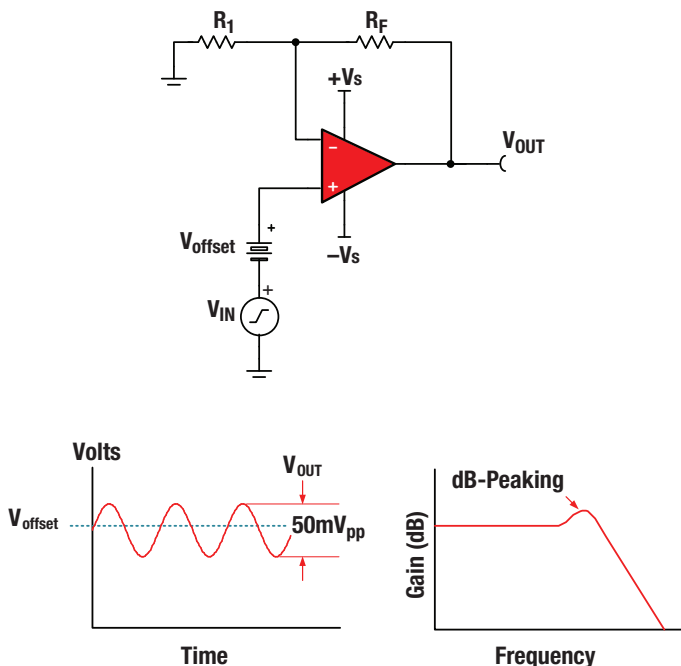

Figure 51: AC sweep real world stability test

Test tips

- Small signal ($V_{pp} \leq 50$ mV) AC output sine wave
- Adjust V_{IN} amplitude to yield output ≤ 50 mVpp
- Worst case is usually when $V_{offset} = 0$ (largest R_O , for $I_{OUT} = 0A$)
- Use V_{offset} as desired to check all output operating points for stability
- Sweep input frequency or use network analyzer to automatically sweep frequency
- Use AC coupling
- Use 1x attenuation scope probe on V_{OUT} for best resolution
- Use AC peaking in decibels to determine phase margin using Figure 45

Power dissipation calculation

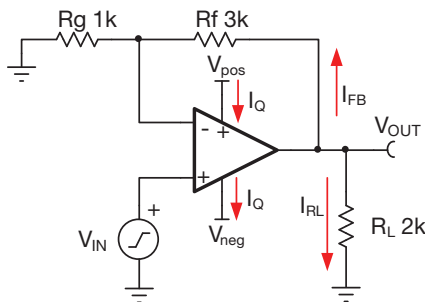

Figure 52: Current and power dissipation for non-inverting amplifier

Non-inverting amplifier power dissipation for specific V_{OUT}

$$I_{RL} = \frac{V_{OUT}}{R_L} \quad (134) \text{ Current through load resistor}$$

$$I_{FB} = \frac{V_{OUT}}{R_F + R_g} \quad (135) \text{ Current through feedback network}$$

$$P_L = (|I_{RL}| + |I_{FB}|)(|V_{sup}| - |V_{OUT}|) \quad (136) \text{ Power dissipated inside op amp from load current.}$$

$V_{sup} = V_{pos}$ if the amplifier is sourcing.
 $V_{sup} = V_{neg}$ if the amplifier is sinking.

$$P_Q = (V_{pos} - V_{neg}) \cdot I_Q \quad (137) \text{ Total power from quiescent current}$$

$$P_T = P_L + P_Q \quad (138) \text{ Total power dissipated inside the op amp}$$

Non-inverting amplifier maximum power dissipation

$$R_{L_EQ} = (R_L) \parallel (R_g + R_F) \quad (139) \text{ Equivalent load resistance}$$

$$P_{dc_max} = \frac{V_{sup}^2}{4 \cdot R_{L_EQ}} \quad (140) \text{ Maximum DC power dissipation inside the amplifier. Max power occurs when } V_{OUT} = \frac{1}{2} V_{sup}.$$

$V_{sup} = V_{pos} = |V_{neg}|$ for a dual symmetrical supply.
 $V_{sup} = V_{pos}$ for single supply configuration.

$$P_{ac_max_avg} = \frac{2 \cdot V_{sup}^2}{\pi^2 \cdot R_{L_EQ}} \quad (141) \text{ Maximum AC average power dissipation for a sinusoidal signal on dual supply configuration. Max average power occurs when the } V_{OUT_pk} = (2 \cdot V_{cc} / \pi).$$

$V_{sup} = V_{pos} = V_{neg}$ for a dual symmetrical supply. For single supply max average AC power is equal to P_{dc_max} . This assumes sinewave is centered at mid-supply.

$$T_j = \theta_{ja} \cdot P + T_a \quad (142) \text{ Junction temperature as a function of power and ambient temperature. } T_j = \text{junction temperature. } \theta_{ja} = \text{junction to ambient thermal resistance. } P = P_{dc_max} \text{ or } P_{ac_max_avg} \text{ depending on your application. } T_a = \text{ambient temperature.}$$

Power dissipation calculation (cont.)

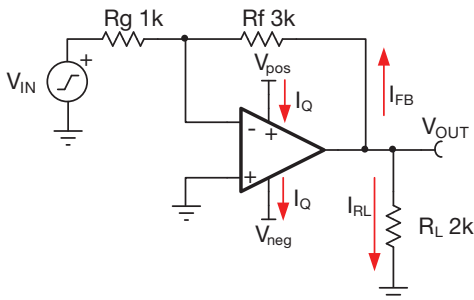

Figure 53: Current and power dissipation for inverting amplifier

Inverting amplifier power dissipation for specific V_{OUT}

$$I_{RL} = \frac{V_{OUT}}{R_L} \quad (143) \text{ Current through load resistor}$$

$$I_{FB} = \frac{V_{OUT}}{R_F} \quad (144) \text{ Current through feedback network}$$

$$P_L = (|I_{RL}| + |I_{FB}|)(|V_{sup}| - |V_{OUT}|) \quad (145) \text{ Power dissipated in op amp from load current, where } V_{sup} = V_{pos} \text{ if the amplifier is sourcing, or } V_{neg} \text{ if the amplifier is sinking}$$

$$P_Q = (V_{pos} - V_{neg}) \cdot I_Q \quad (146) \text{ Total power from quiescent current}$$

$$P_T = P_L + P_Q \quad (147) \text{ Total power dissipated inside the op amp}$$

$$R_{L_EQ} = (R_L) \parallel (R_F) \quad (148) \text{ Equivalent load resistance}$$

Inverting amplifier maximum power dissipation

$$P_{dc_max} = \frac{V_{sup}^2}{4 \cdot R_{L_EQ}} \quad (149) \text{ Maximum DC power dissipation inside the amplifier. Max power occurs when } V_{OUT} = \frac{1}{2} V_{sup}. V_{sup} = V_{pos} = |V_{neg}| \text{ for a dual symmetrical supply. } V_{sup} = V_{pos} \text{ for single supply configuration.}$$

$$P_{ac_max_avg} = \frac{2 \cdot V_{sup}^2}{\pi^2 \cdot R_{L_EQ}} \quad (150) \text{ Maximum AC average power dissipation for a sinusoidal signal on dual supply configuration. Max average power occurs when the } V_{OUT_pk} = (2 \cdot V_{cc} / \pi). V_{sup} = V_{pos} = V_{neg} \text{ for a dual symmetrical supply. For single supply max average AC power is equal to } P_{dc_max}. \text{ This assumes sinewave is centered at mid-supply.}$$

$$T_j = \theta_{ja} \cdot P + T_a \quad (151) \text{ Junction temperature as a function of power and ambient temperature. } T_j = \text{ junction temperature. } \theta_{ja} = \text{ junction to ambient thermal resistance. } P = P_{dc_max} \text{ or } P_{ac_max_avg} \text{ depending on your application. } T_a = \text{ ambient temperature.}$$

Electrical overstress (EOS) protection

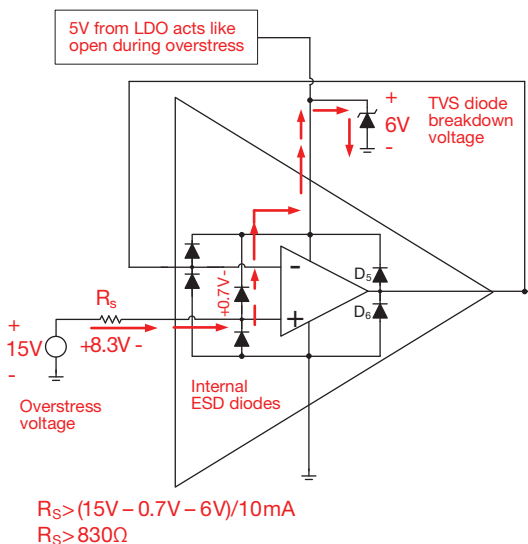

Figure 54: EOS protection during overstress event

Method for selecting EOS protection

1. Choose a unidirectional transient voltage suppressor (TVS) diode that has a reverse standoff equal to the normal operating supply voltage. For example, reverse standoff of $V_R = 5V$, for an amplifier with a 5V supply. This assures a low TVS diode leakage.
2. Try to find a TVS diode that also breaks down below the absolute maximum rating for the device that is being protected. For example, breakdown of $V_{BR} \leq 6V$ for an absolute maximum of 6V. Note that this may not always be possible. Choose the lowest breakdown available.
3. Choose a series resistor, R_s , to limit the current to the absolute maximum input current. This is commonly 10mA for many devices.
 $R_s > (V_{overstress} - 0.7V - V_{BR})$. For this example,
 $R_s = (15V - 0.7V - 6V) = 830\Omega$.
4. Increase the value of the series resistor for more design margin.

Electrical overstress (EOS) protection

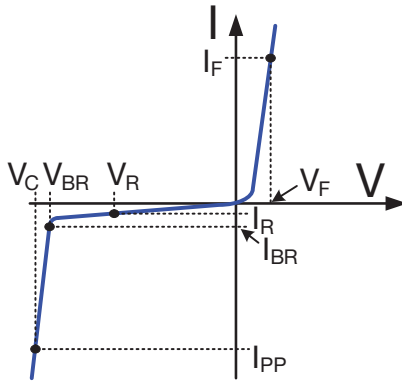

Figure 55: Typical unidirectional TVS I-V curve

Where

V_{BR} = breakdown voltage

V_R = stand-off voltage. The normal operating voltage with a guaranteed reverse leakage current.

V_C = clamping voltage. The voltage across the TVS when maximum current is flowing.

V_F = forward voltage drop, typically 0.7V for a unipolar TVS diode

I_{BR} = breakdown current @ V_{BR}

I_R = reverse leakage @ V_R . Typically in the microamps.

I_F = forward current @ V_F

I_{PP} = maximum peak pulse current @ V_C , applied for a limited time (microseconds)

Notes

PCB and Wire

- PCB trace resistance for 1oz and 2oz Cu
- Conductor spacing in a PCB for safe operation
- Current carrying capacity of copper conductors
- Package types and dimensions
- PCB trace capacitance and inductance
- PCB via capacitance and inductance
- Common coaxial cable specifications
- Coaxial cable equations
- Resistance per length for wire types
- Maximum current for wire types

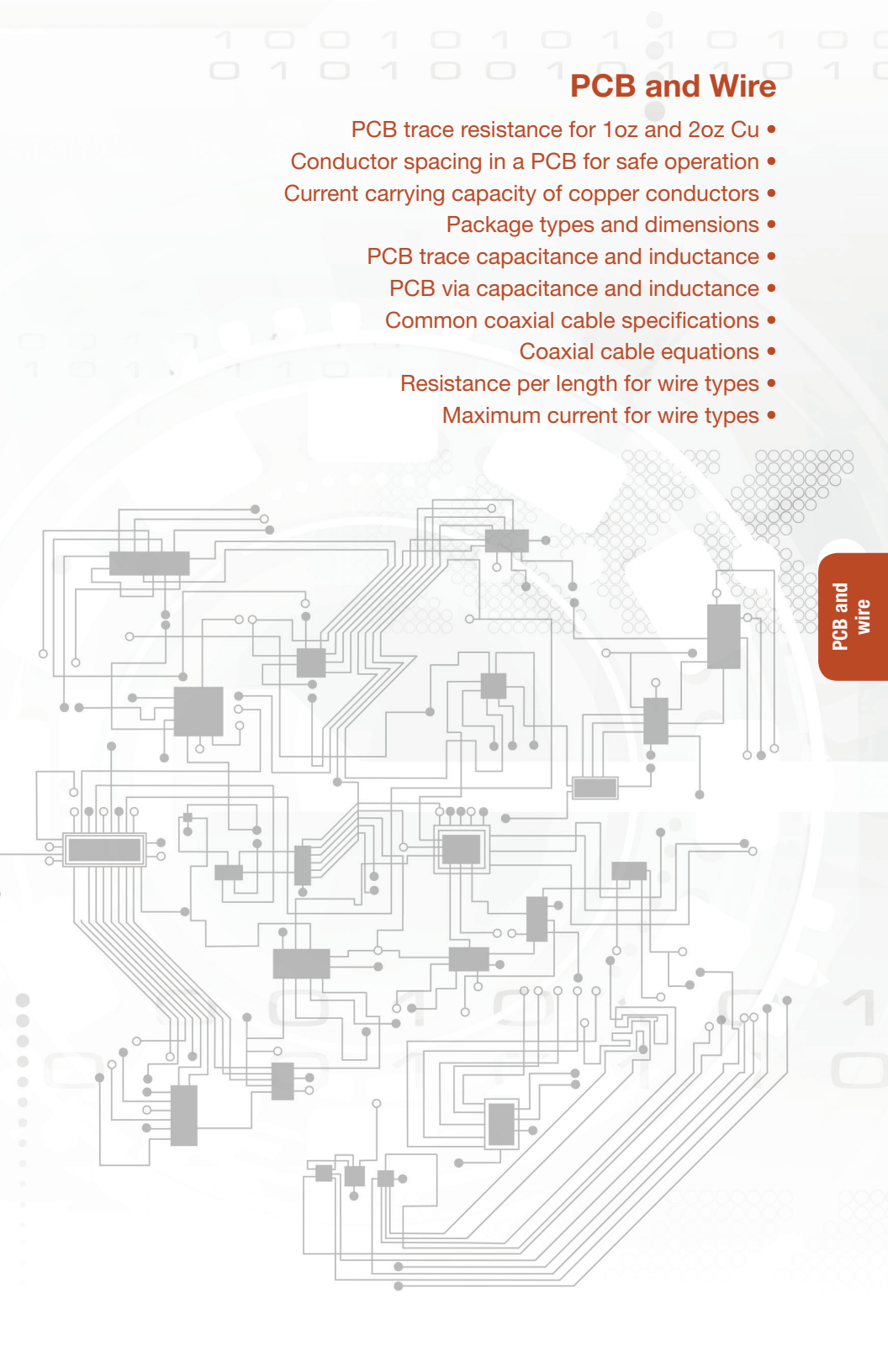

Table 19: Printed circuit board conductor spacing

Voltage between conductors (DC or AC peaks)	Minimum spacing						
	Bare board				Assembly		
	B1	B2	B3	B4	A5	A6	A7
0-15	0.05 mm [0.00197 in]	0.1 mm [0.0039 in]	0.1 mm [0.0039 in]	0.05 mm [0.00197 in]	0.13 mm [0.00512 in]	0.13 mm [0.00512 in]	0.13 mm [0.00512 in]
16-30	0.05 mm [0.00197 in]	0.1 mm [0.0039 in]	0.1 mm [0.0039 in]	0.05 mm [0.00197 in]	0.13 mm [0.00512 in]	0.25 mm [0.00984 in]	0.13 mm [0.00512 in]
31-50	0.1 mm [0.0039 in]	0.6 mm [0.024 in]	0.6 mm [0.024 in]	0.13 mm [0.00512 in]	0.13 mm [0.00512 in]	0.4 mm [0.016 in]	0.13 mm [0.00512 in]
51-100	0.1 mm [0.0039 in]	0.6 mm [0.024 in]	1.5 mm [0.0591 in]	0.13 mm [0.00512 in]	0.13 mm [0.00512 in]	0.5 mm [0.020 in]	0.13 mm [0.00512 in]
101-150	0.2 mm [0.0079 in]	0.6 mm [0.024 in]	3.2 mm [0.126 in]	0.4 mm [0.016 in]	0.4 mm [0.016 in]	0.8 mm [0.031 in]	0.4 mm [0.016 in]
151-170	0.2 mm [0.0079 in]	1.25 mm [0.0492 in]	3.2 mm [0.126 in]	0.4 mm [0.016 in]	0.4 mm [0.016 in]	0.8 mm [0.031 in]	0.4 mm [0.016 in]
171-250	0.2 mm [0.0079 in]	1.25 mm [0.0492 in]	6.4 mm [0.252 in]	0.4 mm [0.016 in]	0.4 mm [0.016 in]	0.8 mm [0.031 in]	0.4 mm [0.016 in]
251-300	0.2 mm [0.0079 in]	1.25 mm [0.0492 in]	12.5 mm [0.492 in]	0.4 mm [0.016 in]	0.4 mm [0.016 in]	0.8 mm [0.031 in]	0.8 mm [0.031 in]
301-500	0.25 mm [0.00984 in]	2.5 mm [0.0984 in]	12.5 mm [0.492 in]	0.8 mm [0.031 in]	0.8 mm [0.031 in]	1.5 mm [0.0591 in]	0.8 mm [0.031 in]

Where

B1 = internal conductors

B2 = external conductors uncoated sea level to 3050m

B3 = external conductors uncoated above 3050m

B4 = external conductors coated with permanent polymer coating (any elevation)

A5 = external conductors with conformal coating over assembly (any elevation)

A6 = external component lead/termination, uncoated, sea level to 3050m

A7 = external component lead termination, with conformal coating (any elevation)

Extracted with permission from IPC-2221B, Table 6-1

For additional information, the entire specification can be downloaded at

www.ipc.org

PCB and Wire

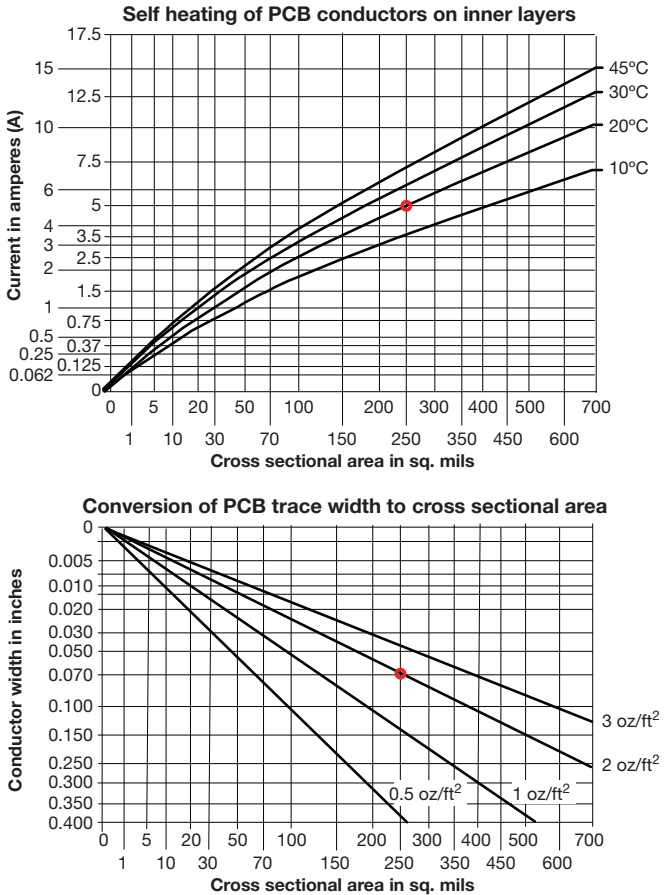

Figure 56: Self heating of PCB traces on inside layer

Example

Find the current that will cause a 20°C temperature rise in a PCB trace that is 0.1 inch wide and uses 2 oz/ft² copper. (Assume traces are on inner layer of PCB.)

Answer

First translate 0.1 inch to 250 sq. mils. using bottom chart. Next find the current associated with 20°C and 250 sq. mils. using top chart (Answer = 5A).

Extracted with permission from IPC-2152, Figure 5-1
 For additional information the entire specification can be downloaded at www.ipc.org

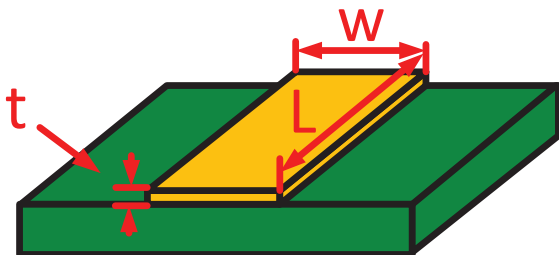

Figure 57: PCB trace resistance

$$R = \rho \frac{L}{t \cdot W} [1 + \alpha(T - 25^\circ\text{C})] \quad (152) \text{ Trace resistance}$$

Where

ρ = resistivity of trace (for copper = $17 \cdot 10^{-6} \Omega \cdot \text{mm}$)

α = temperature coefficient (for copper = $3.9 \cdot 10^{-3} / ^\circ\text{C}$)

L, W = length and width of trace in mm or mil. Note: L and W must both be in the same units.

t = thickness of trace in mm (1 oz copper = 0.0348mm, 2 oz copper = 0.0696mm)

T = temperature in $^\circ\text{C}$

Example

What is the resistance of a 20 mil long, 5 mil wide trace for a 1 oz Cu thickness at 25°C and 125°C ?

Answer

$R_{25^\circ\text{C}} = 1.95\text{m}\Omega$, $R_{125^\circ\text{C}} = 2.72\text{m}\Omega$

$$R = (17 \cdot 10^{-6} \Omega \cdot \text{mm}) \frac{20\text{mil}}{(0.0348\text{mm}) \cdot 5\text{mil}} [1 + 3.9 \cdot 10^{-3} / ^\circ\text{C} (125^\circ\text{C} - 25^\circ\text{C})] = 2.72\text{m}\Omega$$

PCB trace resistance for 1 oz-Cu

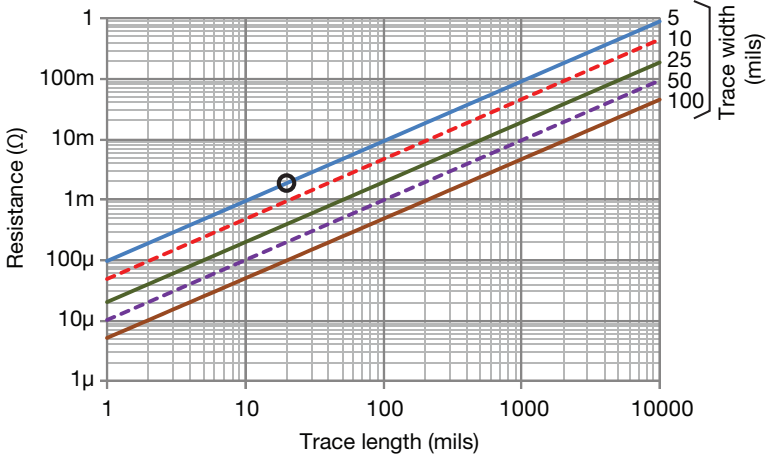

Figure 58: PCB trace resistance vs. length and width for 1 oz-Cu, 25°C

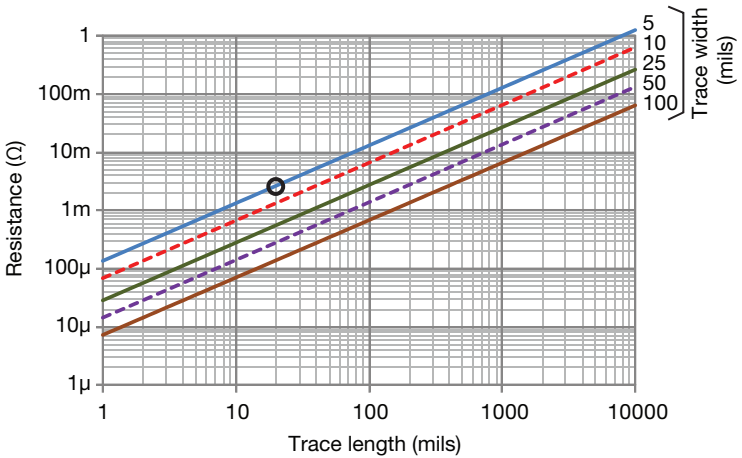

Figure 59: PCB trace resistance vs. length and width for 1 oz-Cu, 125°C

Example

What is the resistance of a 20 mil long, 5 mil wide trace for a 1 oz-Cu thickness at 25°C and 125°C?

Answer

R_{25C} = 2 mΩ, R_{125C} = 3 mΩ. The points are circled on the curves.

PCB trace resistance for 2 oz-Cu

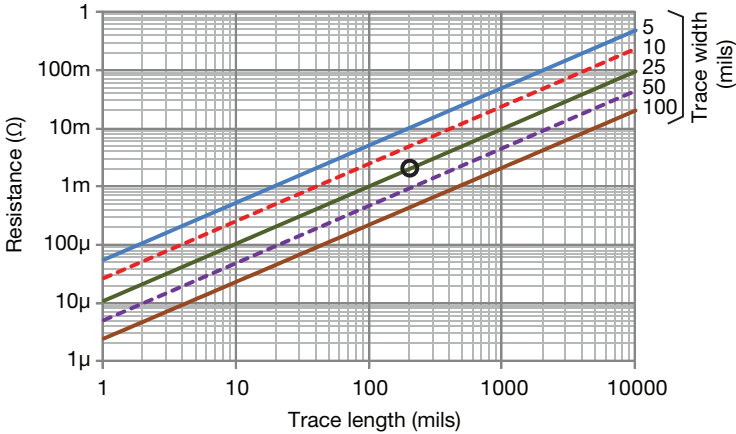

Figure 60: PCB trace resistance vs. length and width for 2 oz-Cu, 25°C

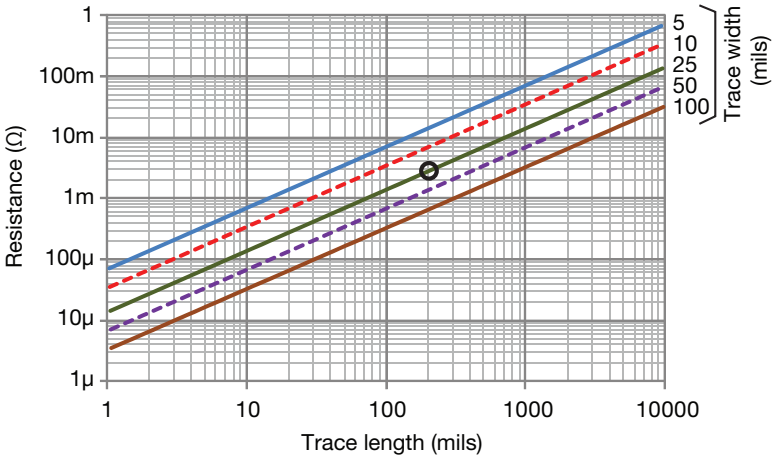

Figure 61: PCB trace resistance vs. length and width for 2 oz-Cu, 125°C

Example

What is the resistance of a 200 mil long, 25 mil wide trace for a 2 oz-Cu thickness at 25°C and 125°C?

Answer

$R_{25C} = 2 \text{ m}\Omega$, $R_{125C} = 3 \text{ m}\Omega$. The points are circled on the curves.

Common package type and dimensions

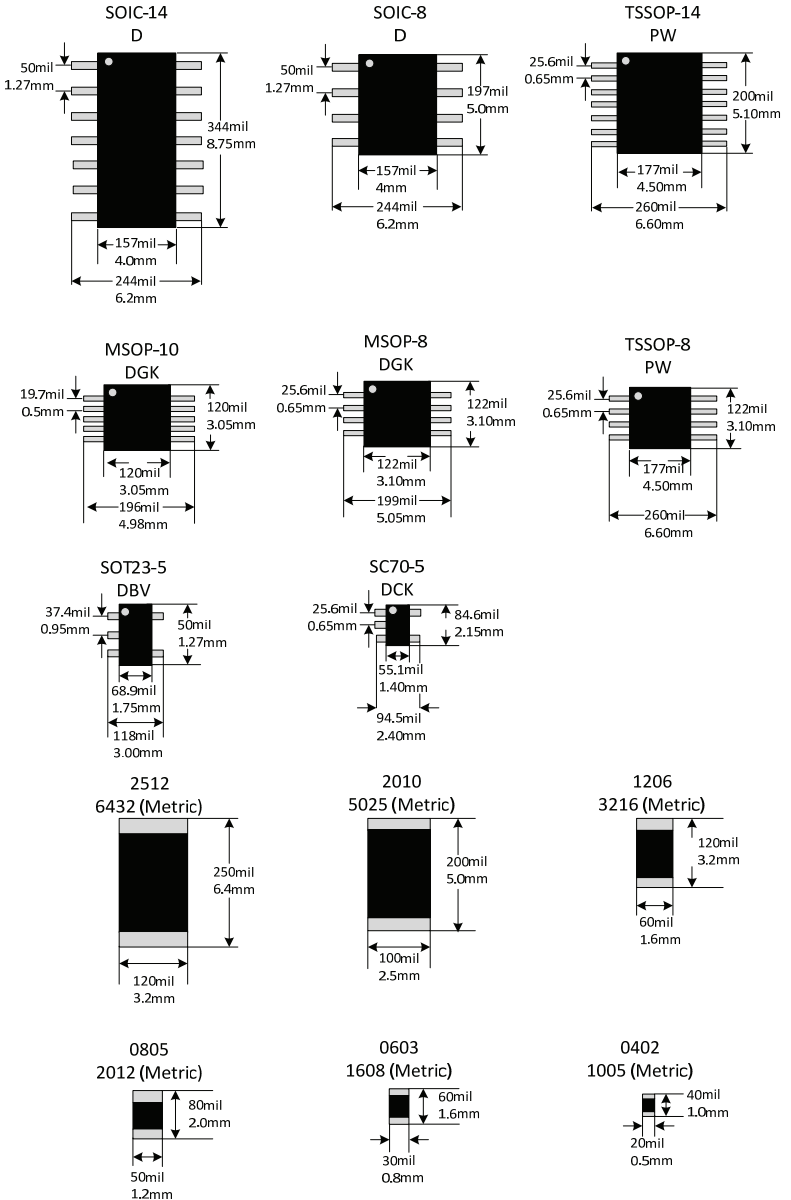

PCB parallel plate capacitance

$$C(\text{pF}) = \frac{k \cdot l \cdot w \cdot \epsilon_r}{h} \quad (153) \text{ Capacitance for parallel copper planes}$$

Where

k = permittivity of free space.

Both the metric and imperial version of the constant are given.

$k = 8.854 \times 10^{-3}$ pF/mm, or 2.247×10^{-4} pF/mil

l = length (metric in mm, or imperial in mil)

w = width (metric in mm, or imperial in mil)

h = separation between planes (metric in mm, or imperial in mil)

ϵ_r = PCB relative dielectric constant ($\epsilon_r \approx 4.5$ for FR-4)

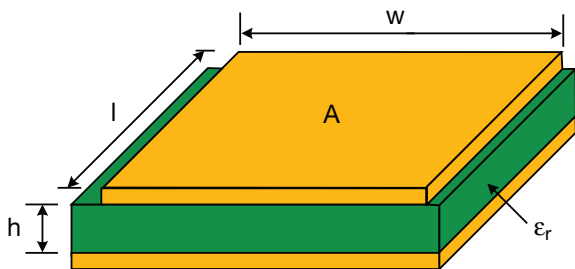

Figure 62: PCB parallel plate capacitance

Example

Calculate the total capacitance if $l = 5.08\text{mm}$, $w = 12.7\text{mm}$, $h = 1.575\text{mm}$, and $\epsilon_r = 4.5$.

Answer

$$C(\text{pF}) = \frac{(8.854 \times 10^{-3} \text{ pF/mm}) \times 5.08\text{mm} \times 12.7\text{mm} \times 4.5}{1.575\text{mm}} = 1.63\text{pF}$$

Example

Calculate the total capacitance if $l = 200\text{mil}$, $w = 500\text{mil}$, $h = 62\text{mil}$, and $\epsilon_r = 4.5$.

Answer

$$C(\text{pF}) = \frac{(2.247 \times 10^{-4} \text{ pF/mil}) \times 200\text{mil} \times 500\text{mil} \times 4.5}{62\text{mil}} = 1.63\text{pF}$$

PCB microstrip capacitance and inductance

$$L(\text{nH}) = k_L \cdot l \cdot \ln\left(\frac{5.98 \cdot h}{0.8 \cdot w + t}\right) \quad (154) \text{ Inductance for microstrip}$$

$$C(\text{pF}) = \frac{k_C \cdot l \cdot (\epsilon_r + 1.41)}{\ln\left(\frac{5.98 \cdot h}{0.8 \cdot w + t}\right)} \quad (155) \text{ Capacitance for microstrip}$$

$$Z_0 = \sqrt{\frac{L}{C}} = \frac{87\Omega}{\sqrt{(\epsilon_r + 1.41)}} \cdot \ln\left(\frac{5.98 \cdot h}{0.8 \cdot w + t}\right) \quad (156) \text{ Characteristic impedance for microstrip}$$

Where

k_L = PCB inductance per unit length.

Both the metric and imperial version of the constant are given.

$k_L = 2\text{nH/cm}$, or 5.071nH/in

k_C = PCB capacitance per unit length.

Both the metric and imperial version of the constant are given.

$k_C = 0.264\text{pF/cm}$, or 0.67056pF/in

l = length of microstrip (metric in cm, or imperial in inches)

w = width of microstrip (metric in mm, or imperial in mil)

t = thickness of copper (metric in mm, or imperial in mil)

h = separation between planes (metric in mm, or imperial in mil)

ϵ_r = PCB dielectric constant ($\epsilon_r \approx 4.5$ for FR-4)

For imperial:

Copper thickness (mils) = $1.37 \times (\text{number of ounces})$

i.e. 1oz Cu = 1.37mils

i.e. ½oz Cu = 0.684mils

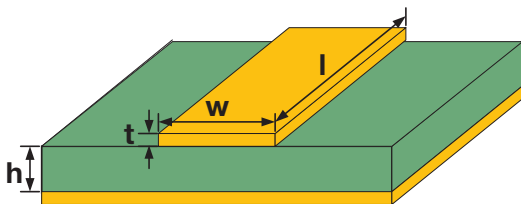

Figure 63: PCB Microstrip capacitance and inductance

Example

Calculate the total inductance and capacitance if $l = 2.54\text{cm}$, $w = 0.254\text{mm}$, $t = 0.0356\text{mm}$, $h = 0.8\text{mm}$, and $\epsilon_r = 4.5$ for FR-4.

Answer

$$L(\text{nH}) = (2\text{nH/cm}) \cdot (2.54\text{cm}) \cdot \ln\left(\frac{5.98 \cdot 0.8\text{mm}}{0.8 \cdot 0.254\text{mm} + 0.0356\text{mm}}\right) = 15.2\text{nH}$$

$$C(\text{pF}) = \frac{(0.264\text{pF/cm}) \cdot (2.54\text{cm}) \cdot (4.5 + 1.41)}{\ln\left(\frac{5.98 \cdot 0.8\text{mm}}{0.8 \cdot 0.254\text{mm} + 0.0356\text{mm}}\right)} = 1.3\text{pF}$$

PCB adjacent copper traces

$$C(\text{pF}) \approx \frac{k \cdot t \cdot l}{d} \quad (157) \text{ Same layer}$$

$$C(\text{pF}) \approx \frac{k \cdot \epsilon_r \cdot w \cdot l}{h} \quad (158) \text{ Different layers}$$

Where

l = length of the copper trace (mil or mm)

k = 8.854×10^{-3} pF/mm, or $k=2.247 \times 10^{-4}$ pF/mil

t = thickness of trace (mil or mm)

d = distance between traces if on same layer (mil or mm)

w = width of trace (mil or mm)

h = separation between planes (mil or mm)

ϵ_r = PCB dielectric constant ($\epsilon_r \approx 4.5$ for FR-4)

For imperial:

Copper thickness (mils) =
 $1.37 \times (\text{number of ounces})$

i.e. 1oz Cu = 1.37mils

i.e. ½oz Cu = 0.684mils

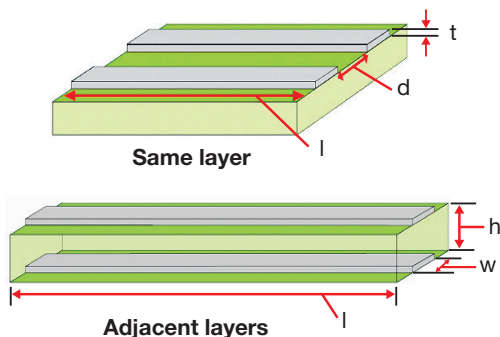

Figure 64: Capacitance for adjacent copper traces

Example

Calculate the total capacitance for both cases if $l = 2.54\text{mm}$, $t = 0.0348\text{mm}$, $d = 0.254\text{mm}$, $w = 0.635\text{mm}$, $h = 1.6\text{mm}$, and $\epsilon_r = 4.5$ for FR-4.

Answer

$$C(\text{pF}) \approx \frac{(8.854 \times 10^{-3} \text{pF/mm})(0.0348\text{mm})(2.54\text{mm})}{0.254\text{mm}} = 0.0031\text{pF} \quad (\text{same layer})$$

$$C(\text{pF}) \approx \frac{(8.854 \times 10^{-3} \text{pF/mm})(4.5\text{mm})(0.635\text{mm})(2.54\text{mm})}{1.6\text{mm}} = 0.04\text{pF} \quad (\text{adjacent layers})$$

Example

Calculate the total capacitance for both cases if $l = 100\text{mil}$, $t = 1.37\text{mil}$, $d = 10\text{mil}$, $w = 25\text{mil}$, $h = 63\text{mil}$, and $\epsilon_r = 4.5$ for FR-4.

Answer

$C = 0.0031\text{pF}$ (same layer), $C = 0.4\text{pF}$ (adjacent layers). Note: this is the same example as above with imperial units.

PCB via capacitance and inductance

$$L(\text{nH}) \approx k_L \cdot h \left[1 + \ln \left(\frac{4h}{d} \right) \right] \quad (159) \text{ Inductance for via}$$

$$C(\text{pF}) \approx \frac{k_C \cdot \epsilon_r \cdot h \cdot d_1}{d_2 - d_1} \quad (160) \text{ Capacitance for via}$$

Where

k_L = PCB inductance per unit length.

Both the metric and imperial version of the constant are given.

$k_L = 0.2\text{nH/mm}$, or $5.076 \times 10^{-3}\text{nH/mil}$

k_C = PCB capacitance per unit length.

Both the metric and imperial version of the constant are given.

$k_C = 0.0555\text{pF/mm}$, or $1.41 \times 10^{-3}\text{pF/mil}$

h = separation between planes

d = diameter of via hole

d_1 = diameter of the pad surrounding the via

d_2 = distance to inner layer ground plane

ϵ_r = PCB dielectric constant ($\epsilon_r \approx 4.5$ for FR-4)

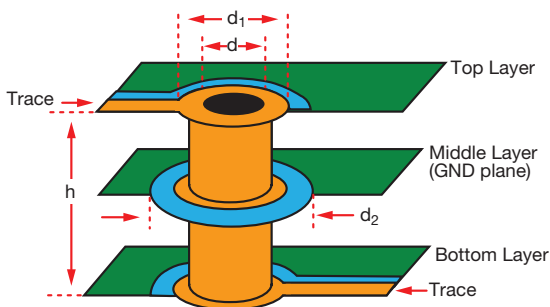

Figure 65: Inductance and capacitance of via

Example

Calculate the total inductance and capacitance if $h = 1.6\text{mm}$, $d = 0.4\text{mm}$, $d_1 = 0.8\text{mm}$, and $d_2 = 1.5\text{mm}$.

Answer

$$L(\text{nH}) \approx (0.2\text{nH/mm}) \cdot (1.6\text{mm}) \left[1 + \ln \left(\frac{4 \cdot 1.6\text{mm}}{0.4\text{mm}} \right) \right] = 1.2\text{nH}$$

$$C(\text{pF}) \approx \frac{(0.0555\text{pF/mm}) \cdot (4.5) \cdot (1.6\text{mm}) \cdot (0.8\text{mm})}{1.5\text{mm} - 0.8\text{mm}} = 0.46\text{pF}$$

Example

Calculate the total inductance and capacitance if $h = 63\text{mil}$, $d = 15.8\text{mil}$, $d_1 = 31.5\text{mil}$, and $d_2 = 59\text{mil}$.

Answer

$L = 1.2\text{nH}$, $C = 0.46\text{pF}$. Note: this is the same example as above with imperial units.

Table 20: Coaxial cable information

Type	Z_0	Capacitance / length (pF/feet)	Outside diameter (inches)	dB attenuation /100 ft at 750 MHz	Dielectric type	Application
RG-58	53.5 Ω	28.8	0.195	13.1	PE	Test equipment and RF power to a few hundred watts, and a couple hundred MHz
RG-8	52 Ω	29.6	0.405	5.96	PE	RF power to a few kW, up to several hundred MHz
RG-214/U	50 Ω	30.8	0.425	6.7	PE	
9914	50 Ω	26.0	0.405	4.0	PE	
RG-6	75 Ω	20	0.270	5.6	PF	Video and CATV applications. RF to a few hundred watts, up to a few hundred MHz, sometimes to higher frequencies if losses can be tolerated.
RG-59/U	73 Ω	29	0.242	9.7	PE	
RG-11/U	75 Ω	17	0.412	3.65	PE	RF power to a few kW, up to several hundred MHz
RG-62/U	93 Ω	13.5	0.242	7.1	ASP	Used in some test equipment and 100 Ω video applications
RG-174	50 Ω	31	0.100	23.5	PE	Miniature coax used primarily for test equipment interconnection. Usually short runs due to higher loss.
RG-178/U	50 Ω	29	0.071	42.7	ST	

Coaxial cable equations

$$\frac{C}{l} = \frac{2\pi\epsilon}{\ln\left(\frac{D}{d}\right)} \quad (161) \text{ Capacitance per length}$$

$$\frac{L}{l} = \frac{\mu}{2\pi} \ln\left(\frac{D}{d}\right) \quad (162) \text{ Inductance per length}$$

$$Z_o = \sqrt{\frac{L}{C}} = \frac{1}{2\pi} \cdot \sqrt{\frac{\mu}{\epsilon}} \cdot \ln\left(\frac{D}{d}\right) \quad (163) \text{ Characteristic impedance}$$

Where

L = inductance in henries (H)

C = capacitance in farads (F)

Z = impedance in ohms (Ω)

d = diameter of inner conductor

D = inside diameter of shield, or diameter of dielectric insulator

ϵ = dielectric constant of insulator ($\epsilon = \epsilon_r \epsilon_o$)

μ = magnetic permeability ($\mu = \mu_r \mu_o$)

l = length of the cable

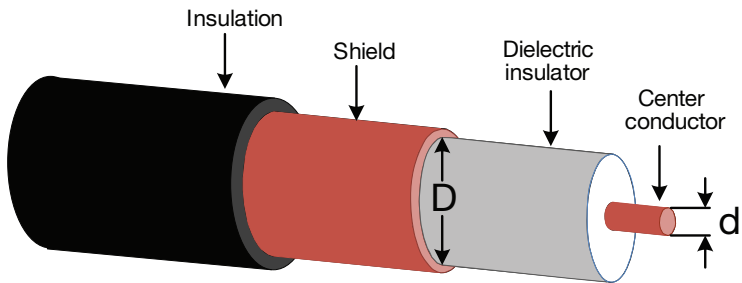

Figure 66: Coaxial cable cutaway

Table 21: Resistance per length for different wire types (AWG)

AWG	Stds	Outside diameter		Area		DC resistance	
		in	mm	circular mils	mm ²	Ω / 1000 ft	Ω / km
36	Solid	0.005	0.127	25	0.013	445	1460
36	7/44	0.006	0.152	28	0.014	371	1271
34	Solid	0.0063	0.160	39.7	0.020	280	918
34	7/42	0.0075	0.192	43.8	0.022	237	777
32	Solid	0.008	0.203	67.3	0.032	174	571
32	7/40	0.008	0.203	67.3	0.034	164	538
30	Solid	0.010	0.254	100	0.051	113	365
30	7/38	0.012	0.305	112	0.057	103	339
28	Solid	0.013	0.330	159	0.080	70.8	232
28	7/36	0.015	0.381	175	0.090	64.9	213
26	Solid	0.016	0.409	256	0.128	43.6	143
26	10/36	0.021	0.533	250	0.128	41.5	137
24	Solid	0.020	0.511	404	0.205	27.3	89.4
24	7/32	0.024	0.610	448	0.229	23.3	76.4
22	Solid	0.025	0.643	640	0.324	16.8	55.3
22	7/30	0.030	0.762	700	0.357	14.7	48.4
20	Solid	0.032	0.813	1020	0.519	10.5	34.6
20	7/28	0.038	0.965	1111	0.562	10.3	33.8
18	Solid	0.040	1.020	1620	0.823	6.6	21.8
18	7/26	0.048	1.219	1770	0.902	5.9	19.2
16	Solid	0.051	1.290	2580	1.310	4.2	13.7
16	7/24	0.060	1.524	2828	1.442	3.7	12.0
14	Solid	0.064	1.630	4110	2.080	2.6	8.6
14	7/22	0.073	1.854	4480	2.285	2.3	7.6

Table 22: Maximum current vs. AWG

Wire gauge	Polyethylene Neoprene Polyvinylchloride (semi-ridged) at 80°C	Polypropylene Polyethylene (high density) at 90°C	Polyvinylchloride Nylon at 105°C	Kynar Polyethylene Thermoplastic at 125°C	Kapton Teflon Silicone at 200°C
AWG	I_{\max} (A)	I_{\max} (A)	I_{\max} (A)	I_{\max} (A)	I_{\max} (A)
30	2	3	3	3	4
28	3	4	4	5	6
26	4	5	5	6	7
24	6	7	7	8	10
22	8	9	10	11	13
20	10	12	13	14	17
18	15	17	18	20	24
16	19	22	24	26	32
14	27	30	33	40	45
12	36	40	45	50	55
10	47	55	58	70	75

Note: The table shows the current required to raise the temperature of a single insulated conductor in free air (30°C ambient) to the limits of various insulation types.

Example

What is the maximum current that can be applied to a 30 gauge Teflon wire in a room temperature environment? What will the self-heating be?

Answer

$$I_{\max} = 4A$$

$$\text{Wire temperature} = 200^{\circ}\text{C}$$

Sensor

- Thermistor
- Resistive temperature detector (RTD)
- Diode temperature characteristics
- Thermocouple (J and K)



Table 23: Temperature sensor overview

	Thermistor	RTD	Diode	Thermocouple
Temp range	-55°C < T < 150°C	-200°C < T < 850°C	-55°C < T < 150°C	-250°C < T < 1800°C
Cost	Very low	High	Low	Low
Accuracy	Good accuracy at one temperature Less accurate over full range	Excellent accuracy	Poor accuracy without calibration	Good accuracy with polynomial correction
Linearity	Very nonlinear. Follows reciprocal of logarithmic function	Fairly linear Nonlinearity < 4.5% of full scale Relatively simple quadratic function	Fairly linear slope $\approx -2\text{mV}/\text{C}$ Slope varies according to current excitation, diode type, and diode processing	Fairly linear Nonlinearity < 10% of full scale Complex 10th order polynomial
Construction	Less rugged	Depends on type (can be rugged)	Rugged	Most rugged
Output range	Typically 10s to 100s of kΩ full scale Very wide variation in resistance	18 to 390 Ω for PT100 180 to 3.9 kΩ for PT1000	0.4 to 0.8V	10s of millivolts
Applications	General purpose	Scientific and industrial	Low cost temperature monitor Low cost linear response	Industrial temperature measurement
General	Requires excitation	Requires excitation	Requires excitation	Self-powered Requires cold junction comp

Table 24: IC temperature sensor overview

	Diode	Analog IC temperature sensor	Digital IC temperature sensor	Temperature switch/thermostat
Temp range	$-55^{\circ}\text{C} < T < 150^{\circ}\text{C}$	$-55^{\circ}\text{C} < T < 150^{\circ}\text{C}$	$-55^{\circ}\text{C} < T < 150^{\circ}\text{C}$	$-55^{\circ}\text{C} < T < 150^{\circ}\text{C}$
Cost	Very low	Low	Low	Low
Accuracy	Poor accuracy without calibration	Good device accuracy without calibration. Total $T_{\text{error}} \leq 0.13^{\circ}\text{C}$.	Zero calibration required. Total T_{error} including ADC $\leq 0.1^{\circ}\text{C}$.	Zero calibration required. Total T_{error} including comparator $\leq 0.1^{\circ}\text{C}$.
Linearity	Fairly linear $\approx -2\text{mV}/^{\circ}\text{C}$. Slope varies according to current excitation, diode type, and diode processing from $-5.5\text{mV}/^{\circ}\text{C}$ to $+19.5\text{mV}/^{\circ}\text{C}$.	Fairly linear. With analog sensors a variety of slope options in the range from $-5.5\text{mV}/^{\circ}\text{C}$ to $+19.5\text{mV}/^{\circ}\text{C}$.	Direct readout of temperature value. 8 to 16 bits of resolution.	Programmable temperature threshold
Construction	Rugged	Rugged	Rugged	Rugged
Output range	0.4V to 0.8V	0 to 3V for analog. Different output ranges for different devices.	Digital interfaces: I2C, SPI, UART	Active high or active low output
Applications	Low cost temperature monitor. Low cost linear response.	General purpose, industrial and automotive	General purpose, industrial and automotive	General purpose, industrial and automotive
General	Requires excitation	No external excitation required. Analog output normally directly connected to ADC.	Integrated temperature sensor and ADC/comparator. Options to measure remote diodes.	Resistor programmable, pin programmable, factory preset

RTD equation temperature to resistance ($T \geq 0^\circ\text{C}$ and $T < 0^\circ\text{C}$)

$$R_{\text{RTD}} = R_0 \left[1 + A_0 T + B_0 T^2 + C_0 (T - 100) T^3 \right] \quad (164) \text{ RTD resistance for } T < 0^\circ\text{C}$$

$$R_{\text{RTD}} = R_0 \left[1 + A_0 T + B_0 T^2 \right] \quad (165) \text{ RTD resistance for } T \geq 0^\circ\text{C}$$

Where

R_{RTD} = resistance of RTD over temperature range of ($-200^\circ\text{C} < T < 850^\circ\text{C}$)

$R_0 = 100\Omega$ for PT-100, 1000Ω for PT-1000

A_0, B_0, C_0 = Callendar-Van Dusen coefficients

T = temperature in degrees Celsius ($^\circ\text{C}$)

RTD equation resistance to temperature ($T \geq 0^\circ\text{C}$ or $R_{\text{RTD}} \geq R_0$)

$$T = \frac{-A_0 + \sqrt{A_0^2 - 4B_0 \left(1 - \frac{R_{\text{RTD}}}{R_0} \right)}}{2B_0} \quad (166) \text{ Temperature for } T \geq 0^\circ\text{C} \text{ or } R_{\text{RTD}} \geq R_0$$

Where

R_{RTD} = resistance of RTD over temperature range of ($T \geq 0^\circ\text{C}$)

$R_0 = 100\Omega$ for PT-100, 1000Ω for PT-1000

A_0, B_0, C_0 = Callendar-Van Dusen coefficients

T = temperature in degrees Celsius ($^\circ\text{C}$)

Table 25: Callendar-Van Dusen coefficients for different RTD standards

	IEC-751 DIN 43760 BS 1904 ASTM-E1137 EN-60751	JISC 1604	US Industrial Standard D-100 American	US Industrial Standard American	ITS-90
A_0	+3.9083E-3	+3.9739E-3	+3.9787E-3	+3.9692E-3	+3.9888E-3
B_0	-5.775E-7	-5.870E-7	-5.8686E-7	-5.8495E-7	-5.915E-7
C_0	-4.183E-12	-4.4E-12	-4.167E-12	-4.233E-12	-3.85E-12

Example

What is the temperature given an ITS-90 PT100 resistance of 120Ω ?

Answer

$$T = \frac{-(3.9888 \cdot 10^{-3}) + \sqrt{(3.9888 \cdot 10^{-3})^2 - 4(-5.915 \cdot 10^{-7}) \left(1 - \frac{120}{100} \right)}}{2(-5.915 \cdot 10^{-7})} = 50.5^\circ\text{C}$$

RTD equation resistance to temperature ($T < 0^{\circ}\text{C}$ or $R_{\text{RTD}} < R_0$)

$$T = \sum_{i=0}^n \alpha_i (R_{\text{RTD}})^i \quad (167) \text{ Temperature for } T < 0^{\circ}\text{C} \text{ or } R_{\text{RTD}} < R_0$$

Where

T = temperature in degrees Celsius ($^{\circ}\text{C}$)

R_{RTD} = resistance of RTD over temperature range of ($T < 0^{\circ}\text{C}$)

α_i = polynomial coefficients for converting RTD resistance to temperature for $T < 0^{\circ}\text{C}$

Table 26: Coefficients for 5th order RTD resistance to temperature

	IEC-751 DIN 43760 BS 1904 ASTM-E1137 EN-60751	JISC 1604	US Industrial Standard D-100 American	US Industrial Standard American	ITS-90
α_0	-2.420199E+02	-2.381987E+02	-2.381832E+02	-2.386381E+02	-2.379147E+02
α_1	2.222812E+00	2.189835E+00	2.195550E+00	2.197285E+00	2.201058E+00
α_2	2.585894E-03	2.522738E-03	2.441461E-03	2.480324E-03	2.322506E-03
α_3	-4.825976E-06	-4.781625E-06	-4.751529E-06	-4.778784E-06	-4.628394E-06
α_4	-2.818583E-08	-2.704445E-08	-2.385758E-08	-2.518695E-08	-1.971986E-08
α_5	1.524399E-10	1.473912E-10	1.350936E-10	1.403820E-10	1.184331E-10

Example

Find the temperature given an ITS-90 PT100 resistance of 60 Ω .

Answer

R=60

$$T = (-2.379147\text{E}+02) + (2.201058\text{E}+00) \cdot R + (2.322506\text{E}-03) \cdot R^2 + (-4.628394\text{E}-06) \cdot R^3 + (-1.971986\text{E}-08) \cdot R^4 + (1.184331\text{E}-10) \cdot R^5 = -98.653^{\circ}\text{C}$$

Diode equation vs. temperature

$$V_D = \frac{nkT}{q} \ln\left(\frac{I}{I_S} + 1\right) \approx \frac{nkT}{q} \ln\left(\frac{I}{I_S}\right) \quad (168) \text{ Diode voltage}$$

Where

V_D = diode voltage vs. temperature and current

n = diode ideality factor (ranges from 1 to 2)

$k = 1.38 \times 10^{-23}$ J/K, Boltzmann's constant

T = temperature in Kelvin

$q = 1.60 \times 10^{-19}$ C, charge of an electron

I = forward diode current in amps

I_S = saturation current

$$I_S = \alpha T^{(3/n)} \exp\left(-\frac{qV_G}{nkT}\right) \quad (169) \text{ Saturation current}$$

Where

I_S = saturation current

α = constant related to the cross sectional area of the junction

V_G = diode voltage vs. temperature and current

n = diode ideality factor (ranges from 1 to 2)

$k = 1.38 \times 10^{-23}$ J/K, Boltzmann's constant

T = temperature in Kelvin

$q = 1.60 \times 10^{-19}$ C, charge of an electron

Diode voltage versus temperature

Figure 67 shows an example of the temperature drift for a diode. Depending on the characteristics of the diode and the forward current the slope and offset of this curve will change. However, typical diode drift is about $-2\text{mV}/^\circ\text{C}$. A forward drop of about 0.6V is typical for room temperature.

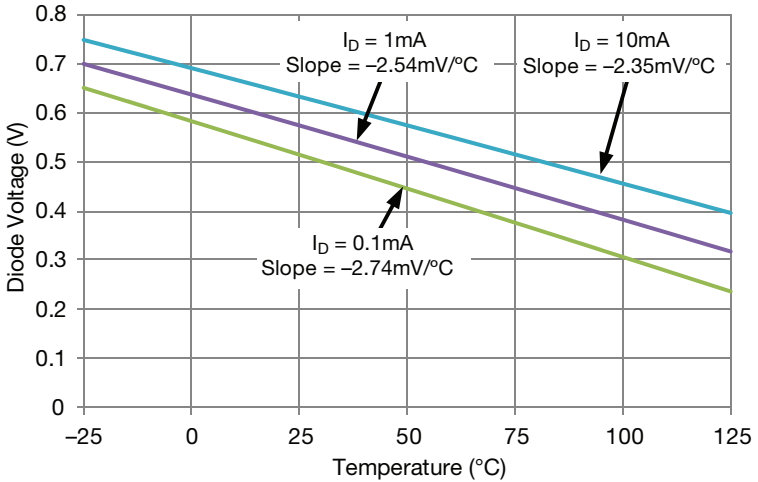

Figure 67: Diode voltage drop vs. temperature

Type J thermocouples translating temperature to voltage (ITS-90 standard)

$$V_T = \sum_{i=0}^n c_i(T)^i \quad (170) \text{ Thermoelectric voltage}$$

Where

V_T = thermoelectric voltage

T = temperature in degrees Celsius

c_i = translation coefficients

Table 27: Type J thermocouple temperature to voltage coefficients

Type J thermocouple temperature to voltage		
Temperature	-219°C to 760°C	760°C to 1,200°C
c_0	0.0000000000E+00	2.9645625681E+05
c_1	5.0381187815E+01	-1.4976127786E+03
c_2	3.0475836930E-02	3.1787103924E+00
c_3	-8.5681065720E-05	-3.1847686701E-03
c_4	1.3228195295E-07	1.5720819004E-06
c_5	-1.7052958337E-10	-3.0691369056E-10
c_6	2.0948090697E-13	—
c_7	-1.2538395336E-16	—
c_8	1.5631725697E-20	—

Type J thermocouples translating voltage to temperature (ITS-90 standard)

$$T = \sum_{i=0}^n C_i (V_t)^i \quad (171) \text{ Temperature}$$

Table 28: Type J thermocouple voltage to temperature coefficients

Type J thermocouple voltage to temperature			
Temperature	-219°C to 0°C	0°C to 760°C	760°C to 1,200°C
Voltage	-8.095mV to 0V	0V to 42.919mV	42.919mV to 69.553mV
C₀	0.000000000E+00	0.000000000E+00	-3.113581870E+03
C₁	1.952826800E-02	1.978425000E-02	3.005436840E-01
C₂	-1.228618500E-06	-2.001204000E-07	-9.947732300E-06
C₃	-1.075217800E-09	1.036969000E-11	1.702766300E-10
C₄	-5.908693300E-13	-2.549687000E-16	-1.430334680E-15
C₅	-1.725671300E-16	3.585153000E-21	4.738860840E-21
C₆	-2.813151300E-20	-5.344285000E-26	—
C₇	-2.396337000E-24	5.099890000E-31	—
C₈	-8.382332100E-29	—	—

Type K thermocouples translating temperature to voltage (ITS-90 standard)

$$V_T = \sum_{i=0}^n c_i(T)^i \quad (172) \text{ Thermoelectric voltage for } T < 0^\circ\text{C}$$

$$V_T = \left[\sum_{i=0}^n c_i(T)^i \right] + \alpha_0 e^{[\alpha_1(T-126.9686)]^2} \quad (173) \text{ Thermoelectric voltage for } T > 0^\circ\text{C}$$

Where

V_T = thermoelectric voltage

T = temperature in degrees Celsius

c_i = translation coefficients

α_0, α_1 = translation coefficients

Table 29: Type K thermocouple temperature to voltage coefficients

Temperature	-270°C to 0°C	0°C to 1,372°C
C₀	0.0000000000E+00	-1.7600413686E+01
C₁	3.9450128025E+01	3.8921204975E+01
C₂	2.3622373598E-02	1.8558770032E-02
C₃	-3.2858906784E-04	-9.9457592874E-05
C₄	-4.9904828777E-06	3.1840945719E-07
C₅	-6.7509059173E-08	-5.6072844889E-10
C₆	-5.7410327428E-10	5.6075059059E-13
C₇	-3.1088872894E-12	-3.2020720003E-16
C₈	-1.0451609365E-14	9.7151147152E-20
C₉	-1.9889266878E-17	-1.2104721275E-23
C₁₀	-1.6322697486E-20	—
α₀	—	1.1859760000E+02
α₁	—	-1.1834320000E-04

Type K thermocouples translating voltage to temperature (ITS-90 standard)

$$T = \sum_{i=0}^n C_i (V_t)^i \quad (174) \text{ Temperature}$$

Table 30: Type K thermocouple voltage to temperature coefficients

Temperature	-200°C to 0°C	0°C to 500°C	500°C to 1,372°C
Voltage	-5.891mV to 0V	0V to 20.644mV	20.644mV to 54.886mV
C₀	0.0000000E+00	0.0000000E+00	-1.3180580E+02
C₁	2.5173462E-02	2.5083550E-02	4.8302220E-02
C₂	-1.1662878E-06	7.8601060E-08	-1.6460310E-06
C₃	-1.0833638E-09	-2.5031310E-10	5.4647310E-11
C₄	-8.9773540E-13	8.3152700E-14	-9.6507150E-16
C₅	-3.7342377E-16	-1.2280340E-17	8.8021930E-21
C₆	-8.6632643E-20	9.8040360E-22	-3.1108100E-26
C₇	-1.0450598E-23	-4.4130300E-26	—
C₈	-5.1920577E-28	1.0577340E-30	—
C₉	—	-1.0527550E-35	—

Table 31: Seebeck coefficients for different material

Material	Seebeck coefficient	Material	Seebeck coefficient	Material	Seebeck coefficient
Aluminum	4	Gold	6.5	Rhodium	6
Antimony	47	Iron	19	Selenium	900
Bismuth	-72	Lead	4	Silicon	440
Cadmium	7.5	Mercury	0.6	Silver	6.5
Carbon	3	Nichrome	25	Sodium	-2.0
Constantan	-35	Nickel	-15	Tantalum	4.5
Copper	6.5	Platinum	0	Tellurium	500
Germanium	300	Potassium	-9.0	Tungsten	7.5

Note: Units are $\mu\text{V}/^\circ\text{C}$. All data at temperature of 0°C .

Thermistor: Resistance to temperature, Steinhart-Hart equation

$$\frac{1}{T} = a + b \ln(R) + c [\ln(R)]^3 \quad (175) \text{ Convert resistance to temperature for a thermistor}$$

Where

T = temperature in Kelvin

a, b, c = Steinhart-Hart equation constants

R = resistance in ohms

Thermistor: Temperature to resistance, Steinhart-Hart equation

$$R = \exp \left[\left(y - \frac{x}{2} \right)^{\frac{1}{3}} - \left(y + \frac{x}{2} \right)^{\frac{1}{3}} \right] \quad (176) \text{ Convert temperature to resistance for a thermistor}$$

$$x = \frac{a - \frac{1}{T}}{c} \quad (177) \text{ Factor used in Equation 165}$$

$$y = \sqrt{\left(\frac{b}{3c} \right)^3 + \frac{x^2}{4}} \quad (178) \text{ Factor used in Equation 165}$$

Where

R = resistance in Ω

T = temperature in Kelvin

a, b, c = Steinhart-Hart equation constants

x, y = Steinhart-Hart factors used in temperature to resistance equation

Digital

- Binary/hex conversions
- Digital logic thresholds
- Serial peripheral interface
- Inter-integrated circuit (I²C) bus

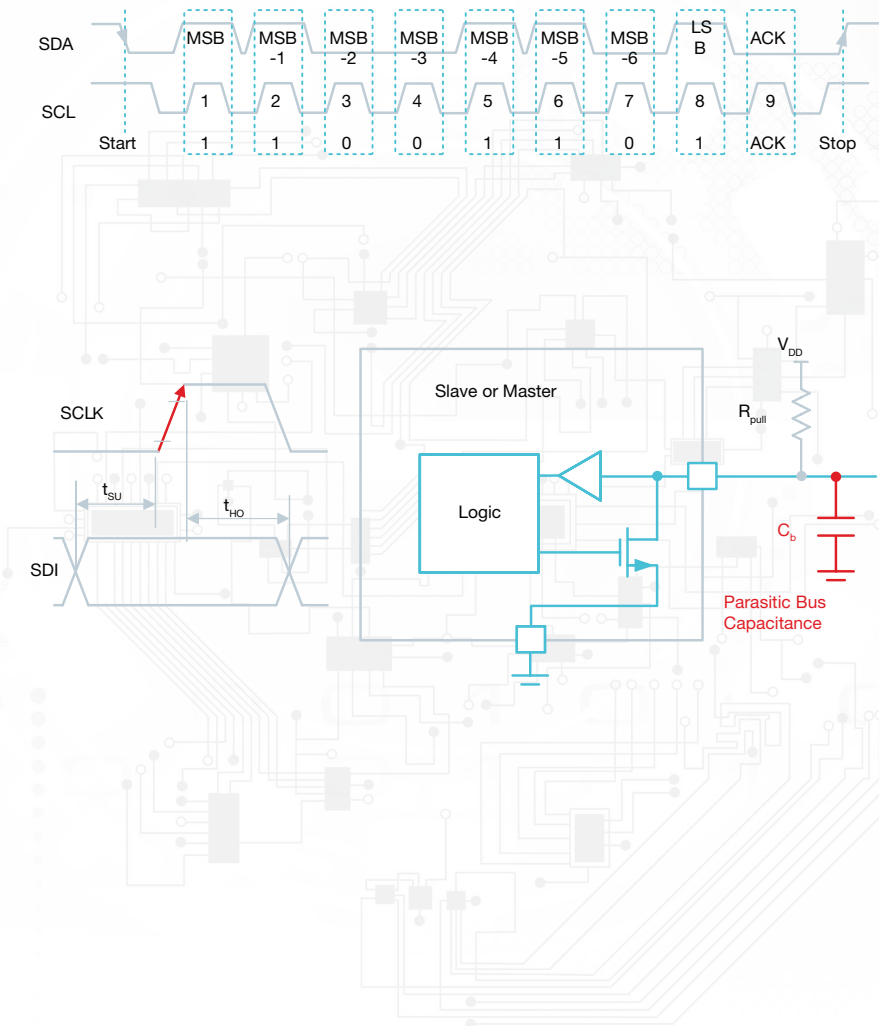

Numbering systems: Binary, decimal, and hexadecimal

Binary (Base-2)	0					1										
Decimal (Base-10)	0	1	2	3	4	5	6	7	8	9						
Hexadecimal (Base-16)	0	1	2	3	4	5	6	7	8	9	A	B	C	D	E	F

Example conversion: Binary to decimal

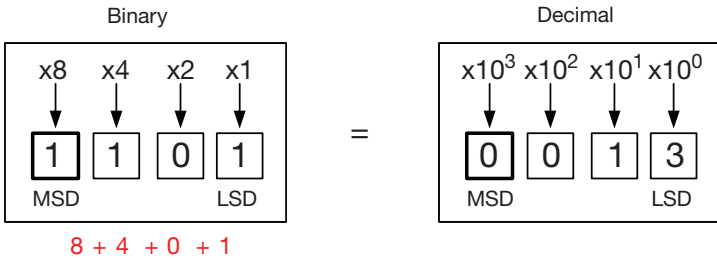

Example conversion: Decimal to binary

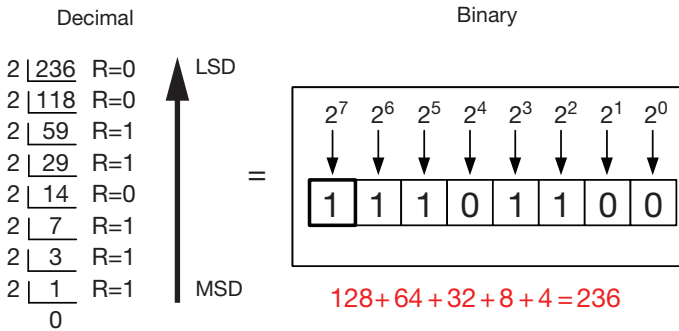

LSD = Least significant digit
 MSD = Most significant digit

Numbering systems: Binary, decimal, and hexadecimal (cont.)

Example conversion: Binary to hexadecimal

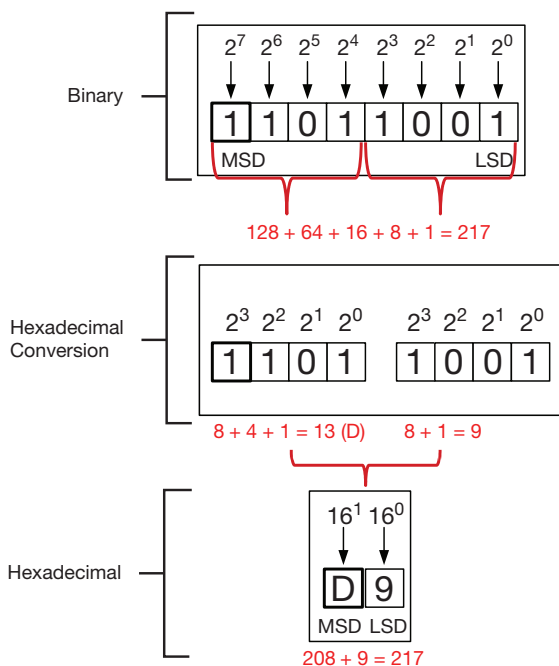

Example conversion: Hexadecimal to decimal and decimal to hexadecimal

Decimal (Base-10)	0	1	2	3	4	5	6	7	8	9	10	11	12	13	14	15
Hexadecimal (Base-16)	0	1	2	3	4	5	6	7	8	9	A	B	C	D	E	F

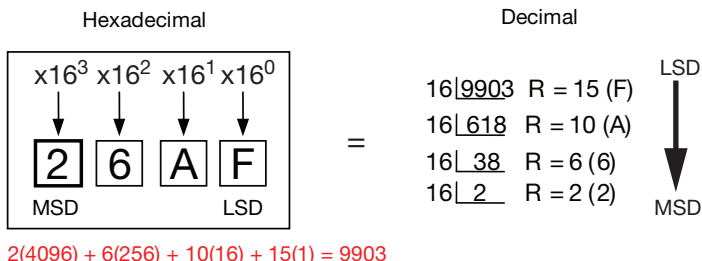

LSD = Least significant digit
MSD = Most significant digit

Data formats

Table 32: Different data formats

Code	Straight binary	Offset binary	2's complement
Binary	Decimal value	Decimal value	Decimal value
11111111	255	127	-1
11000000	192	64	-64
10000000	128	0	-128
01111111	127	-1	127
01000000	64	-64	64
00000000	0	-128	0

Converting two's complement to decimal:

Negative number example

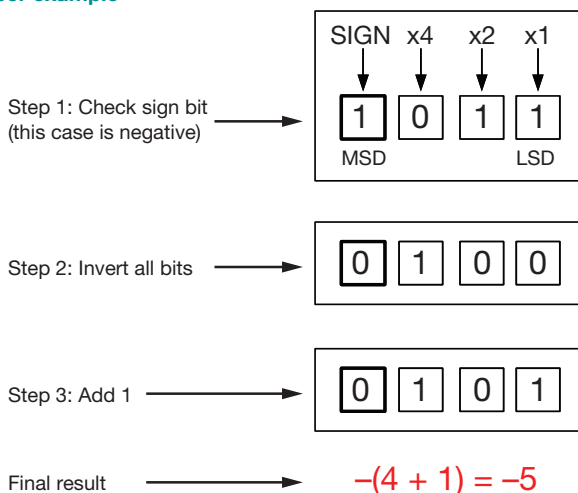

Converting two's complement to decimal:

Positive number example

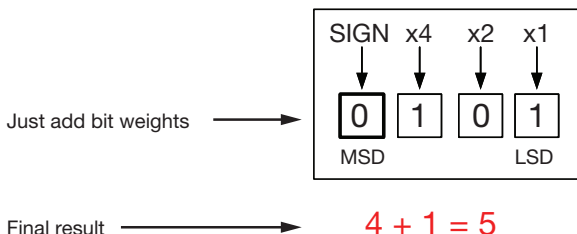

Digital logic thresholds

Input logic thresholds = the voltage range a logic device will sense a logic high or low as specified in the data sheet. Applying an input voltage outside of this range to the device will have unpredictable results.

Output logic thresholds = the output voltage range of a logic device driving a logic high or low as specified in the data sheet. The output level range is normally specified with current loads (sourcing for logic high and sinking for logic low).

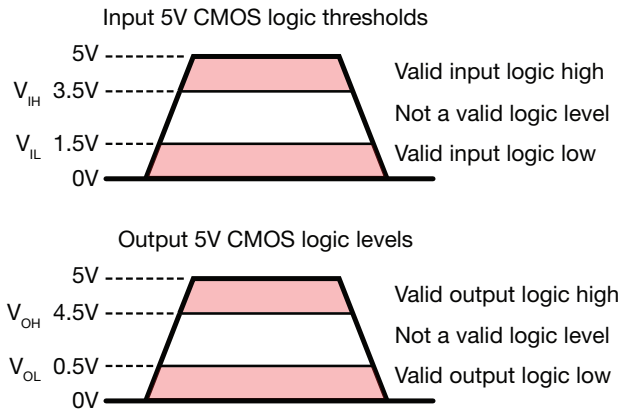

Figure 68: Valid input logic levels for 5V CMOS

Table 33: CMOS logic thresholds

	5V CMOS		3.3V CMOS		2.5V CMOS	1.8V CMOS
V_{CC}	5.0		3.3		2.5	1.8
V_{OH}	4.5	$0.9 \cdot V_{CC}$	2.97	$0.9 \cdot V_{CC}$	2.0	1.35
V_{IH}	3.5	$0.7 \cdot V_{CC}$	2.31	$0.7 \cdot V_{CC}$	1.7	1.17
V_{IL}	1.5	$0.3 \cdot V_{CC}$	0.99	$0.3 \cdot V_{CC}$	0.7	0.63
V_{OL}	0.5	$0.1 \cdot V_{CC}$	0.33	$0.1 \cdot V_{CC}$	0.4	0.45
GND	0.0		0.0		0.0	0.0

Table 34: TTL logic thresholds

	5V TTL	3.3V LVTTTL
V_{CC}	5.0	3.3
V_{OH}	2.4	2.4
V_{IH}	2.0	1.5
V_{IL}	0.8	0.8
V_{OL}	0.4	0.4
GND	0.0	0.0

Where

V_{CC} and GND = supply voltage and ground for the device

V_{OH} = minimum output logic high level

V_{IH} = minimum input high logic level

V_{IL} = maximum input logic low level

V_{OL} = maximum output logic low level

SPI bus (Serial Peripheral Interface) hardware overview

- In SPI interfaces the master can connect to one or more slave devices
- In cases when multiple slave devices are used, the master will use multiple chip select (\overline{CS}) lines

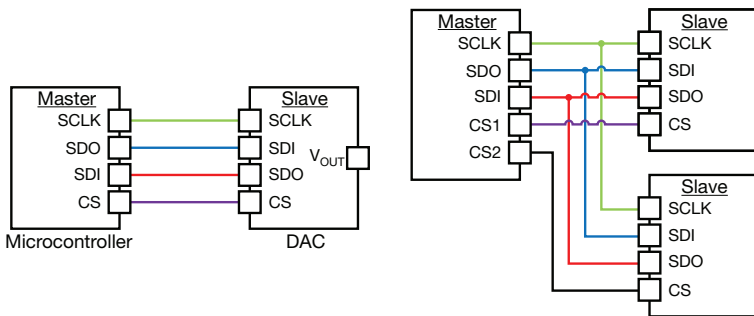

Figure 69: SPI master and slave configurations

Data and control lines

\overline{CS} (chip select) = sometimes referred to as slave select. \overline{CS} is driven by the master and arbitrates over the SPI bus. When driven low, the SPI bus is active.

SDO/SDI (serial data in and serial data out) = these names describe data flow for the device. The system names describe the data flow relationship between the master and slave. System names: MOSI = Master Out Slave In and MISO = Master In Slave Out. Example: SDO on a slave is MISO in the system and SDI is MOSI in the system.

SCLK (serial clock) = this is a square wave driven by the SPI master. Data on SDO and SDI have relative timing to the SCLK signal which controls the latching of the data on the SPI bus.

SPI data latching

- SPI data is latched on the rising or falling edge of SCLK
- The edge data is latched on is called the critical edge
- The figure below illustrates latching logic 1 on rising edge and logic 0 on falling edge



Figure 70: SPI SCLK critical edge

SPI read sequence example

1. Critical edge is rising edge
2. Master output writing to slave (SDI label relative to slave device)
3. The active low \overline{CS} pin is driven low to 0V, activating the slave SPI bus
4. Data is clocked in from MSB to LSB on the rising edge of SCLK
5. Completed SPI transaction data is binary 1011001

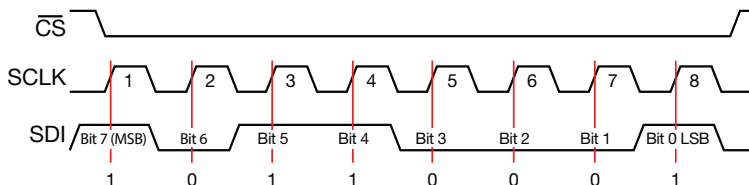

Figure 71: Example SPI write sequence

SPI critical edge

t_{SU} (setup time) = defines how long before the critical edge that the data on SDI must already be set and settled

t_{HO} (hold time) = defines how long after the critical edge data must be maintained on SDI.

t_{DO} (delay time) - defines the delay before data is valid after the critical edge for SDO.

Violation of any timing requirement could result in corruption of data.

The timing parameters, t_{SU} , t_{HO} and t_{DO} , are defined relative to the critical edge. In the example below for SDI the rising edge of SCLK is the critical edge and for SDO the falling edge of SCLK is the critical edge.

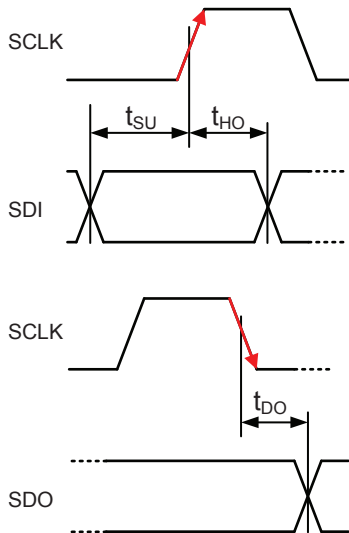

Figure 72: Setup and hold timing illustration

SPI modes

CPHA (clock phase) = defines which edge data is latched on, a 0 representing the first edge and a 1 representing the second edge

CPOL (clock polarity) = defines whether the clock idles high or low in between SPI frames. CPOL = 0 idles low, CPOL = 1 idles high.

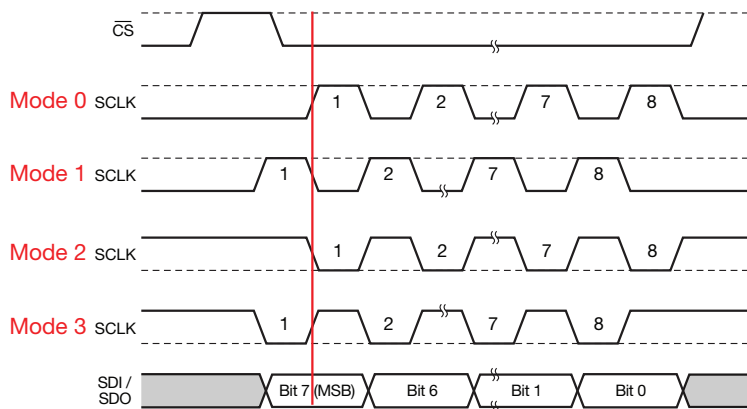

Figure 73: SPI modes of operation

Mode	CPOL	CPHA	Critical edge	Clock phase
0	0	0	Rising edge	Idles low
1	0	1	Falling edge	Idles low
2	1	0	Rising edge	Idles high
3	1	1	Falling edge	Idles high

I²C bus (Inter-Integrated Circuit) hardware overview

- On I²C buses the master can connect to one or more slave devices
- The slave is selected by its I²C address. This allows one controller to connect to many slaves on the two-wire bus.

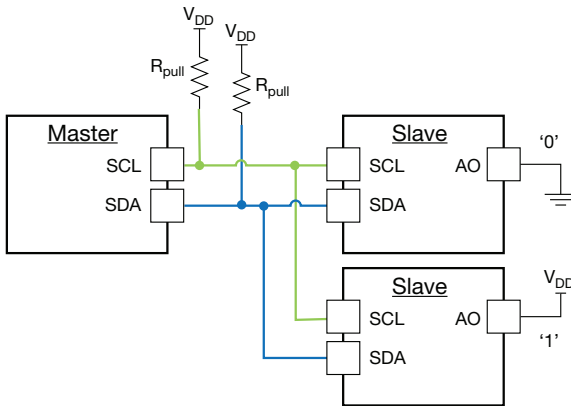

Figure 74: : I²C master and slave hardware connections

Data and control lines

SCL (serial clock) = this is a square wave driven by the master that controls how fast data is sent and when data is latched to the slave device(s)

SDA (serial data) = both master and slave place data on this line in sync with the clock pulses in a half-duplex fashion. Data on this line includes address, control, and communication data.

I²C addressing

- Typical addressing in I²C is 7-bit addressing with an additional bit for read or write indication
- Each device on the I²C bus must have a unique address
- Duplicate addresses will result in communication errors
- Some devices may have pin programmable I²C addresses

Address byte

MSB						LSB	R/ \bar{W}
1	0	0	1	1	0	A0	1/0

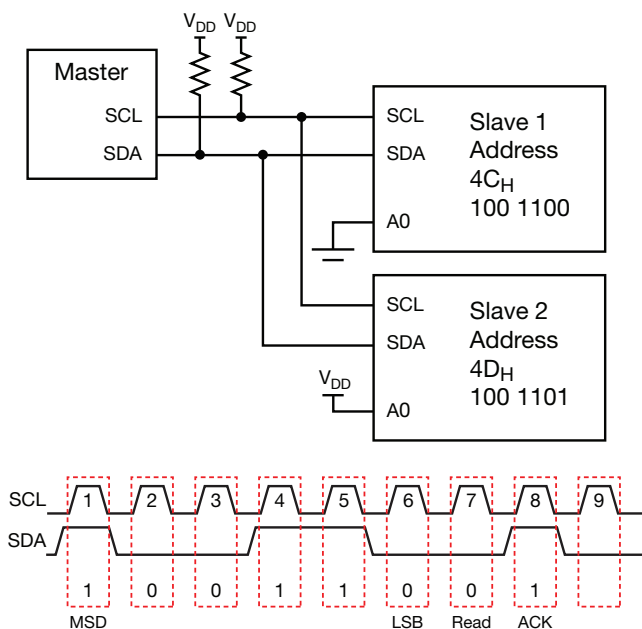

Figure 75: : I²C addressing

I²C communication

START = initiated by the master pulling SDA low while SCL is high

STOP = initiated by the master releasing the SDA pin high while SCL is high

ACK (acknowledge) = each transfer in I²C is a single byte or 8-bits, with one SCL pulse per bit. The 9th pulse in each exchange is reserved for an acknowledgement signal from the slave, or an ACK signal. The ACK signal indicates that the previous transfer was successful.

Example I²C write sequence:

1. The master pulls down SDA to generate a START condition
2. The first bit is set up and the master pulls down and releases SCL to clock data into the DAC
3. On the 9th bit the master does not pull down SDA. If the slave pulls down SDA the 8-bit transaction is acknowledged.
4. The completed transaction in binary is 11001101

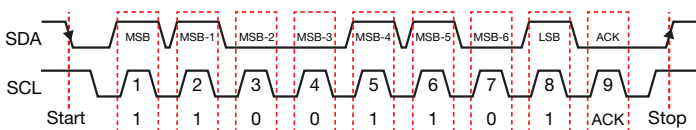

Figure 76: Complete I²C transaction

I²C communication (cont.)

For valid data transfer:

- SDA must remain stable the entire time that SCL is high for a bit transfer to be valid
- SDA is only allowed to transition in between SCL pulses when SCL is low
- Instances where SDA changes while SCL is high are interpreted as START, RESTART, or STOP conditions

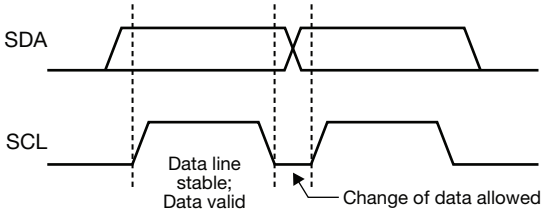

Figure 77: I²C data transfer

I²C interface circuitry and rise/fall timing

The figure below illustrates the internal structure for an I²C SCL or SDA pin. The transistor will turn on for logic low discharging C_b to logic low. The transistor will turn off for a logic high and the pull-up, R_{pull} , will charge C_b to a logic high.

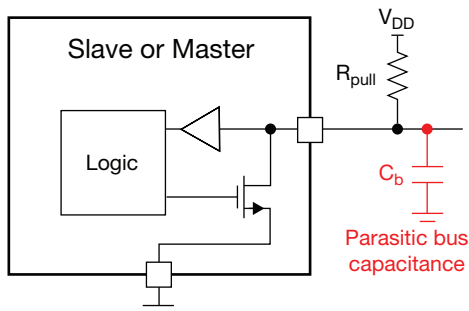

Figure 78: I²C data transfer

t_r (rise time) = the maximum amount of time for the signal to transition from logic low to logic high. Since I²C data is an open drain signal, rise time is set by the RC time constant of the pull-up resistance and the bus capacitance.

t_f (fall time) = the maximum amount of time for the signal to transition from logic high to logic low

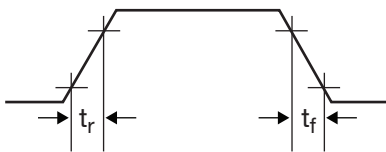

Figure 79: I²C rise and fall timing

I²C pull-up resistor selection

$$R_{\text{Pull(Min)}} = \frac{(V_{\text{DD}} - V_{\text{OLMAX}})}{I_{\text{SinkMax}}} \quad (179) \text{ Minimum I}^2\text{C pull-up resistance}$$

$$R_{\text{Pull(Max)}} = \frac{t_r}{(0.8473 \times C_b)} \quad (180) \text{ Maximum I}^2\text{C pull-up resistance}$$

Where

$R_{\text{Pull(Min)}}$ = this is the minimum pull-up resistance. This will give the shortest rise time. Using a pull-up smaller than this will draw too much current when the output transistor is on (logic low) and violate the maximum logic low output specification.

$R_{\text{Pull(Max)}}$ = maximum pull-up resistance. This will give the longest rise time. Using a pull-up resistance larger than this will violate timing requirements.

V_{DD} = supply voltage

V_{OLMAX} = maximum logic low output found in device data sheet. Typically 0.4V.

I_{SinkMax} = maximum sink current when the output transistor is on (logic low) found in device data sheet. Typically 3mA.

C_b = bus capacitance. Depends on width and length of PCB trace (see equation 155), and the capacitance of the devices connected to the bus.

Example

Find a pull-up resistor for: $V_{\text{DD}} = 5\text{V}$, $V_{\text{OLMAX}} = 0.4\text{V}$, $t_r = 300\text{ns}$, and $C_b = 100\text{pF}$.

Answer

$$R_{\text{Pull(Min)}} = \frac{(V_{\text{DD}} - V_{\text{OLMAX}})}{I_{\text{SinkMax}}} = \frac{(5\text{V} - 0.4\text{V})}{0.003\text{A}} = 1.53\text{k}\Omega$$

$$R_{\text{Pull(Max)}} = \frac{t_r}{(0.8473 \times C_b)} = \frac{300\text{ns}}{0.8473 \times 100\text{pF}} = 3.54\text{k}\Omega$$

$R_{\text{Pull}} = 2\text{k}\Omega$ Selected as a standard value between $R_{\text{Pull(Min)}}$ and $R_{\text{Pull(Max)}}$

ADC

- ADC transfer function
- Quantization error
- Signal-to-noise ratio (SNR)
- Signal-to-noise and distortion (SINAD)
- Total harmonic distortion (THD)
- Effective number of bits (ENOB)
- Noise-free resolution and effective resolution

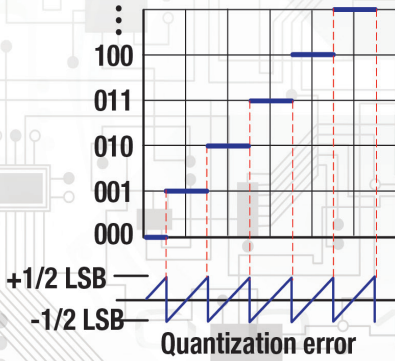
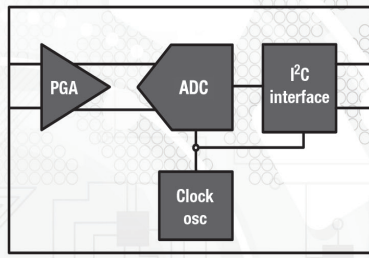

ADC definitions

Resolution = n	The number of bits used to quantify the input
Number of codes = 2^n	The number of output code combinations
Full-scale range input = FSR	Sets the converter input range and the LSB voltage
LSB = $FSR / 2^n$	The voltage step size of each LSB
Full-scale input voltage = $(2^n - 1) \cdot 1\text{LSB}$	Full-scale input voltage of the ADC
Full-scale output code = $2^n - 1$	Largest code that can be read
Transfer function: Output Code = round $[V_{IN} / (FSR/2^n)]$	Relationship between input voltage and output code

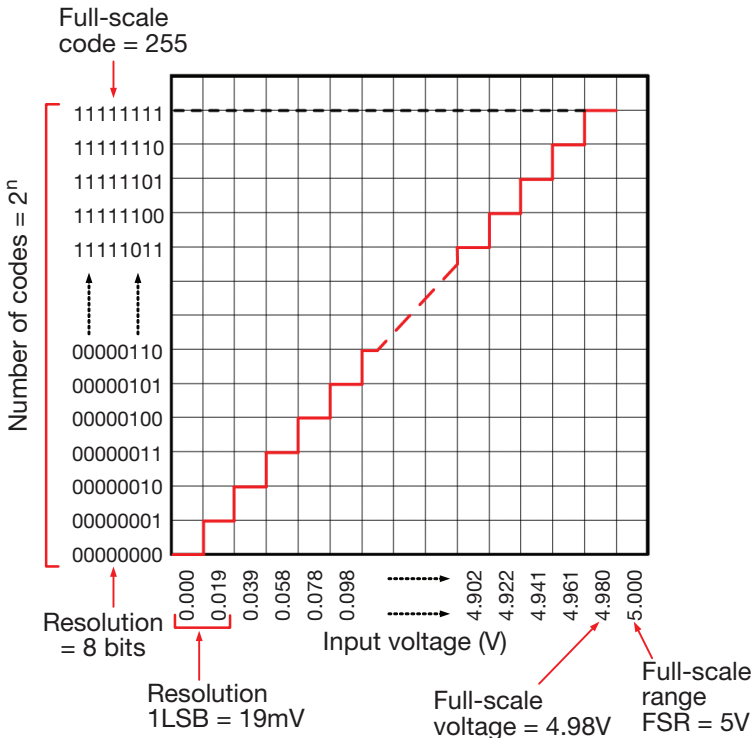

Figure 80: ADC transfer function

ADC resolution for unipolar

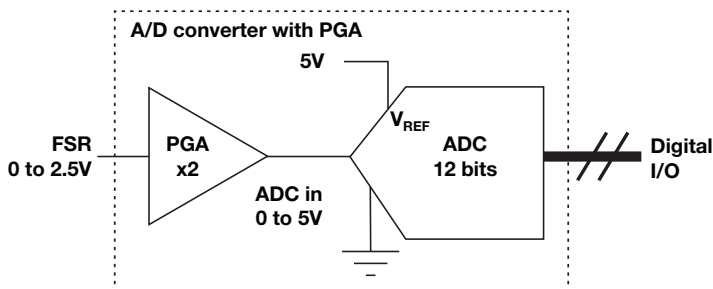

Figure 81: ADC full-scale range (FSR) unipolar

Full-scale range (FSR) unipolar

$$\text{FSR} = \frac{V_{\text{REF}}}{\text{PGA}} \quad (181) \text{ Full-scale range}$$

$$1\text{LSB} = \frac{\text{FSR}}{2^n} \quad (182) \text{ One least significant bit}$$

Where

FSR = full-scale range

PGA = PGA gain

1LSB = one least significant bit or resolution of the data converter

n = resolution number of bits

V_{REF} = reference voltage

Example calculation for the circuit above

$$\text{FSR} = \frac{V_{\text{REF}}}{\text{PGA}} = \frac{5\text{V}}{2} = 2.5\text{V}$$

$$1\text{LSB} = \frac{\text{FSR}}{2^n} = \frac{2.5\text{V}}{2^{12}} = 610.35\mu\text{V}$$

ADC resolution for bipolar

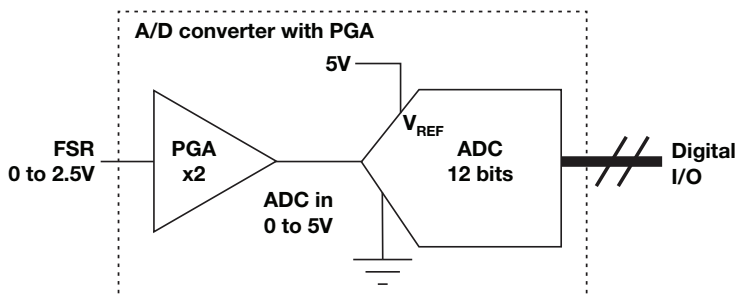

Figure 82: ADC full-scale range (FSR) bipolar

Full-scale range (FSR) bipolar

$$\text{FSR} = \frac{V_{\text{REF}}}{\text{PGA}} \quad (183) \text{ Full-scale range}$$

$$1\text{LSB} = \frac{\text{FSR}}{2^n} \quad (184) \text{ One least significant bit}$$

Where

FSR = full-scale range

PGA = PGA gain

1LSB = one least significant bit or resolution of the data converter

n = resolution number of bits

 V_{REF} = reference voltage

Example calculation for the circuit above

$$\text{FSR} = \frac{\pm V_{\text{REF}}}{\text{PGA}} = \frac{\pm 2.5\text{V}}{2} = \pm 1.25\text{V} \Rightarrow 2.5\text{V}$$

$$1\text{LSB} = \frac{\text{FSR}}{2^n} = \frac{2.5\text{V}}{2^{12}} = 610.35\mu\text{V}$$

Resolution voltage vs. full-scale range

Table 35: LSB voltage vs. resolution and reference voltage

		FSR (Full-Scale Range)			
		1.024V	1.25V	2.048V	2.5V
Resolution	8	4 mV	4.88 mV	8 mV	9.76 mV
	10	1 mV	1.22 mV	2 mV	2.44 mV
	12	250 μ V	305 μ V	500 μ V	610 μ V
	14	52.5 μ V	76.3 μ V	125 μ V	152.5 μ V
	16	15.6 μ V	19.1 μ V	31.2 μ V	38.14 μ V
	18	3.91 μ V	4.77 μ V	7.81 μ V	9.53 μ V
	20	0.98 μ V	1.19 μ V	1.95 μ V	2.384 μ V
	22	244 nV	299 nV	488 nV	596 nV
	24	61 nV	74.5 nV	122 nV	149 nV

Table 36: LSB voltage vs. resolution and reference voltage

		FSR (Full-Scale Range)			
		3V	3.3V	4.096V	5V
Resolution	8	11.7 mV	12.9 mV	16 mV	19.5 mV
	10	2.93 mV	3.222 mV	4 mV	4.882 mV
	12	732 μ V	806 μ V	1 mV	1.221 mV
	14	183 μ V	201 μ V	250 μ V	305 μ V
	16	45.77 μ V	50.35 μ V	62.5 μ V	76.29 μ V
	18	11.44 μ V	12.58 μ V	15.6 μ V	19.07 μ V
	20	2.861 μ V	3.147 μ V	3.91 μ V	4.768 μ V
	22	715 nV	787 nV	976 nV	1.192 μ V
	24	179 nV	196 nV	244 nV	298 nV

Quantization error of ADC

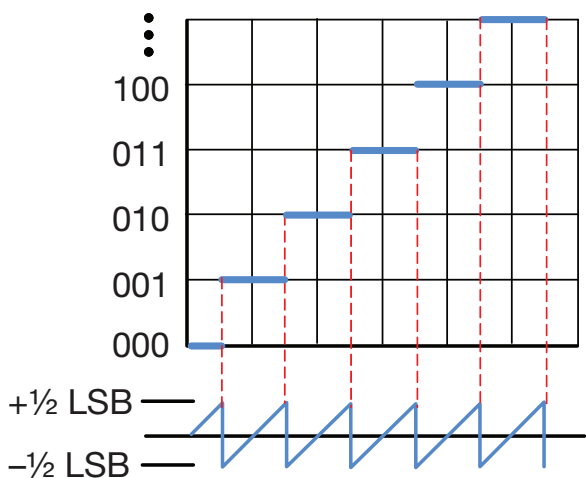

Figure 83: Quantization error of an ADC converter

Quantization error

The error introduced as a result of the quantization process. The amount of this error is a function of the resolution of the converter. The quantization error of an ADC converter is $1/2$ LSB. The quantization error signal is the difference between the actual voltage applied and the ADC output (Figure 83). The RMS of the quantization signal is $1\text{LSB}/\sqrt{12}$.

Signal-to-noise ratio (SNR) from quantization noise only

$$\text{MaxRMSSignal} = \frac{\text{FSR} / 2}{\sqrt{2}} = \frac{1 \text{ LSB} \times 2^{N-1}}{\sqrt{2}} \quad (185)$$

$$\text{RMSNoise} = \frac{1 \text{ LSB}}{\sqrt{12}} \quad \text{from quantization only} \quad (186)$$

$$\text{SNR} = \frac{\text{MaxRMSSignal}}{\text{RMSNoise}} = \frac{1 \text{ LSB} \times 2^{N-1} / \sqrt{2}}{1 \text{ LSB} / \sqrt{12}} = 2^{N-1} \sqrt{6} \quad (187)$$

$$\text{SNR(dB)} = 20 \log(\text{SNR}) = [20 \log(2)]N + 20 \log\left(\frac{\sqrt{6}}{2}\right) \quad (188)$$

$$\text{SNR(dB)} \approx 6.02N + 1.76 \quad (189)$$

Where

FSR = full-scale range of the ADC converter

1LSB = the voltage of 1LSB, $V_{\text{REF}}/2^N$

N = the resolution of the ADC converter

MaxRMSSignal = the RMS equivalent of the ADC's full-scale input

RMSNoise = the RMS noise from quantization

SNR = the ratio of RMS signal to RMS noise

Example

What is the SNR for an 8-bit ADC converter with 5V reference, assuming only quantization noise?

Answer

$$\text{SNR} = 2^{N-1} \sqrt{6} = 2^{8-1} \sqrt{6} = 314$$

$$\text{SNR(dB)} = 20 \log(314) = 49.9 \text{ dB}$$

$$\text{SNR(dB)} = 6.02(8) + 1.76 = 49.9 \text{ dB}$$

Total harmonic distortion (V_{RMS})

$$\text{THD}(\%) = \left(\frac{\text{RMSDistortion}}{\text{MaxRMSSignal}} \right) \cdot 100 = \frac{\sqrt{V_2^2 + V_3^2 + V_4^2 + \dots + V_n^2}}{V_1} \cdot 100 \quad (190)$$

$$\text{THD}(\text{dB}) = 20 \log \left(\frac{\text{RMSDistortion}}{\text{MaxRMSSignal}} \right) \quad (191)$$

Where

THD = Total Harmonic Distortion, the ratio of the RMS distortion to the RMS signal

RMSDistortion = the RMS sum of all harmonic components

MaxRMSSignal = the RMS value of the input signal

V_1 = the fundamental, generally the input signal

$V_2, V_3, V_4, \dots, V_n$ = harmonics of the fundamental

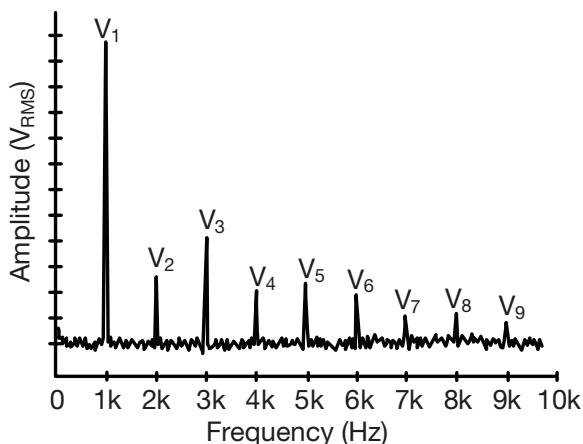

Figure 84: Fundamental and harmonics in V_{RMS}

Total harmonic distortion (dBc)

$$\text{THD(dBc)} = 10 \log \left[10^{\left(\frac{D_2}{10}\right)} + 10^{\left(\frac{D_3}{10}\right)} + 10^{\left(\frac{D_4}{10}\right)} + \dots + 10^{\left(\frac{D_n}{10}\right)} \right] \quad (192)$$

Where

THD = Total Harmonic Distortion. The ratio of the RMS distortion to the RMS signal.

D_1 = the fundamental, generally the input signal. This is normalized to 0 dBc.

$D_2, D_3, D_4, \dots, D_n$ = harmonics of the fundamental measured relative to the fundamental

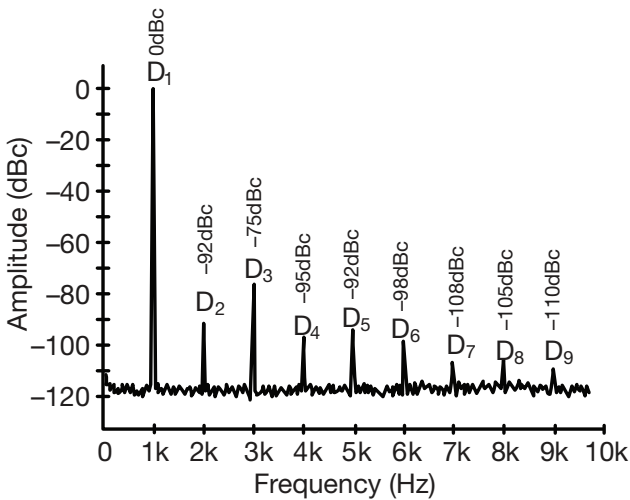

Figure 85: Fundamental and harmonics in dBc

Example

Determine THD for the example above.

Answer

$$\text{THD(dBc)} = 10 \log \left[10^{\left(\frac{-92}{10}\right)} + 10^{\left(\frac{-75}{10}\right)} + 10^{\left(\frac{-95}{10}\right)} + \dots + 10^{\left(\frac{-110}{10}\right)} \right]$$

$$\text{THD(dBc)} = -74.76 \text{ dB}$$

AC signals

Signal-to-noise and distortion (SINAD) and effective number of bits (ENOB)

$$\text{SINAD(dB)} = 20 \log \left(\frac{\text{MaxRMSSignal}}{\sqrt{\text{RMSNoise}^2 + \text{RMSDistortion}^2}} \right) \quad (193)$$

$$\text{SINAD(dB)} = -20 \log \left(\sqrt{10^{\left(\frac{-\text{SNR(dB)}}{10}\right)} + 10^{\left(\frac{\text{THD(dB)}}{10}\right)}} \right) \quad (194)$$

$$\text{ENOB} = \frac{\text{SINAD(dB)} - 1.76\text{dB}}{6.02} \quad (195)$$

Where

MaxRMSSignal = the RMS equivalent of the ADC's full-scale input

RMSNoise = the RMS noise integrated across the ADC converters

RMSDistortion = the RMS sum of all harmonic components

SINAD = the ratio of the full-scale signal-to-noise ratio and distortion

THD = Total Harmonic Distortion. The ratio of the RMS distortion to the RMS signal.

SNR = the ratio of RMS signal to RMS noise

Example

Calculate the SNR, THD, SINAD and ENOB given the following information:

MaxRMSSignal = $1.76 V_{\text{RMS}}$

RMSDistortion = $50 \mu V_{\text{RMS}}$

RMSNoise = $100 \mu V_{\text{RMS}}$

Answer

$$\text{SNR(dB)} = 20 \log \left(\frac{1.76 V_{\text{RMS}}}{100 \mu V_{\text{RMS}}} \right) = 84.9 \text{ dB}$$

$$\text{THD(dB)} = 20 \log \left(\frac{50 \mu V_{\text{RMS}}}{1.76 V_{\text{RMS}}} \right) = -90.9 \text{ dB}$$

$$\text{SINAD(dB)} = 20 \log \left(\frac{1.76 V_{\text{RMS}}}{\sqrt{(100 \mu V_{\text{RMS}})^2 + (50 \mu V_{\text{RMS}})^2}} \right) = 83.9 \text{ dB}$$

$$\text{SINAD(dB)} = -20 \log \left(\sqrt{10^{\left(\frac{-84.9 \text{ dB}}{10}\right)} + 10^{\left(\frac{-90.9 \text{ dB}}{10}\right)}} \right) = 83.9 \text{ dB}$$

$$\text{ENOB} = \frac{83.9\text{dB} - 1.76\text{dB}}{6.02} = 13.65$$

DC signals

Noise free resolution and effective resolution

$$\text{NoiseFreeResolution} = \log_2 \left(\frac{2^N}{\text{PeaktoPeakNoiseinLSB}} \right) \quad (196)$$

$$\text{EffectiveResolution} = \log_2 \left(\frac{2^N}{\text{rmsNoiseinLSB}} \right) \quad (197)$$

$$\text{PeaktoPeakNoiseinLSB} \approx 6.6 \times \text{rmsNoiseinLSB} \quad (198)$$

$$\text{EffectiveResolution} \approx \text{NoiseFreeResolution} + 2.7 \quad (199)$$

Note: The maximum effective resolution is never greater than the ADC resolution. For example, a 24-bit converter cannot have an effective resolution greater than 24 bits.

Example

What is the noise-free resolution and effective resolution for a 24-bit converter assuming the peak-to-peak noise is 7 LSBs?

Answer

$$\text{NoiseFreeResolution} = \log_2 \left(\frac{2^{24}}{7} \right) = 21.2$$

$$\text{EffectiveResolution} = \log_2 \left(\frac{2^{24}}{6.6} \right) = 23.9$$

$$\text{EffectiveResolution} = 21.2 + 2.7 = 23.9$$

Settling time and conversion accuracy

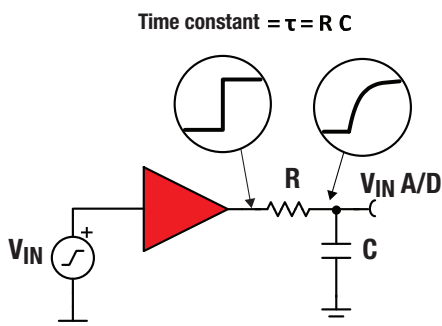

Figure 86: Settling time for RC circuit-related to ADC converters

Table 37: Conversion accuracy achieved after a specified time

Settling time in time constants (N_{TC})	Accuracy in bits (N)	Settling time in time constants (N_{TC})	Accuracy in bits
1	1.44	10	14.43
2	2.89	11	15.87
3	4.33	12	17.31
4	5.77	13	18.76
5	7.21	14	20.20
6	8.66	15	21.64
7	10.10	16	23.08
8	11.54	17	24.53
9	12.98	18	25.97

$$N = \log_2(e^{-N_{TC}}) \quad (200)$$

Where

N = the number of bits of accuracy the RC circuit has settled to after N_{TC} number of time constants

N_{TC} = the number of RC time constants. Where one time constant equals R-C.

Note: For a FSR step. For single-ended input ADC with no PGA front end, FSR (full-scale range) = V_{REF} .

Settling time and conversion accuracy (cont.)

Table 38: Time required to settle to a specified conversion accuracy

Accuracy in bits (N)	Settling time in time constants (N_{TC})	Accuracy in bits (N)	Settling time in time constants (N_{TC})
8	5.5	17	11.78
9	6.24	18	12.48
10	6.93	19	13.17
11	7.62	20	13.86
12	8.32	21	14.56
13	9.01	22	15.25
14	9.70	23	15.94
15	10.40	24	16.64
16	11.04	25	17.33

$$N_{TC} = \ln(2^N) \quad (201)$$

Where

N_{TC} = the number of time constants required to achieve N bits of settling. Where one time constant equals $R \cdot C$.

N = the number of bits of accuracy

Note: For a FSR step. For single-ended input ADC with no PGA front end, FSR (full-scale range) = V_{REF} .

ADC system noise calculation

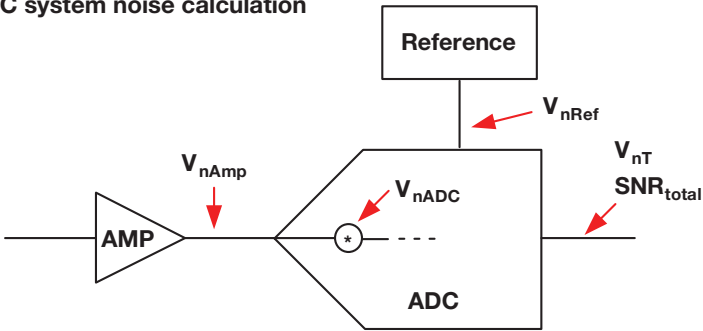

Figure 87: ADC noise

$$V_{FSR_RMS} = \frac{V_{FSR} \cdot 0.707}{2} \quad (202) \text{ Full-scale RMS input}$$

$$SNR_{ADC} = 20 \cdot \log\left(\frac{V_{FSR_RMS}}{V_{nADC}}\right) \quad (203) \text{ Solve for noise}$$

$$V_{nADC} = \frac{V_{FSR_RMS}}{10^{\left(\frac{SNR_{ADC}}{20}\right)}} \quad (204) \text{ From ADC data sheet}$$

$$V_{nT} = \sqrt{(V_{nADC})^2 + (V_{nAmp})^2 + (V_{nRef})^2} \quad (205) \text{ Total RMS noise}$$

Where

V_{FSR} = the ADC full scale range from the data sheet

V_{FSR_RMS} = this finds the maximum RMS amplitude of a sine wave applied to an ADC. Dividing the ADC full scale range by 2 converts peak-to-peak to peak. Multiplying by 0.707 converts to RMS.

SNR_{ADC} = Data converter signal to noise ratio specification from data sheet

V_{nADC} = noise in volts RMS derived from the SNR equation. Converting noise to volts allows it to be combined with amplifier and reference noise.

V_{nAmp} = amplifier noise in volts RMS calculated or simulated using data sheet parameters

V_{nRef} = reference noise in volts RMS calculated or simulated using data sheet parameters

V_{nT} = total noise in volts RMS calculated by combining ADC, amplifier, and reference noise

Effect of clock jitter on ADC SNR

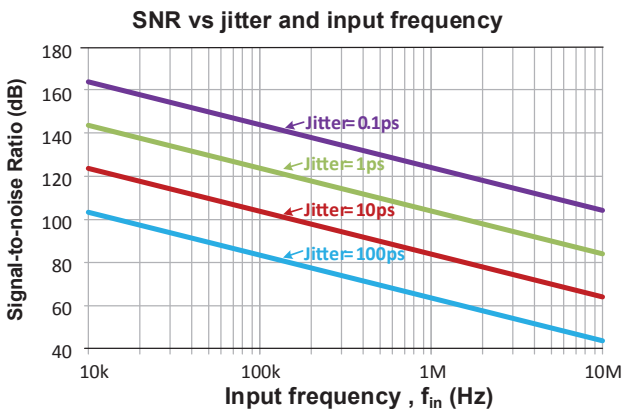

Figure 88: SNR vs jitter and input frequency

$$\text{SNR} = -20 \cdot \log(2 \cdot \pi \cdot f_{in} \cdot t_{\text{jitter}}) \quad (206) \text{ From ADC data sheet}$$

$$\text{SNR} = -20 \cdot \log(2 \cdot \pi \cdot f_{in} \cdot t_{\text{jitter}}) + 10 \cdot \log(\text{OSR}) \quad (207) \text{ SNR limitation from jitter including oversampling}$$

Where

f_{in} = input frequency (Hz)

t_{jitter} = ADC clock jitter time (seconds)

OSR = oversampling ratio

DAC

- DAC errors
- DAC non-linearity
- DAC total unadjusted error

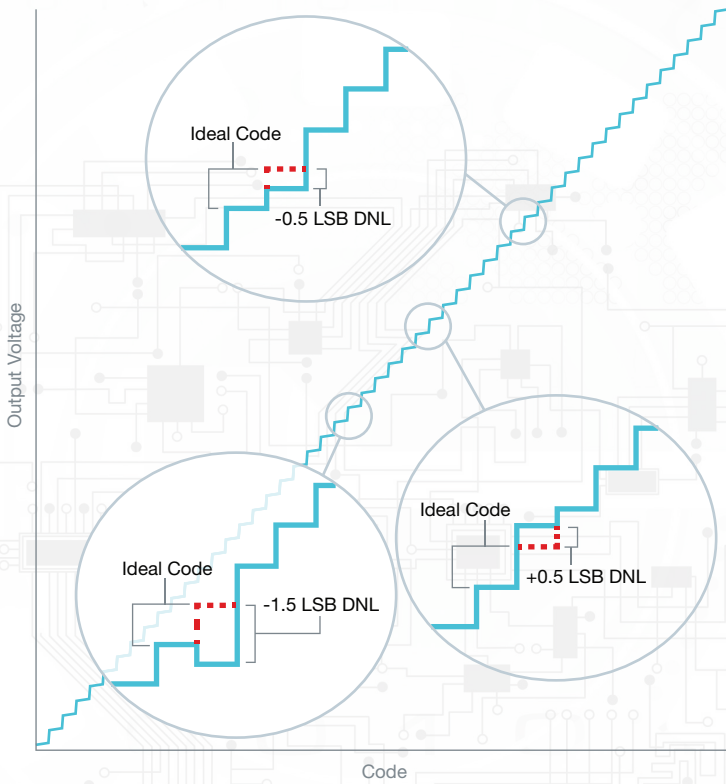

DAC definitions

Resolution = n	The number of bits used to quantify the output
Number of codes = 2^n	The number of input code combinations
Full-scale range output = FSR	Sets the converter output range and the LSB voltage
LSB = $FSR / 2^n$	The voltage step size of each LSB
Full-scale output voltage = $(2^n - 1) \times 1LSB$	Full-scale output voltage of the DAC
Full-scale input code = $2^n - 1$	Largest code that can be written
Transfer function: $V_{OUT} = \text{number of codes} \times (FSR/2^n)$	Relationship between output voltage and input code

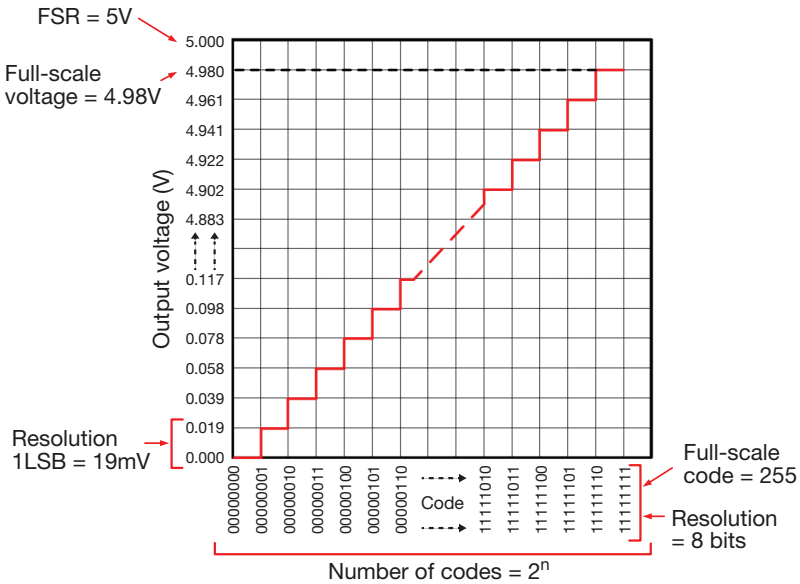

Figure 89: DAC transfer function

DAC offset error

Offset error is the y-axis intercept based on a two-point best fit measurement extrapolated to a zero input code. This is different from zero code error which is measured with Code = 0H and includes the nonlinear effects as the DAC output approaches zero volts.

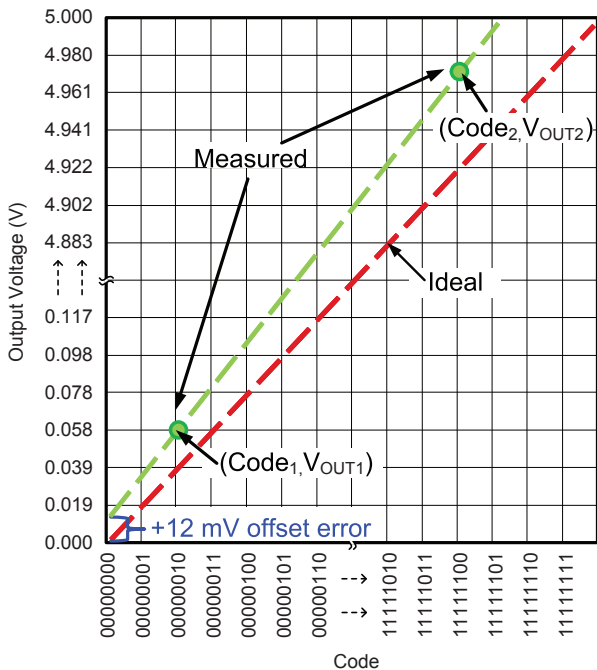

Figure 90: Offset error illustration

$$V_{OUT} = m_m \cdot \text{Code} + \text{Offset} \quad (208) \text{ General equation for best fit line}$$

$$m_m = \frac{V_{OUT2} - V_{OUT1}}{\text{Code}_2 - \text{Code}_1} \quad (209) \text{ Measured slope}$$

$$\text{Offset} = V_{OUT1} - m_m \cdot \text{Code}_1 \quad (210) \text{ Offset}$$

Where

V_{OUT} = DAC output voltage

m_m = measured slope

Code = input digital code

Offset = the offset of a best fit line

DAC gain error

Gain error describes the deviation from the ideal slope of the DAC transfer function. Similar to offset error, this specification is measured at the DAC output using a two-point line of best fit, which is then compared against the ideal gain and expressed in a percentage.

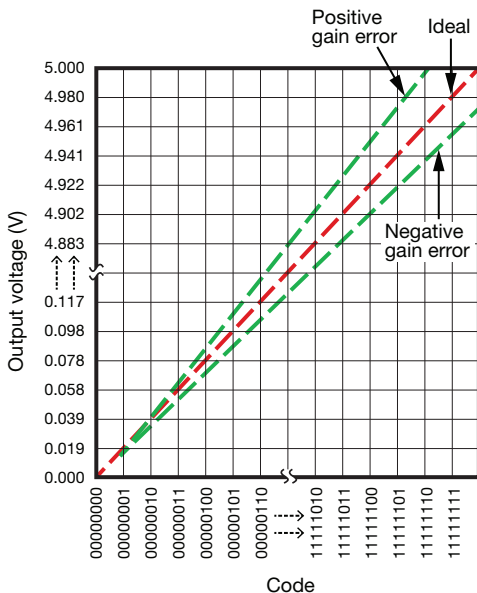

Figure 91: Gain error illustration

$$V_{OUT} = m_m \cdot \text{Code} + \text{Offset} \quad (211) \text{ General equation for best fit line}$$

$$m_m = \frac{V_{OUT2} - V_{OUT1}}{\text{Code}_2 - \text{Code}_1} \quad (212) \text{ Measured slope}$$

$$GE = \left(\frac{m_m - m_{ideal}}{m_{ideal}} \right) \cdot 100 \quad (213) \text{ Gain error in percentage}$$

Where

V_{OUT} = DAC output voltage

m_m = measured slope

Code = input digital code

Offset = the offset of a best fit line

Note: $(\text{Code}_1, V_{OUT1})$ and $(\text{Code}_2, V_{OUT2})$ are two data points on the measured transfer function. See Figure 90.

DAC zero-code error / negative full-scale error

Zero-code error (sometimes called negative full-scale error) is an end-point error measured when all 0's are loaded into the DAC data register. For a DAC with bipolar outputs, this may also be called negative full-scale error. The intention is to describe how close to the negative rail the DAC output can get when set to the minimal output value. Zero-code error is different from offset error in that it includes the potentially nonlinear output swing limitations, whereas the offset error is the offset of the best fit transfer function. The specified test conditions will indicate what, if any, negative supply was used to help assess the swing to ground capability at zero code.

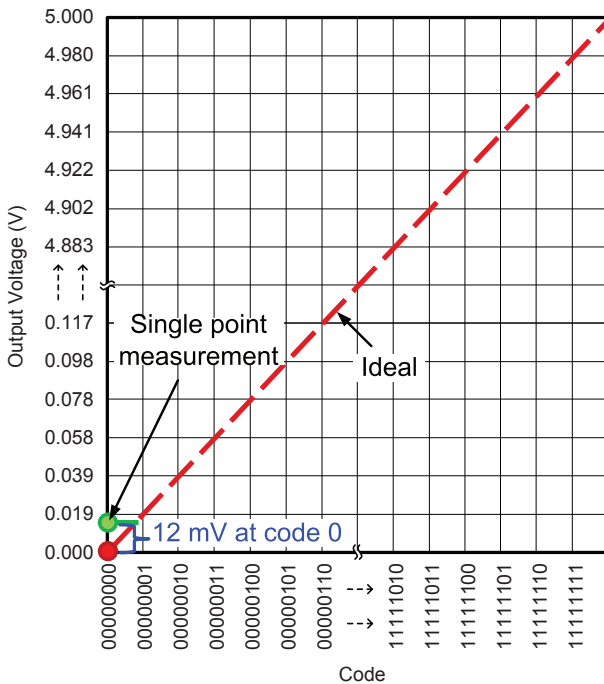

Figure 92: Zero-code error illustration

DAC bipolar zero error

Bipolar zero error is a special datasheet parameter reserved for DACs with bipolar voltage or current outputs. It describes the DAC error when set to mid-scale, assuming a symmetrical output span, where the ideal DAC should be 0V or 0A. This specification is the mid-scale combination of both offset and gain errors. The specification is arrived at based on statistical analysis and, therefore, mathematically the summation of offset and gain errors may not match this value exactly.

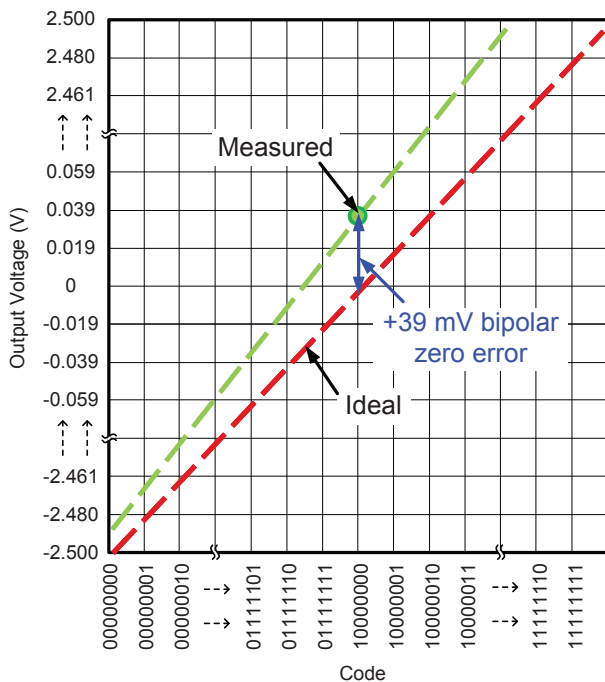

Figure 93: Bipolar zero error illustration

DAC full-scale error

Full-scale error is an end-point error measured when all 1's are loaded into the DAC data register. The intention is to describe how close to the positive rail the DAC output can get when set to the maximum output value. The specified test conditions will indicate what positive supply was used.

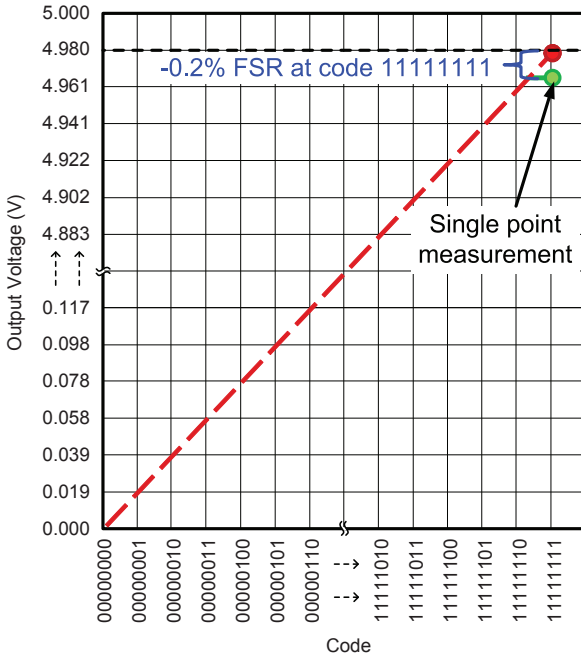

Figure 94: Full-scale error illustration

DAC differential non-linearity

Differential non-linearity, or commonly abbreviated DNL, describes the actual measured step sizes versus ideal and is expressed in terms of least significant bits or LSBs. The electrical characteristics table of a DAC datasheet will only express a single minimum and maximum value, expressing the worst case observed across every code in the linear region of the DAC transfer function. When near the positive or negative rails, especially outside of the ranges defined by the high-code and low-code used to measure offset and gain errors, DNL performance will be degraded due to saturation near the rails. Most modern DACs are monotonic meaning that the output voltage will always increase as input codes increase. Figure 95 shows both monotonic and non-monotonic DNL.

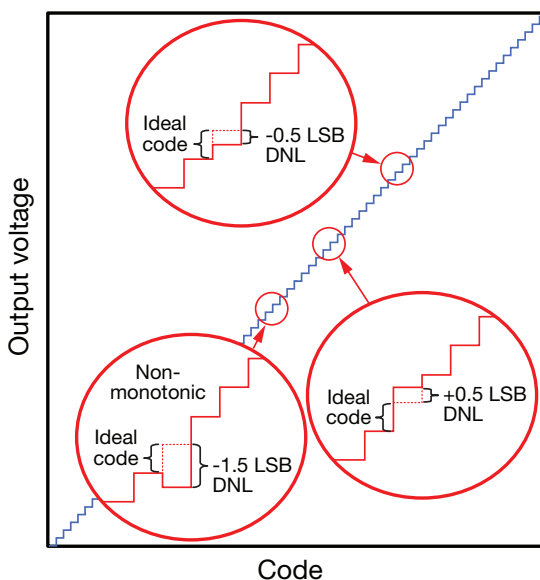

Figure 95: DNL error illustration

DAC integral non-linearity

INL (Integral Non-Linearity) is sometimes referred to as relative accuracy. This is the deviation of the transfer function from an end point fit. While DNL describes the relationship of actual code step-sizes to ideal, INL expresses the cumulative effects of sequential DNL errors. INL is the maximum deviation from an end point fit straight line. This error source cannot be corrected using a simple two point fit calibration.

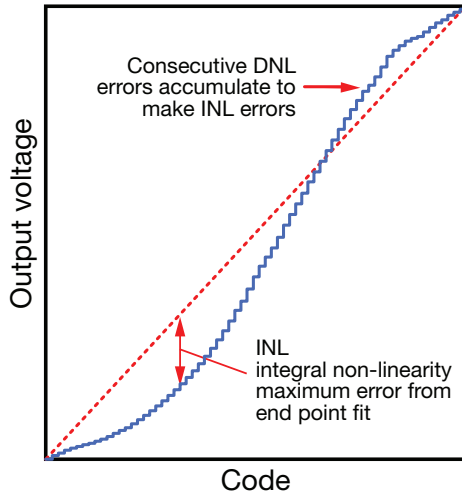

Figure 96: INL error illustration

DAC total unadjusted error

The equation below is for the total unadjusted error (or TUE). TUE is the statistical combinations of error sources in the linear region of operation for the DAC. In order to perform the above TUE calculation it is necessary to have each of the parametric error sources in the same units. Table 7 shows the calculations required to convert to different units (e.g. from percentage to parts per million).

$$\text{TUE} = \sqrt{\text{OffsetError}^2 + \text{GainError}^2 + \text{INLError}^2} \quad (214) \text{ Gain error in percentage}$$

Where

OffsetError = the offset of a best fit line through the transfer function. See Figure 90.

GainError = the difference between the ideal slope and the measured slope.
See Figure 91.

INLError = the maximum deviation from a best fit line through the transfer function.
See Figure 96.

Multiplexer

- CMOS switch construction •
- ON-resistance •
- ON and OFF capacitance •
- Leakage current •
- Charge injection •
- Bandwidth •
- Channel-to-channel crosstalk •
- OFF-isolation •
- Total harmonic distortion plus noise •

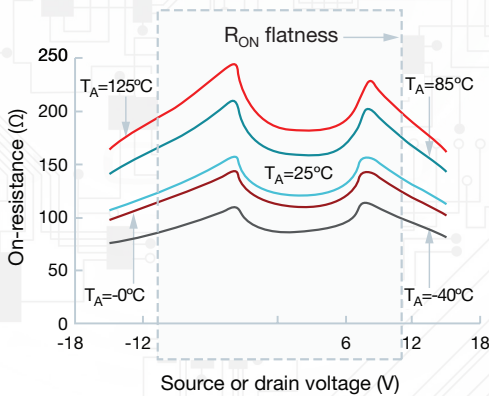
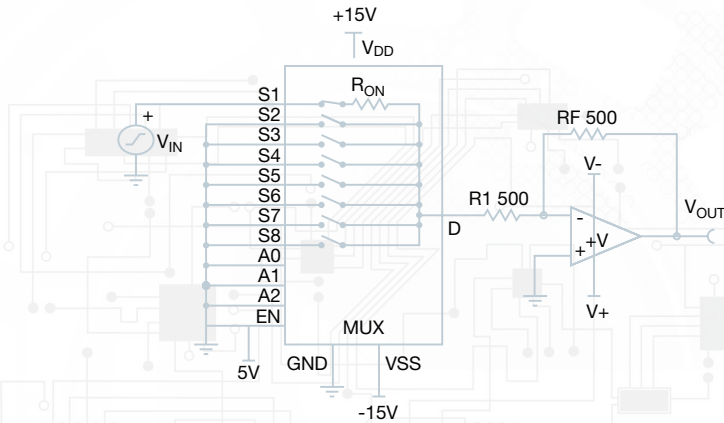

CMOS switch construction

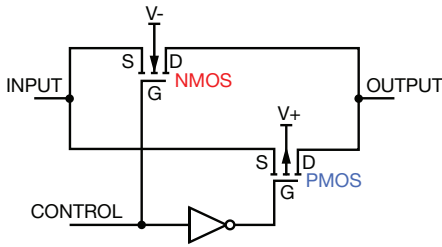

Figure 97: Typical CMOS switch construction

Typical CMOS switch elements

- Parallel combination of N channel and P channel FET
- Control signal that controls the state of the switch

ON-resistance (R_{ON})

Resistance between sources to drain terminal when switch is closed

- PMOS conducts for positive input voltages
- NMOS conducts for negative input voltages
- Combined RON is lower than individual resistance of the NMOS or PMOS that form the switch

Varies with

- MUX input voltage
- Operating ambient temperature

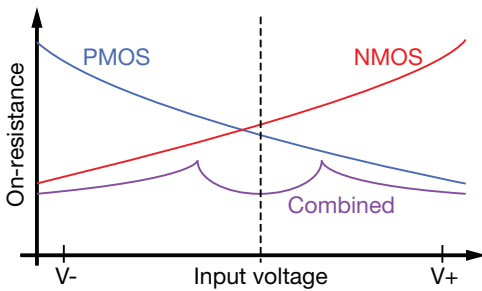

Figure 98: Typical MUX ON-resistance curve vs input voltage

R_{ON} flatness

Difference between maximum and minimum ON-resistance over a specified input range

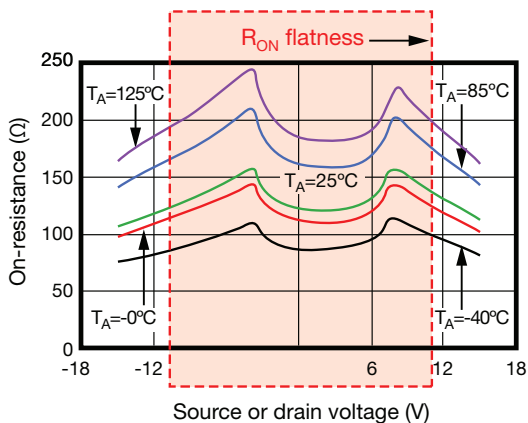

Figure 99: R_{ON} flatness illustration

Effective op amp gain including MUX R_{ON}

This section shows the impact of R_{ON} flatness on gain error and non-linearity. Figure 99 shows the circuit and Figure 100 shows the measured results.

$$AG = \frac{V_{OUT}}{V_{IN}} = \frac{-RF}{(R1 + R_{ON})}$$

(215) Effective gain for op amp with MUX

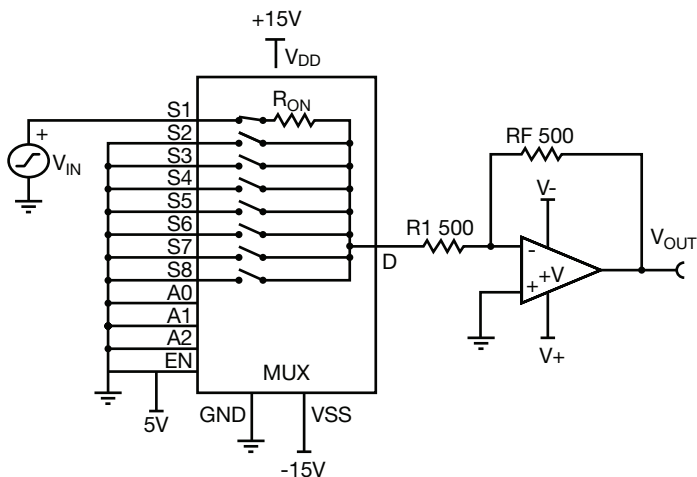

Figure 100: Front-end MUX followed by an inverting amplifier stage

Effective op amp gain including MUX R_{ON} (cont.)

Figure 101: Effect of varying R_{ON} causing gain error and non-linearity

Design tips

- Use high impedance stage between MUX output and signal conditioning
- Use a multiplexer with lower R_{ON} (at the expense of other design trade-offs)

ON and OFF capacitance (C_{ON} / C_{OFF})

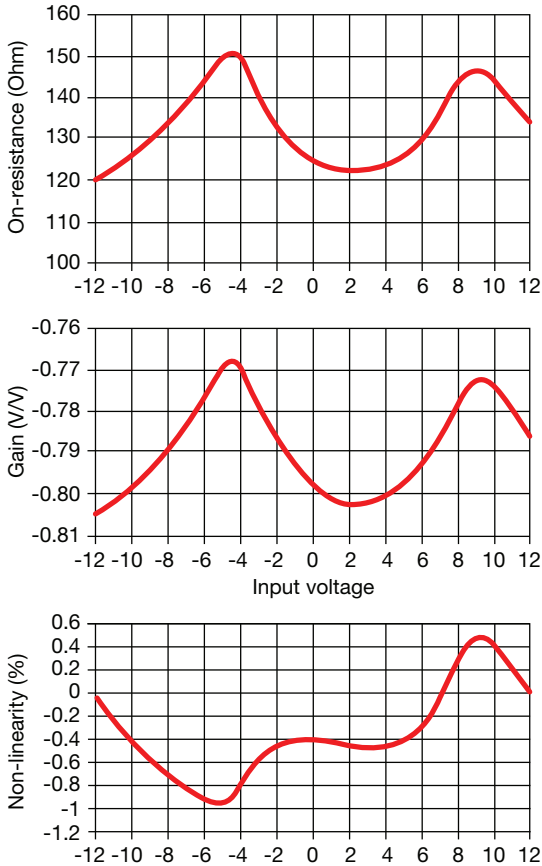
- C_{OFF} = parasitic capacitance when the switch is OFF
 $C_{OFF} = C_S$ (on source side) or C_D (on drain side) (216)

- C_{ON} = parasitic capacitance when the switch is ON
 $C_{ON} \approx C_S + C_D$ (217)

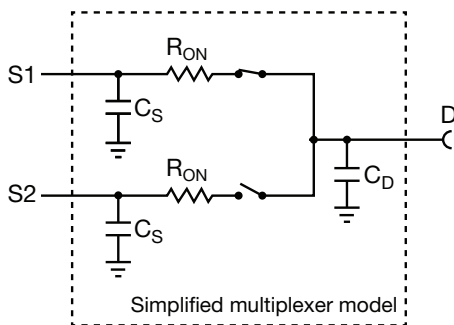

Figure 102: Simplified model for MUX parasitic capacitance calculation

Design tips

Settling time = $t_{TRANSITION} + (R_{ON} \cdot C_D \cdot K)$ (218)

Where

$t_{TRANSITION}$ = MUX channel-to-channel transition time (refer to MUX specification)

R_{ON} = switch ON-resistance between sources and drain

C_D = switch drain parasitic capacitance

K = number of time constants to settle to a N bit resolution ADC, $K = \ln(2^N)$

MUX settling time with C_{LOAD} and R_{LOAD}

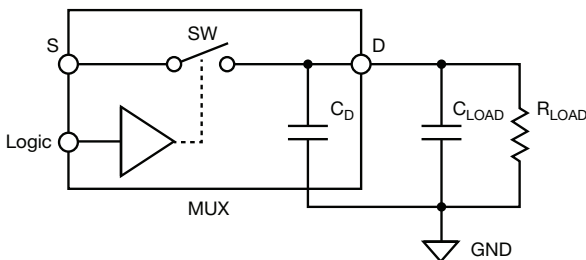

Figure 103: Simplified model for MUX settling time calculation

$$\text{Settling time} = t_{\text{TRANSITION}} + \frac{R_{\text{ON}} \cdot R_{\text{LOAD}}}{R_{\text{ON}} + R_{\text{LOAD}}} (C_{\text{LOAD}} + C_{\text{D}}) \cdot K \quad (219)$$

Where

$t_{\text{TRANSITION}}$ = MUX channel-to-channel transition time (refer to MUX specification)

R_{ON} = switch ON-resistance between sources and drain

R_{LOAD} = resistor connected to MUX output

C_{LOAD} = capacitor connected to MUX output

C_{D} = switch drain parasitic capacitance

K = number of time constants to settle to a N bit resolution ADC, $K = \ln(2^N)$

Example

Determine the settling time of a MUX to 14-bit accuracy.

$R_{\text{ON}}=125\Omega$; $C_{\text{D(OFF)}}=7.5\text{pF}$

$R_{\text{LOAD}}=1\text{k}\Omega$; $C_{\text{LOAD}}=5\text{pF}$

$t_{\text{TRANSITION}}=92\text{ns}$

Answer

$$\text{Settling time} = 92\text{ns} + \frac{125 \cdot 1000}{125 + 1000} \cdot (5\text{pF} + 7.5\text{pF}) \cdot \ln(2^{14}) = 105.5\text{ns}$$

Leakage current

Off leakage current

- $I_{S(OFF)}$ = input leakage current flows through R_{SOURCE}
- $I_{D(OFF)}$ = output leakage current flows through R_L

$$V_{ERROR(OUTPUT)} = R_L \cdot I_{D(OFF)} \quad (220)$$

On leakage current

- $I_{D(ON)} = I_{LEAKAGE}$

$$V_{ERROR(OUTPUT)} = (R_{ON} + R_{SOURCE}) \cdot I_{D(ON)} \quad (221)$$

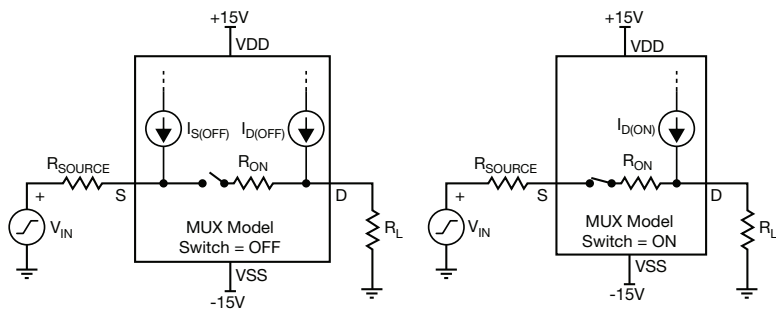

Figure 104: Simplified models for OFF and ON leakage current through a MUX

Example

Determine the Switch = ON error caused by MUX leakage current in an 18-bits system:
Assume R_L is a very high input impedance ($R_L > 100M\Omega$, i.e. an op amp input)

$$R_{SOURCE} = 1M\Omega$$

$$R_{ON} = 100\Omega$$

$$I_{D(ON)} = 100pA$$

$$V_{REF} = 5V$$

Answer

$$V_{LSB} = \frac{5V}{2^{18}} = 19.073\mu V$$

$$V_{ERROR} = I_{D(ON)} \cdot (R_{SOURCE} + R_{ON}) = (100pA) \cdot (1M\Omega + 100\Omega) = 100\mu V$$

$$BIT_{ERROR} = \frac{V_{ERROR}}{V_{LSB}} = \frac{100\mu V}{19.073\mu V} = 5.24 \text{ codes}$$

Charge injection (Q_{INJ})

Voltage change introduced at the output of switch when switch is turned ON or OFF

$$Q_{INJ} = (C_D + C_L) \cdot \Delta V_{OUT} \tag{222}$$

With large load capacitance, effect of C_D can be ignored

$$V_{ERROR} = \Delta V_{OUT} \approx \frac{Q_{INJ}}{C_L} \tag{223}$$

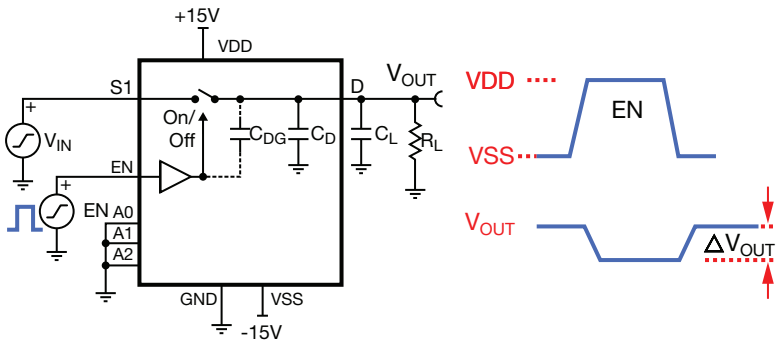

Figure 105: Simplified model for MUX charge injection error

A typical multiplexer charge injection curve vs. input (source) voltage is shown below.

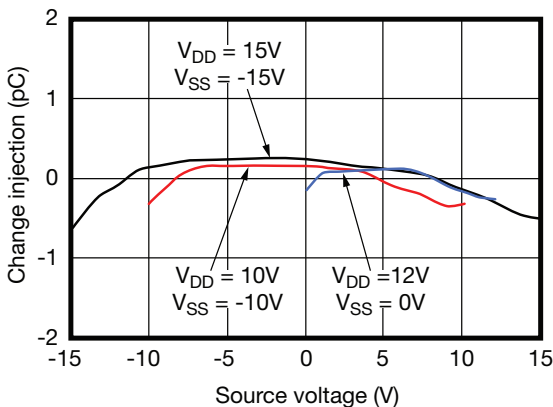

Figure 106: Typical charge injection curve vs. source voltage

Bandwidth (BW)

The frequency at which the output is attenuated by 3 dB from the pass band (DC) response.

$$\frac{V_{OUT}}{V_{IN}} = \left(\frac{R_L}{R_L + R_{ON}} \right) \cdot \left(\frac{1}{\frac{f}{f_{-3dB}} + 1} \right) \tag{224}$$

$$f_{-3dB} = \frac{1}{2\pi \left(\frac{R_L R_{ON}}{R_L + R_{ON}} \right) (C_D + C_L)} \tag{225}$$

If $R_L \gg R_{ON}$:

$$f_{-3dB} = \frac{1}{2 \cdot \pi \cdot R_{ON} \cdot (C_D + C_L)} \tag{226}$$

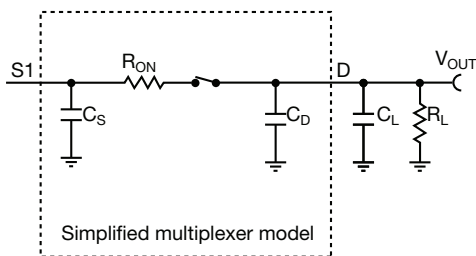

Figure 107: Simplified model for MUX bandwidth calculation

A typical multiplexer bandwidth response vs. frequency is shown below. The device exhibits a -3dB bandwidth of approximately 2GHz.

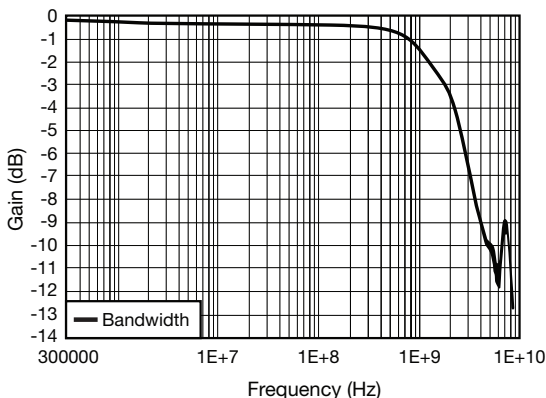

Figure 108: Typical bandwidth response vs. frequency curve

Channel-to-channel crosstalk (X_{TALK})

Crosstalk is defined as the amount of signal read at the input of an OFF channel (V_{OUT}), when V_S is applied to an ON channel.

$$X_{TALK} = 20 \cdot \log\left(\frac{V_{OUT}}{V_S}\right) \tag{227}$$

Where

V_{OUT} = voltage measured at source pin of OFF channel

V_S = voltage applied to source pin of ON channel

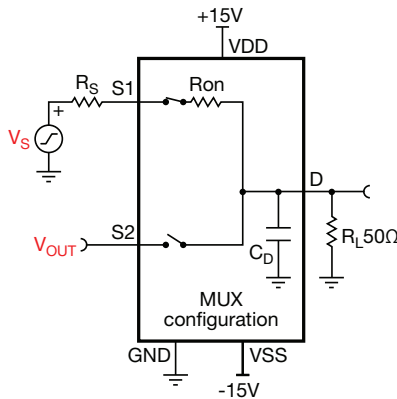

Figure 109: Simplified model for MUX crosstalk calculation

A typical multiplexer crosstalk vs. frequency is shown below for both adjacent and non-adjacent channels.

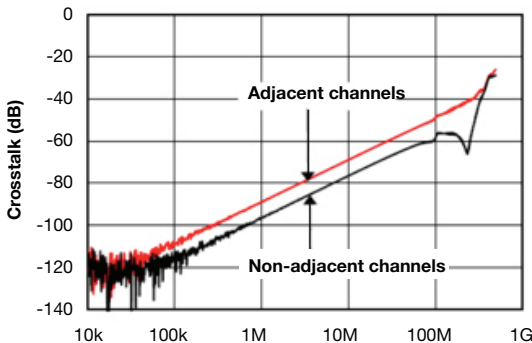

Figure 110: Typical channel-to-channel crosstalk vs. frequency curve

OFF-isolation

Voltage at output pin of a multiplexer when a known signal is applied at the source pin of an off-channel

$$\text{OFF_isolation} = 20 \cdot \log\left(\frac{V_{\text{OUT}}}{V_{\text{IN}}}\right) \tag{228}$$

Where

V_{OUT} = voltage measured at source pin of OFF channel

V_{IN} = voltage applied at source pin of OFF channel

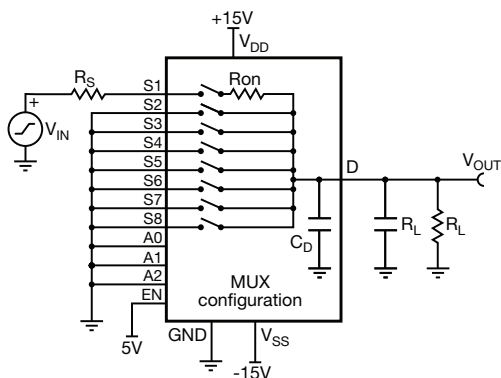

Figure 111: Simplified model for MUX OFF-isolation calculation

A typical multiplexer OFF-isolation vs. frequency is shown below for both adjacent and non-adjacent channels.

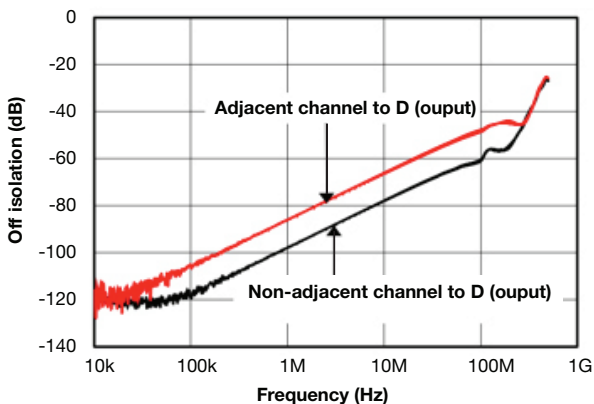

Figure 112: Typical OFF-isolation vs. frequency curve

Total harmonic distortion plus noise (THD+N)

- The ratio of the sum of all harmonic components and total RMS noise to the fundamental signal at the multiplexer output
- Highly dependent on the ON-resistance (R_{ON}) of the multiplexer

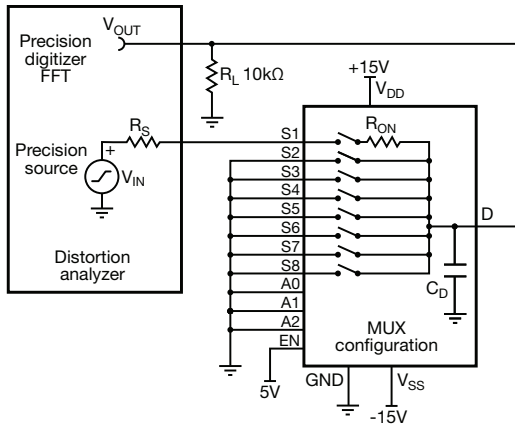

Figure 113: Typical THD+ measurement setup

A typical multiplexer THD+N vs. frequency curve is shown below

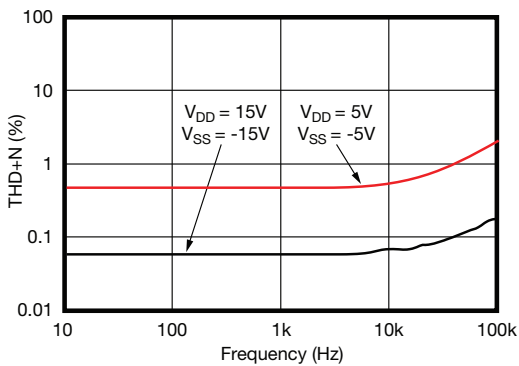

Figure 114: Typical THD+N vs. frequency curve

Design tips

- Use high impedance stage between MUX output and signal conditioning
- Use a multiplexer with lower R_{ON} (at the expense of other design trade-offs)

TI Worldwide Technical Support

TI Support

Thank you for your business. Find the answer to your support need or get in touch with our support center at www.ti.com/support

China: <http://www.ti.com.cn/guidedsupport/cn/docs/supporthome.tsp>

Japan: <http://www.tij.co.jp/guidedsupport/jp/docs/supporthome.tsp>

Technical support forums

Search through millions of technical questions and answers at TI's E2E™ Community (engineer-to-engineer) at e2e.ti.com

China: <http://www.deyisupport.com/>

Japan: <http://e2e.ti.com/group/jp/>

TI Training

From technology fundamentals to advanced implementation, we offer on-demand and live training to help bring your next-generation designs to life. Get started now at training.ti.com

China: <http://www.ti.com.cn/general/cn/docs/gencontent.tsp?contentId=71968>

Japan: <https://training.ti.com/jp>

Important Notice: The products and services of Texas Instruments Incorporated and its subsidiaries described herein are sold subject to TI's standard terms and conditions of sale. Customers are advised to obtain the most current and complete information about TI products and services before placing orders. TI assumes no liability for applications assistance, customer's applications or product designs, software performance, or infringement of patents. The publication of information regarding any other company's products or services does not constitute TI's approval, warranty or endorsement thereof.

A011617

The platform bar and E2E are trademarks of Texas Instruments.
All other trademarks are the property of their respective owners.

$\cos x = \frac{e^{ix} + e^{-ix}}{2}$ $\operatorname{sh} x = \frac{e^x - e^{-x}}{2}$ $\cos \theta = \frac{e^{i\theta} + e^{-i\theta}}{2}$ $\operatorname{tg} x = \frac{e^x - e^{-x}}{e^x + e^{-x}}$

$z = a + bi$ $\bar{z} = a - bi$ $w = c + di$

$1) \bar{z} + \bar{w} = \overline{z+w}$
 $2) \bar{z} \cdot \bar{w} = \overline{z \cdot w}$
 $3) z + \bar{z} = 2\operatorname{Re}(z)$

$v = (a-c, b-d)$ $\operatorname{sh} x = \frac{e^x - e^{-x}}{2}$

$1) \bar{z} + \bar{w} = \overline{z+w}$
 $2) \bar{z} \cdot \bar{w} = \overline{z \cdot w}$
 $3) z + \bar{z} = 2\operatorname{Re}(z)$

$\operatorname{sh} x = \frac{e^x - e^{-x}}{2}$ $z = a + bi$ $\bar{z} = a - bi$

$4) \frac{z}{\bar{z}} = \frac{z}{\bar{z}}$
 $5) \frac{z}{z} = 1$
 $6) z \bar{z} = |z|^2$ $|z| = \operatorname{Mod} de z$
 $7) Si z es raíz de un Pol. en$

$z = 2k\pi i, k \in \mathbb{Z}$

$\operatorname{sh} x = \frac{e^x - e^{-x}}{2}$ $\operatorname{tg} x = \frac{e^x - e^{-x}}{e^x + e^{-x}}$



IMPORTANT NOTICE AND DISCLAIMER

TI PROVIDES TECHNICAL AND RELIABILITY DATA (INCLUDING DATASHEETS), DESIGN RESOURCES (INCLUDING REFERENCE DESIGNS), APPLICATION OR OTHER DESIGN ADVICE, WEB TOOLS, SAFETY INFORMATION, AND OTHER RESOURCES "AS IS" AND WITH ALL FAULTS, AND DISCLAIMS ALL WARRANTIES, EXPRESS AND IMPLIED, INCLUDING WITHOUT LIMITATION ANY IMPLIED WARRANTIES OF MERCHANTABILITY, FITNESS FOR A PARTICULAR PURPOSE OR NON-INFRINGEMENT OF THIRD PARTY INTELLECTUAL PROPERTY RIGHTS.

These resources are intended for skilled developers designing with TI products. You are solely responsible for (1) selecting the appropriate TI products for your application, (2) designing, validating and testing your application, and (3) ensuring your application meets applicable standards, and any other safety, security, or other requirements. These resources are subject to change without notice. TI grants you permission to use these resources only for development of an application that uses the TI products described in the resource. Other reproduction and display of these resources is prohibited. No license is granted to any other TI intellectual property right or to any third party intellectual property right. TI disclaims responsibility for, and you will fully indemnify TI and its representatives against, any claims, damages, costs, losses, and liabilities arising out of your use of these resources.

TI's products are provided subject to TI's Terms of Sale (www.ti.com/legal/termsofsale.html) or other applicable terms available either on ti.com or provided in conjunction with such TI products. TI's provision of these resources does not expand or otherwise alter TI's applicable warranties or warranty disclaimers for TI products.

Mailing Address: Texas Instruments, Post Office Box 655303, Dallas, Texas 75265
Copyright © 2019, Texas Instruments Incorporated