

OmniWah

Building instructions

V1.2

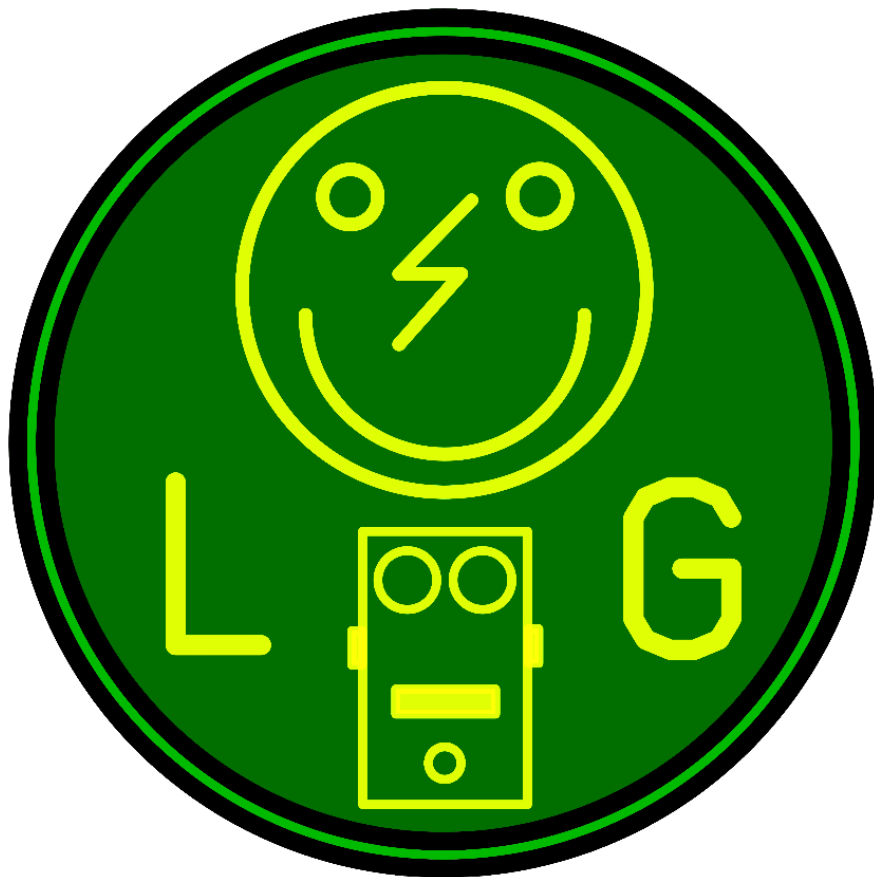

Table of contents

PCB layout	3
Build options.....	4
Vintage Wahs	4
Modern signature Wahs.....	4
Components	5
Inductor	5
Wah Pot.....	5
Resistors and capacitors.....	6
Configuration note	7
Modifications.....	7
Mix and match the configurations	7
Sweep board.....	7
Mechanical Sweeprange mod	8
Outputbuffer	8
R17 Cantrell mod.....	8
Build sequence	9
Off board wiring	10
Potentiometers.....	10
Switch SW1.....	10
Footswitch with external input and output	11
Switch installation	12
Wahpot calibration.....	13
Color coding headers.....	14
Troubleshooting	15
Schematic	16

Read this entire manual thoroughly before you start building the effect! There are some available options and mods and you should choose which one you want to incorporate before starting your build.

Last update: 23-02-2018

PCB layout

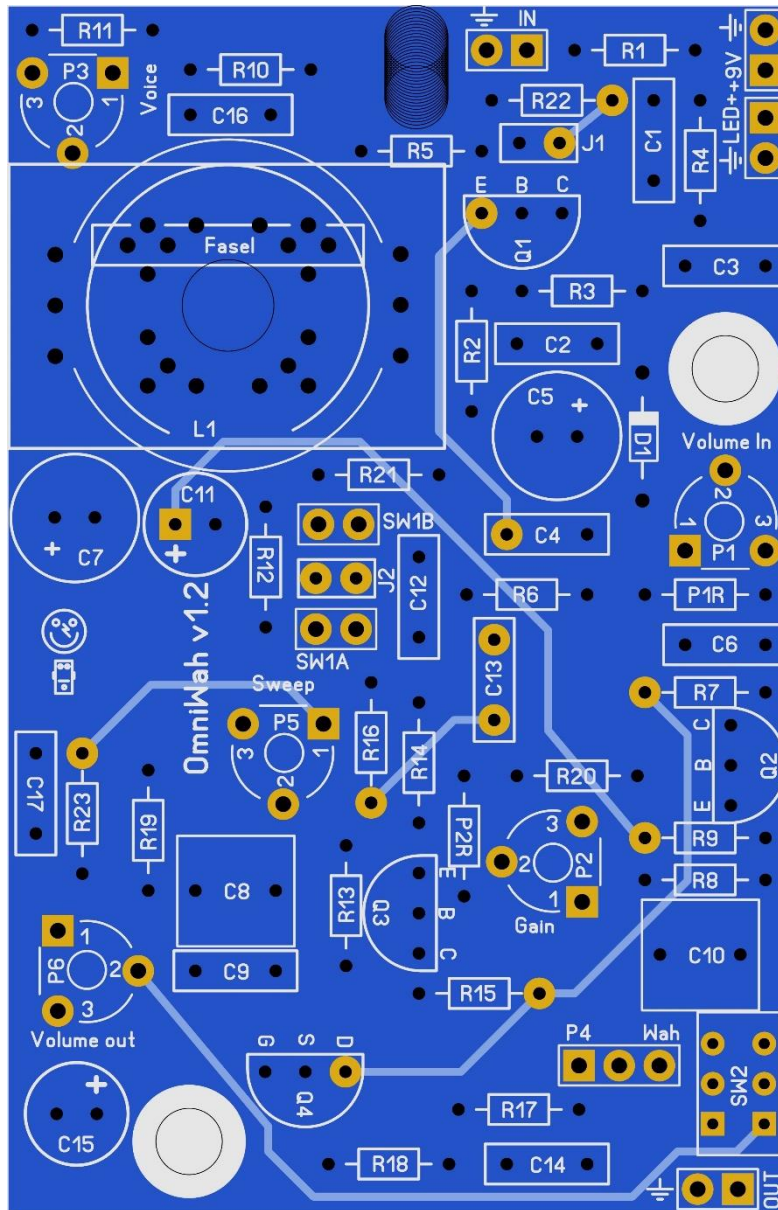

Dimensions: 49,6 mm x 76,5 mm
1.95 inch x 3.01 inch

Build options

This PCB can be used to mimic a wide range of vintage to modern wahs.

Vintage Wahs

- Thomas: Organ CryBaby
- Dallas Arbiter: Wah Face (wah only)
- EH: Electro Harmonix Fuzz Wah (wah only)
- Foxx: Foxx Fuzz Wah Octave (wah only)
- Vox: Grey Wah, v847, Clyde McCoy
- FullTone: Clyde Wah
- Colorsound: Inductor Wah
- Shin Ei: Shinei Wah
- Jen: Italian Jen Wah Clyde McCoy, Mister Crybaby Wah Volume
- Maestro: Boomerang Wah BG-1, BG-2, EG-1
- Fuzzcentral: Axis Wah

Modern signature Wahs

- Dunlop: JH-1 Hendrix Crybaby, ZW-45 Wylde Crybaby, DB-1 Dimebag Crybaby, JC-95 Jerry Cantrell Crybaby, GCB-100 Bass, GCB-95
- BBE: Ben Wah (Axis Wah)
- Rocktron: Tri-Wah
- Custom: Modded Dunlop GCB-95 Crybaby

In the components section you will find the components needed for the different configurations. When it says “jump”, there is no component to be place but instead you’ll need to connect both pads of the component with a jumper wire (eg a spare piece of lead wire you get when cutting a resistor to size). When it says “jump 1-2”, then you’ll need to connect pad 1 to pad 2 of the component with a jumper wire. With “jump 2-3” you’ll need to connect pad 2 to pad 3 of the component with a jumper wire. A dash (“-“) means there is no component to be placed at that spot for that type of wah (no jumper either).

This PCB also fits almost all Wah inductors known to man. Guaranteed and tested are:

Standard Dunlop inductor, Fasal Red/Yellow, Dunlop Stack of Dimes, Eleca Halo (no cutting needed!), ME-6 Tonality, Banzai ProTone, Vintage Dunlop inductor

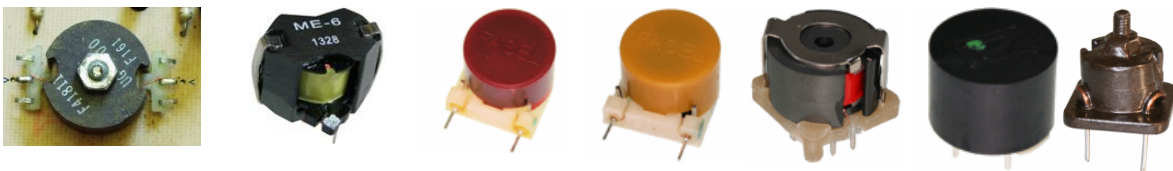

If your inductor has the same pin distance as one of the above then it will fit!

Components

Since the OmniWah can be used to build so many different types of wahs, I've split off the components section into a separate document with all possible configurations.

My advice: Capacitors with values < **1nF** should be **MLCC**, values of **1nF – 1µF** should be **SMF/MKT/MKS** and all values > **1µF** are **Electrolytic**.

Then there is always the magic question: “**Will it really sound like a <your favorite wah brand and series here>?**”. Well, that depends on the quality of the parts you are using. I will not go into a rant about parts (vintage or not) but I will give you my personal view based on building all the configurations and comparing some of them to the original. I also incorporated some feedback I got from customers (special thanks to Ulrich Zmaila). I am always trying to improve my PCBs and instructions, so please feel free to send me feedback!

Inductor

I think this is the most important part to invest in. You can go 2 ways on this. First, you could buy the major brand ones from eg. Dunlop™ or Vox™, but changes are you will not get to the tonal characteristics of your configuration (unless it is a modern Dunlop™ or Vox™ you want ☺). Next, you can buy a real vintage one. You will have a very hard time finding a genuine vintage inductor so the best way to go here is to buy them from people who custom wind them or the non-major brands. This will probably cost you more, but these people often made it their lifework to master this art. Reported and tested good prefab inductors are Eleca Halo and ME-6.

Wah Pot

Also very important. A well enclosed pot will last longer and the type of taper will influence the sweep characteristics. But do not be fooled by sellers who charge you an arm and a leg for a single pot. Experiment and find out yourself! Some tips based on feedback I got:

- **ProPot Deluxe 100k**
Nice even taper, zero Ohm curve on both sides of the resistive strip. It can therefore be perfectly adjusted.
- **Chase ToneTru Talk 100K**
Also nice taper, more pronounced due to has steeper curve (ICAR recreation), closed housing, long lasting
- **Dunlop Hot Potz II**
Even wah taper, long-lasting, plastic resistive strip

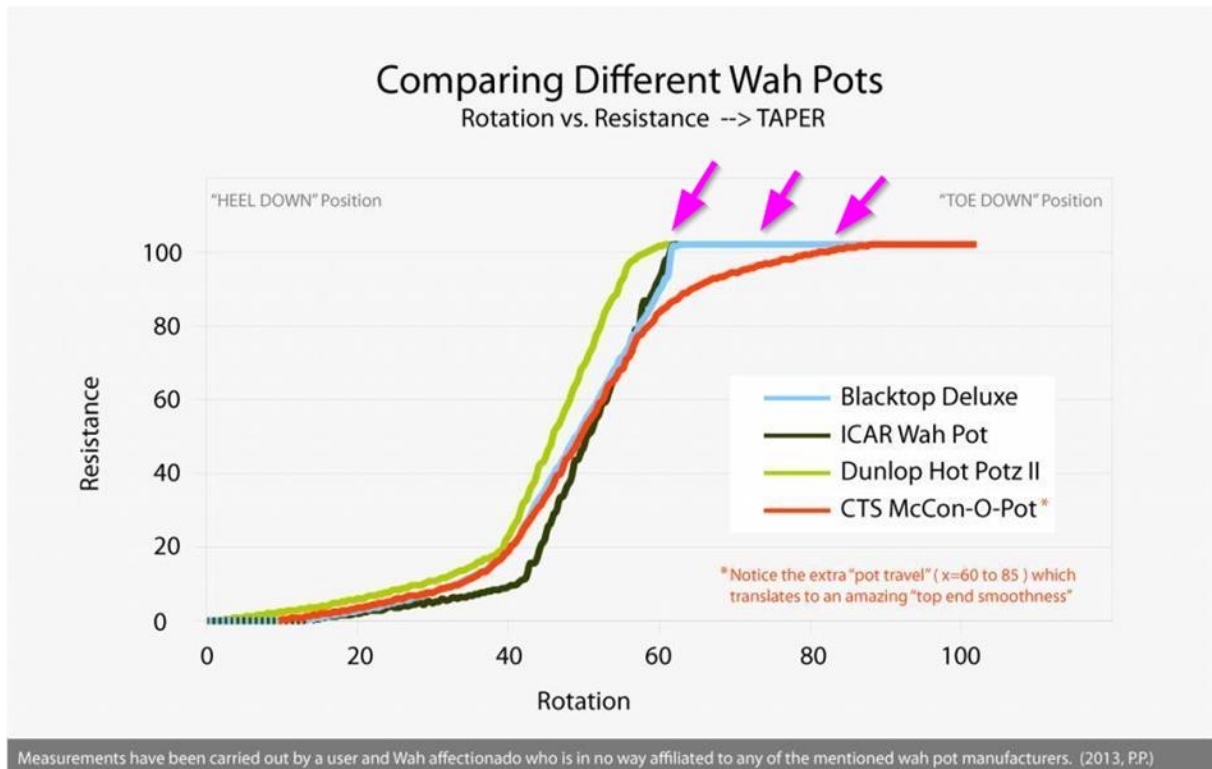

(source: Ebay/Phillip Perkmann)

Resistors and capacitors

Ok, this is going to get me some hate mail. I found no (real) tonal difference using vintage carbon composition resistors or modern metal film resistors. I am NOT a certified electrical engineer so this is based on simply experimenting. Ditto goes for the capacitors. I used mostly WIMA™, SMF and electrolytic capacitors from Panasonic™ and they sound great everywhere. I know that there is a lot of discussion about this on the internet so feel free to totally disagree with me.

None the less the value and tolerance of these components influence the sound greatly. Components have a spread in their values. Every part is sold with these values inside a certain tolerance. Carbon Composite are +/- 5% while metal film mostly are +/- 1%. Capacitors are even worse. Generally the tolerance is about +/- 10% but can also be +/- 5% or even +/- 20%. It depends. This is (only) one of the reasons that no 2 effects of the same type really sound the same. To conclude: sound is more influenced by the tolerance (and change of that over the years) of the components than the brand.

Recreating an effect should also mean that the exact value of the components should be measured and not just their advertised value. An old 20% 4.7 μ F will range between 3.76 μ F and 5.64 μ F. This can and will have a lot of influence in a RC filter!

Lastly, there is also the influence of temperature. Every component will measure different under different temperatures. So, at -20°C an effect might sound different than at +40°C. Do not forget that no capacitor is “perfect/ideal” and actually also has resistance (like ESR) that is temperature sensitive. Electrolytic capacitors are most susceptible to this while non electrolytic capacitors can be treated as ideal components.

Configuration note

P1-P3, **P5** and **P6** are arranged as onboard trimpots on the PCB. This is done because most of them are set and forget. However, you could choose to make them external by wiring a chassis pot to them. For this we added the pinout next to the trimpot pads so you know what pad to connect to which pin on the pot. See the off board wiring section for the pin numbers on the pot.

Note that **P1R** and **P2R** are just a fixed value resistor instead of **P1** and **P2**. See the configuration sheet when to use which.

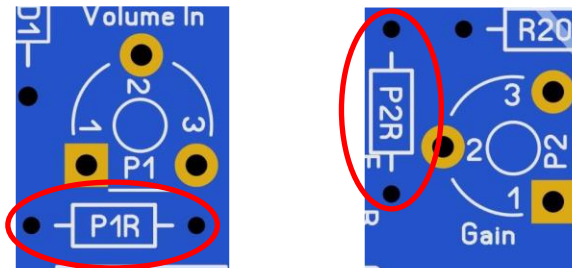

Modifications

Mix and match the configurations

You could mix a few options of different versions to get your own custom effect. I think it would be a good idea to add **R1** (pull down resistor) and **P2** (Gain) to all types. This way you can reduce the pop when switching on the effect and add a gain control that influence the tone of the Wah.

Also consider to experiment with different types of transistors. The described transistors can be replaced with any **300-400 Hfe NPN transistor**.

Sweep board

A nice added feature can be to add a sweep board to replace **C13**. You can use a rotary switch for the for example a 2P5T so you can switch between 5 different values. The example below is just for reference. You can always use different values than mentioned in the picture.

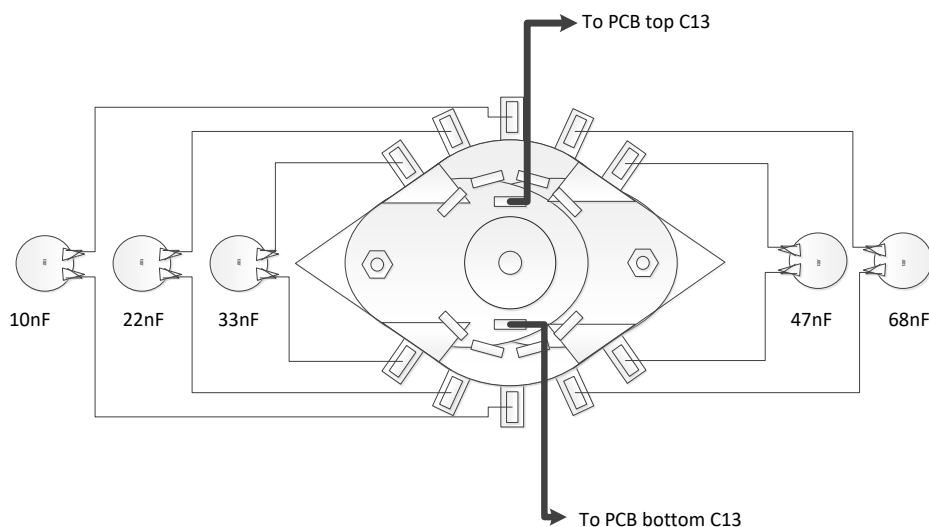

Mechanical Sweeprange mod

If you are using an old crybaby shell, then you might want to remove the rubber underneath the heel of the wah plate. Also you might want to cut about half of the front 2 rubbers off. This way the sweeprange of the wah will increase dramatically. But be careful not to remove too much. Maybe cut in stages and test.



Outputbuffer

Wahpedals do not play nice with a fuzz after them (in series) and will not really “wah”. Although a lot of people like this, it can be prevented by implementing an output buffer. This build includes such an optional output buffer. It is not specific to any build and can be used with any configuration. If you want to incorporate the buffer, you will need to solder **C14**, **C15**, **P6**, **Q4**, **R18**, **R19** and **SW2**.

If you are not planning of implementing the buffer then you should leave out the parts and switch but short **pad 2** and **pad 5** on the PCB (also noted in the configuration sheet) else you will get NO SOUND!

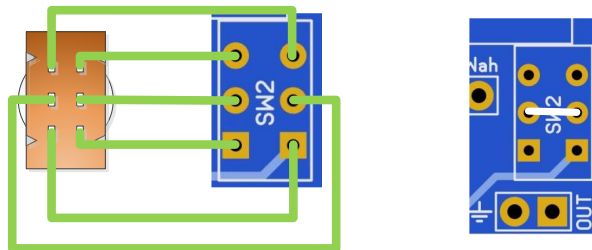

R17 Cantrell mod

R17 is an optional mod so you can have the Wah pot leave a minimal resistance to ground, also called the Jerry Cantrell mod . This mod will influence the beginning and the endpoint of the sweep, to favor either the heel or toe position and thus cut some treble from the sound. It is not used often as it only influences the sound very subtle and it can be somewhere between *0R* and *5k*. Experiment at will or place a trimpot (B5k). By default you should just jump **R17**.

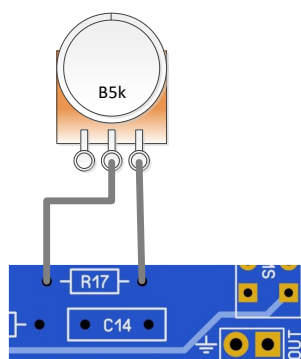

Build sequence

Soldering this board can be very complicated for some people since the solder pads are very close together. Use a magnifying glass to make the job easier. The trick to soldering a PCB is to work from small to big components. My building sequence suggestions in this section are based on the parts I used myself. Sometimes some components are smaller (or bigger) so always use your own common sense and change the order accordingly. Usually capacitors can differ a lot in size depending on their rating and value.

Note: Do not blow on your solder in an attempt to cool it down. That can result in a bad join that might corrode!

Start by soldering the jumpers where needed. Next, solder the resistors and diode (if needed).

If you want to experiment with other transistors then you could socket them instead of soldering them to the board. You'll need a some 20 SIL sockets, break off the sockets and solder them to the board. Now is the time to solder these sockets on the PCB. Place the transistors when you are finished with all soldering and off board wiring!

Note: Orientation of the transistors vary for each different type you use. For this reason I marked the pinout on the board for your convenience. I also added a graphic of the flat and rounded side of the transistor. This is based on the vintage transistors. Eg. a MPSA needs to be rotated 180 degrees! Always consult the datasheet of the transistor and orient accordingly. If you need to cross 2 legs of a transistor, you can use shrink wrap around the legs so they do not short each other.

Now continue by soldering the small capacitors (MLCC) then the small SMF, trim pots and then the Electrolytic capacitors. Finish with soldering the inductor. Note the dotted line on the PCB. It indicates separation of both sides of the inductor. All Wah inductors have only 2 active sides even though there might be more than 2 legs. Wires indicate which legs are connected. See to it that you never have all active legs to one side of the dotted line, but that there is always 1 active leg on 1 side and 1 leg on the other side of the dotted line. Inductors do not have a specific orientation so do not worry about that!

I suggest you now drill the holes in your enclosure (maybe a spare old crybaby shell) so you can use it during the off board wiring. Try to keep wires as short as possible.

Note: Really take some time to determine where to place the pots, switches, jacks and PCB in the enclosure before you start drilling (if any drilling is needed at all). Measure twice, drill once.

You are almost ready to rock, well... not really. The difficult part starts now. Besides the components mentioned in the components table, you will need:

- **1 x 3PDT footswitch** (9 pins)
- **9v battery clip** (optional).
- **22 gage stranded hook-up wire.**
- **A LED holder.** This enables you to mount the LED in the enclosure.
- **Wah enclosure** (new or used). This is actually also optional. You can build this board into a 1590BB and make it a fully customizable fixed/cocked wah. For this there are 4 mounting holes added to the PCB for the standoffs.

Off board wiring

The version 2 of the OmniWah has been designed to be used in a standard Crybaby enclosure with either onboard soldered jacks or separate jacks (like the neutrik/rean type of input jacks). There are also 4 holes added for PCB stands in case you want to use a custom enclosure (1590BB).

Potentiometers

In the pictures below you see the correct pin numbering of the pots (Alpha 16mm style and/or onboard 6mm).

Solder the wires accordingly and it is always a good idea to twist the wires together to create a sort of extra shielding against external noise.

You can break off the pin I marked with the yellow circle with a small pair of pliers.



P1 Volume

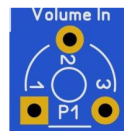

P4 Wah

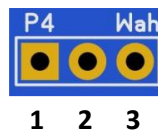

P2 Gain



P5 Sweep



P3 Voice



P6 Volume Out



Switch SW1

When building the Maestro BG-2 configuration you will only need to wire **SW1A**

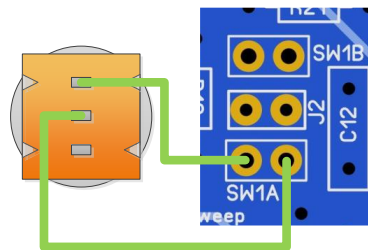

When building the Jen Mr Crybaby wah Volume you will need to wire **SW1A** and **SW1B** with a DPDT switch. If you short **SW1A** (**SW1B**=open) you get the WAH and if you short **SW1B** (**SW1A**=open) you get the volume pedal.

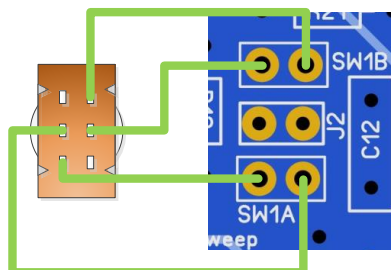



Footswitch with external input and output

Input Jack

Output Jack

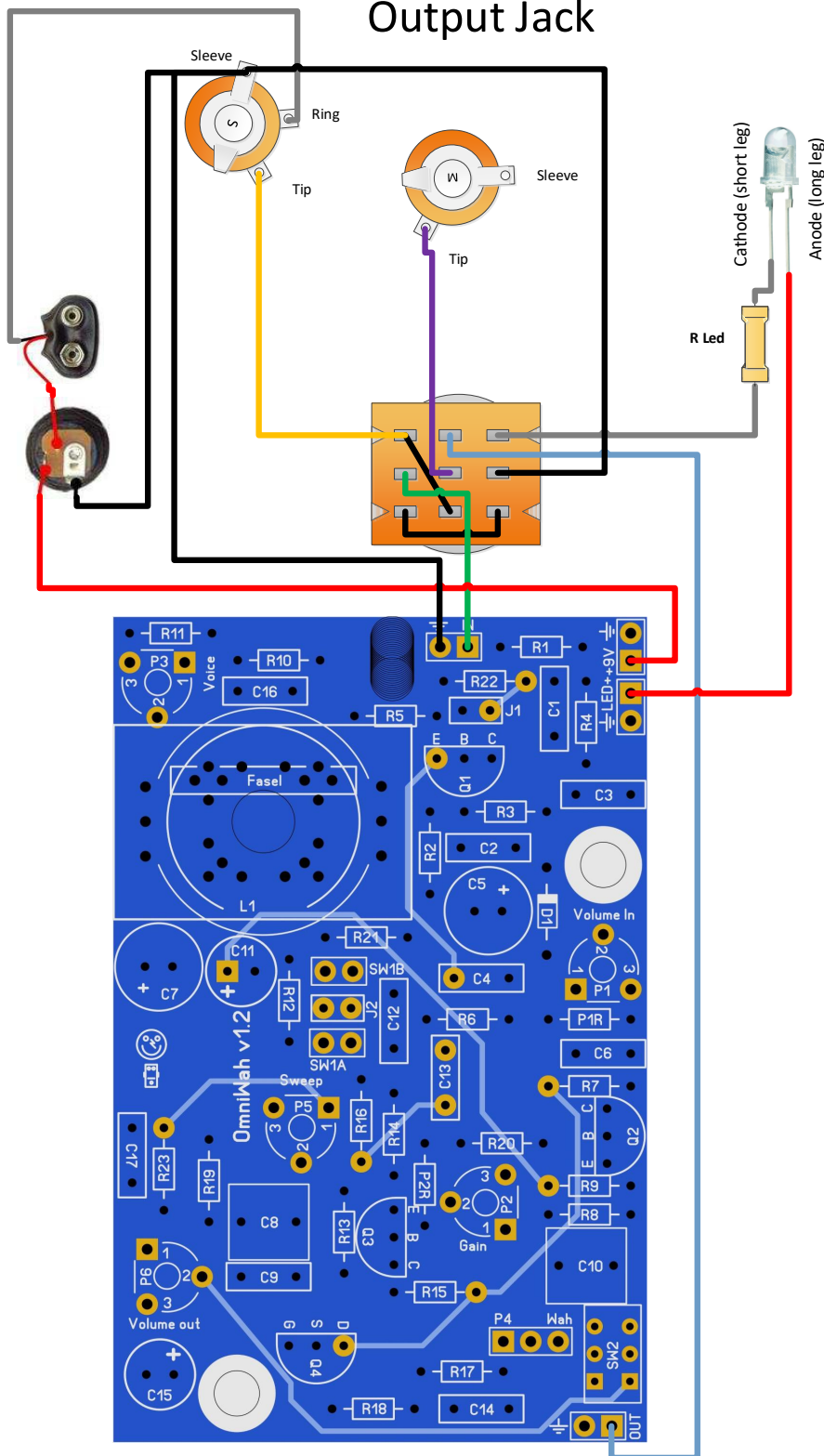

The sleeve on the output jack is not connected on purpose. Make sure the output jack is in good electronic contact with the enclosure else you can try and connect the sleeves of the input and output together. If you test the unit outside of an enclosure you need to connect the output sleeve to ground!

It is now time to place your transistors in the sockets if needed. Connect everything, build it in your enclosure and enjoy your effect!

R led is a **4k7** resistors. You can change this value depending on the type of LED you use but 4k7 is safe enough for almost all LEDs @ 9V.

Switch installation

I usually put switches to the side of the crybaby enclosure by drilling a hole, until Ulrich pointed me out that you could use a short shaft switch just underneath the rocker of your Wah. This way you will prevent breaking off the switch when you accidentally slip off or miss. Take a look at the pictures below and you'll notice it will fit both SPDT as well as DPDT:

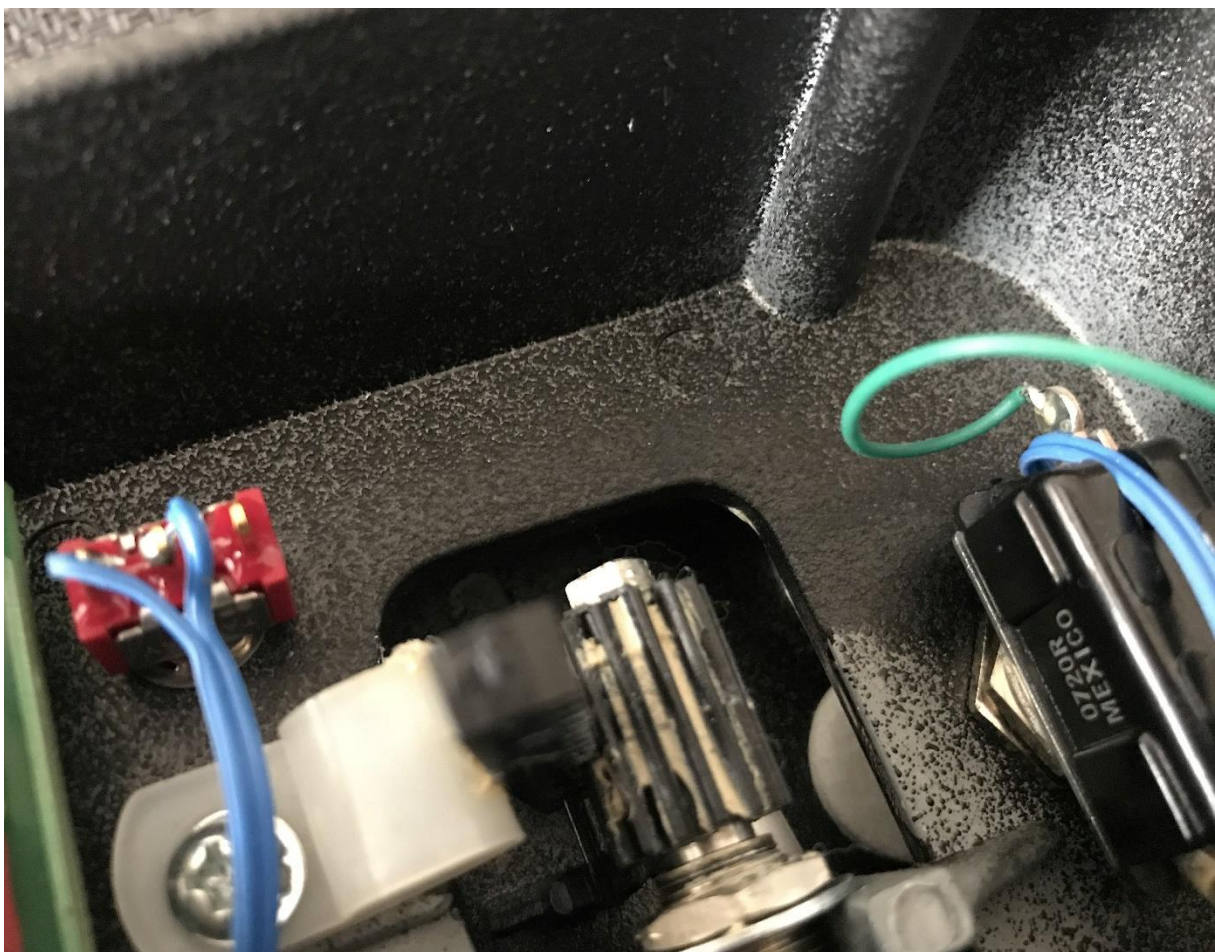

Wahpot calibration

If you feel that your wah is not changing over the full sweep, then you will need to calibrate your wahpot. You can do this by loosening the tension clutch (the white plastic thingy pushing against the rack gear) until you can push it aside enabling you to pull back the rack gear from the wahpot. Do not totally unscrew it!



Connect your wah to your guitar and amp (and power if needed). Push the rack gear against to the teeth of the wah pot ensuring the gears fall in to place without using force, and rock the wah to find out at which end (heel or toe) there is too little change in the wah sound. Once you find it, push back the rack gear and just slightly adjust the wah gear by turning the wah pot. It is important that you try to do this just 1 tooth at a time, else you will overshoot the sweet spot before you know it! Also be careful to not overturn the wahpot in either of the extreme directions of the rack gear. This could cause the gears slip and break after a while as the rocker has more motion than the gears and teeth will allow!

This is how I start. Let's say there is too little action in the toe position. I start by pushing the rocker in the most extreme toe position, clicking the footswitch. I pull the rack gear back, turn the wahpot in the most extreme toe position and turn it back 2 teeth on the wahpot. I push back the rack gear to the wahpot and test it again. If there is still not enough action in the toe position I repeat this and turn the wahpot 1 tooth further. At this point you should always check that in the heel position you still have enough gears left so it does not slip in the heel position. Repeat as many times as possible. Do not forget to refasten the tension clutch once you are done.

If you still do not get the desired sweep then it is time to look at a different taper wahpot!

Color coding headers

Dunlop Crybaby Pre 1990

- Orange : DC Jack +
- Black : DC Jack Ground
- Brown : Tip Input Jack (To PCB In)
- Green : Switch In (shorts with Brown)
- Yellow : Wah Pot lug 2
- Blue : Wah Pot lug 3
- White : Sleeve Input Jack (Ground)
- Black : Battery -
- Purple : Ring Input Jack



Dunlop Crybaby Post 1990 (PCB mounted jacks)

- Black : Battery -
- Red : Battery +
- Black : Ground
- Green : Switch In (To PCB Jack In)
- Yellow : Wah Pot lug 2
- Blue : Wah Pot lug 3
- Purple : Switch out (to Tip Output Jack)



Vox

- Brown : Tip Input Jack (To PCB In)
- Green : Switch In (shorts with Brown)
- Yellow : Wah Pot lug 2
- Blue : Wah Pot lug 3
- White : Ring Input Jack
- Black : Battery -
- Red : Battery +
- Purple : Sleeve Output Jack (Ground)



Troubleshooting

All PCB's have been 100% factory e-tested and out of every batch I receive I build an effect to double check, so there should not be a connection problem on the PCB itself.

The board is not working (at all), what now?

- Check if your 9V is plugged in correctly (and/or soldered correctly on the board). Pay special attention to the polarity.
- Check that you oriented the capacitors, IC's ,transistors and diodes the right way. SMF, MKT and ceramic capacitors as well as resistors do not need to be oriented. A likely sign of incorrect capacitors and/or orientation is when an effect is sputtering, rumbling or "motorboating".
- Check if you used the correct values of the components. For resistors you can look here: <http://www.diyaudioandvideo.com/Electronics/Color/>
- Double and triple check your soldering! A loose or cold solder can be really bad for your board.
- Replace the IC and/or transistors, one might be defective. Before doing that first unplug the 9V and wait for 5 seconds.
- Check that you have good/high grade components. A lot of Chinese sourced parts are fakes (especially high end opamps, audio capacitors, vintage diodes and transistors) so be careful that you source your parts from reliable suppliers.



Schematic

